

Agilent E5070A/E5071A ENA Series RF Network Analyzers

Service Manual

Second Edition

FIRMWARE REVISIONS/SERIAL NUMBERS

This manual applies directly to instruments that have the serial number JP1KJ00111 or above (for E5070A), and JP1K00238 or above (for E5071A). For additional important information about serial numbers, see Appendix A.



Agilent Technologies

Agilent Part No. E5070-90110

March 2003

Printed in Japan

Notices

The information contained in this document is subject to change without notice.

This document contains proprietary information that is protected by copyright. All rights are reserved. No part of this document may be photocopied, reproduced, or translated into another language without the prior written consent of the Agilent Technologies.

Agilent Technologies Japan, Ltd.

Component Test PGU-Kobe

1-3-2, Murotani, Nishi-ku, Kobe, Hyogo, 651-2241 Japan

© Copyright Agilent Technologies Japan, Ltd. 2002, 2003

Portions © Copyright 1996, Microsoft Corporation. All rights reserved.

Manual Printing History

The manual's printing date and part number indicate its current edition. The printing date changes when a new edition is printed. (Minor corrections and updates that are incorporated at reprint do not cause the date to change.) The manual part number changes when extensive technical changes are incorporated.

April 2002	Preliminary
June 2002	First Edition
March 2003	Second Edition

Safety Summary

The following general safety precautions must be observed during all phases of operation, service, and repair of this instrument. Failure to comply with these precautions or with specific WARNINGS elsewhere in this manual may impair the protection provided by the equipment. In addition it violates safety standards of design, manufacture, and intended use of the instrument.

Agilent Technologies assumes no liability for the customer's failure to comply with these requirements.

NOTE E5070A/E5071A comply with INSTALLATION CATEGORY II and POLLUTION DEGREE 2 in IEC61010-1. E5070A/E5071A are INDOOR USE product.

NOTE LEDs in E5070A/E5071A are Class 1 in accordance with IEC60825-1.
CLASS 1 LED PRODUCT







- **Ground The Instrument**
To avoid electric shock hazard, the instrument chassis and cabinet must be connected to a safety earth ground by the supplied power cable with earth blade.
- **DO NOT Operate In An Explosive Atmosphere**
Do not operate the instrument in the presence of flammable gasses or fumes. Operation of any electrical instrument in such an environment constitutes a definite safety hazard.
- **Keep Away From Live Circuits**
Operating personnel must not remove instrument covers. Component replacement and internal adjustments must be made by qualified maintenance personnel. Do not replace components with the power cable connected. Under certain conditions, dangerous voltages may exist even with the power cable removed. To avoid injuries, always disconnect power and discharge circuits before touching them.
- **DO NOT Service Or Adjust Alone**
Do not attempt internal service or adjustment unless another person, capable of rendering first aid and resuscitation, is present.
- **DO NOT Substitute Parts Or Modify Instrument**
Because of the danger of introducing additional hazards, do not install substitute parts or perform unauthorized modifications to the instrument. Return the instrument to a Agilent Technologies Sales and Service Office for service and repair to ensure that safety features are maintained.
- **Dangerous Procedure Warnings**
Warnings, such as the example below, precede potentially dangerous procedures throughout this manual. Instructions contained in the warnings must be followed.

WARNING

Dangerous voltages, capable of causing death, are presenting this instrument. Use extreme caution when handling, testing, and adjusting this instrument.

Safety Symbol

General definitions of safety symbols used on the instrument or in manuals are listed below.

-  Instruction Manual symbol: the product is marked with this symbol when it is necessary for the user to refer to the instrument manual.
-  Alternating current.
-  Direct current.
-  On (Supply).
-  Off (Supply).
-  In position of push-button switch.
-  Out position of push-button switch.



Frame (or chassis) terminal. A connection to the frame (chassis) of the equipment which normally include all exposed metal structure.



Stand-by.

WARNING

This warning sign denotes a hazard. It calls attention to a procedure, practice, condition or the like, which, if not correctly performed or adhered to, could result in injury or death to personnel.

CAUTION

This Caution sign denotes a hazard. It calls attention to a procedure, practice, condition or the like, which, if not correctly performed or adhered to, could result in damage to or destruction of part or all of the product.

NOTE

Note denotes important information. It calls attention to a procedure, practice, condition or the like, which is essential to highlight.

Certification

Agilent Technologies certifies that this product met its published specifications at the time of shipment from the factory. Agilent Technologies further certifies that its calibration measurements are traceable to the United States National Institute of Standards and Technology, to the extent allowed by the Institution's calibration facility, or to the calibration facilities of other International Standards Organization members.

Warranty

This Agilent Technologies instrument product is warranted against defects in material and workmanship for a period of three years from the date of shipment, except that in the case of certain components listed in this manual, the warranty shall be for the specified period. During the warranty period, Agilent Technologies Company will, at its option, either repair or replace products that prove to be defective.

For warranty service or repair, this product must be returned to a service facility designated by Agilent Technologies. Buyer shall prepay shipping charges to Agilent Technologies and Agilent Technologies shall pay shipping charges to return the product to Buyer. However, Buyer shall pay all shipping charges, duties, and taxes for products returned to Agilent Technologies from another country.

Agilent Technologies warrants that its software and firmware designated by Agilent Technologies for use with an instrument will execute its programming instruction when property installed on that instrument. Agilent Technologies does not warrant that the operation of the instrument, or software, or firmware will be uninterrupted or error free.

Limitation of Warranty

The foregoing warranty shall not apply to defects resulting from improper or inadequate maintenance by Buyer, Buyer-supplied software or interfacing, unauthorized modification or misuse, operation outside the environmental specifications for the product, or improper site preparation or maintenance.

IMPORTANT

No other warranty is expressed or implied. Agilent Technologies specifically disclaims the implied warranties of merchantability and fitness for a particular purpose.

Exclusive Remedies

The remedies provided herein are buyer's sole and exclusive remedies. Agilent Technologies shall not be liable for any direct, indirect, special, incidental, or consequential damages, whether based on contract, tort, or any other legal theory.

Assistance

Product maintenance agreements and other customer assistance agreements are available for Agilent Technologies products.

For any assistance, contact your nearest Agilent Technologies Sales and Service Office. Addresses are provided at the back of this manual.

Typeface Conventions

Sample (bold)	Boldface type is used when a term is defined or emphasised.
<i>Sample (Italic)</i>	Italic type is used for emphasis.
Sample key	Indicates a hardkey (key on the front panel or external keyboard) labeled "Sample." "key" may be omitted.
Sample menu/button/box	Indicates a menu/button/box on the screen labeled "Sample" which can be selected/executed by clicking. "menu," "button," or "box" may be omitted.
Sample block/toolbar	Indicates a block (group of hardkeys) or a toolbar

Sample 1 - Sample 2 - Sample 3

(setup toolbar) labeled “Sample.”

Indicates a sequential operation of **Sample 1**, **Sample 2**, and **Sample 3** (menu, button, or box).
“-” may be omitted.

1. General Information

Precautions	16
Software Installed	16
Organization of Service Manual	17
Instrument Covered by This Manual	19
Required Equipment	20

2. Performance Tests

Introduction	24
Test Equipment Required	25
1. FREQUENCY ACCURACY TEST	26
Description	26
Specification	26
Test equipment	26
Procedure	26
2. RF OUTPUT LEVEL ACCURACY AND FLATNESS TEST	29
Description	29
Specification	29
Test equipment	29
Procedure	29
3. RF OUTPUT LEVEL LINEARITY TEST	32
Description	32
Specification	32
Test equipment	32
Procedure	32
4. TRACE NOISE CW TEST	35
Description	35
Specification	35
Test equipment	35
Procedure	35
5. CROSSTALK TEST	41
Description	41
Specification	41
Test equipment	41
Procedure	41
Crosstalk test program	48
6. SYSTEM DYNAMIC RANGE TEST	51
Description	51
Specification	51
Test equipment	51
Procedure	52
System Dynamic Range test program	62
7. DYNAMIC ACCURACY TEST	66
Description	66
Test Equipment	66
Procedure	67
8. UNCORRECTED SYSTEM PERFORMANCE TEST	82
Description	82
Specification	82

Contents

Test Equipment	82
Procedure	82
E5070A/E5071A Performance Test Calculation Sheet	99
Introduction	99
2. RF Output Level Accuracy and Flatness Test	99
3. RF Output Level Linearity Test	100
4. Trace Noise CW Test	102
7. Dynamic Accuracy Test	103
E5070A Performance Test Record	106
Frequency Accuracy Test	106
RF Output Level Accuracy and Flatness Test	106
RF Output Level Linearity Test (@ Port1)	107
Trace Noise CW Test (Magnitude)	108
Crosstalk Test	110
System Dynamic Range Test	110
Dynamic Accuracy Test	112
Uncorrected System Performance Test	115
E5071A Performance Test Record	117
Frequency Accuracy Test	117
RF Output Level Accuracy and Flatness Test	117
RF Output Level Linearity Test (@ Port1)	118
Trace Noise CW Test (Magnitude)	120
Crosstalk Test	123
System Dynamic Range Test	124
Dynamic Accuracy Test	126
Uncorrected System Performance Test	130
3. Adjustment	
Safety Considerations	134
Warm-up for Adjustment	134
Required Equipment	134
Required Adjustment after Replacing Assembly	135
Writing ID	135
Frequency Reference Adjustment	135
Oven Reference Adjustment	136
IF Range Gain/Phase Adjustment	136
Source Power Adjustment	136
Test Ports Characteristics Adjustment	137
4. Troubleshooting	
Introduction	140
How to exit from the E5070A/E5071A Measurement View	141
To Troubleshoot the Instrument	142
Primary Trouble Isolation	142
No Display troubleshooting	144
Booting Process Troubleshooting	147
Troubleshooting Using Internal Test	156
Power On Self Test	156

PLL unlock	156
External reference signal phase unlock (Opt. 1E5)	156
To Execute the Internal Test	157
Internal Test Failure Troubleshooting	160
Function Specific Troubleshooting	165
To Check the Device Driver	166
To Check the Front Panel	167
To Check the Touch Panel (Option 016 only)	168
To Check the LCD	169
To Check the External Keyboard	169
To Check the Mouse	169
To Check the FDD	170
To Check the Video output	170
To Check the External Trigger Input	170
To Check the LAN	171
To Check the Printer Parallel Port	175
To Check the GPIB	176
Troubleshooting Using External Test	177
Contents of the external test	177
Test equipment required for external test	178
To Execute the External Test rev. A.01.01 (or earlier)	178
[2] Tch IF Ranging tests	182
To Execute the External Test rev. A.03.00	194
External Test Failure Troubleshooting	208
Performance test failure troubleshooting	214
Recommended adjustment for performance test failure	214
Performance test failure troubleshooting	214
To configure the A20 Digital Motherboard and BIOS	216
To Identify the Motherboard Installed	216
Configure the Motherboard	216
Testing DRAM on the Motherboard	218
To Confirm or Set the BIOS Options	218

5. Replaceable Parts

Ordering Information	234
Direct Mail Order System	234
Exchange Assemblies	234
Replaceable Parts List	235
Power Cables and Plug Configurations	235
Top View (Major Assemblies)	236
Top View (Cables)	238
Top View (Miscellaneous Parts)	240
Top View (Under Power Supply)	242
Top View (Motherboard and Other Parts)	244
Front View (Analog)	246
Front View (Miscellaneous Parts)	247
Front View (Semirigid Cables) (Opt. 213)	248
Front View (Semirigid Cables) (Opt. 214)	249
Front View (Semirigid Cables) (Opt. 313)	250

Front View (Semirigid Cables) (Opt. 314)	252
Front View (Semirigid Cables) (Opt. 413)	254
Front View (Semirigid Cables) (Opt. 414)	256
Front Panel	258
Rear View	260
Side View	261
Cover Assembly	262
A28 FDD Assembly	263
A27 Mass Storage Disk Drive Assembly	264
A8 RF Switch Assembly.	266
A7 Source Step Attenuator Assembly (Opt. 214, 314, 414).	267
A2 Receiver Board Assembly.	268
Receiver Module Assembly (Opt. 31x, 41x)	269
Analog Mother Board Assembly	270
Chassis Assembly	271
Keyboard Assembly	272
LCD and Inverter Assembly.	273
Standby Switch Assembly	274
Cover Assembly	275
Cover Assembly	276
Label on Rear Face	277
Other Parts	278

6. Replacement Procedure

Replacing an Assembly	280
Required Tools	281
Outer Cover Removal.	282
Tools Required	282
Procedure	282
Front Panel Removal	284
Tools required	284
Procedure	284
A27 Mass Storage Disk Drive Replacement	285
Tools Required	285
Removal Procedure.	285
Replacement Procedure	285
Restore Backup Files onto the New Mass Storage Disk Drive	285
Calibration of the Touch Screen	286
A28 FDD (Floppy Disk Drive) Removal.	288
Tools Required	288
Procedure	288
A23 Handler I/O Board Removal.	289
Tools Required	289
Procedure	289
A50 ATX Power Supply Assembly Removal	290
Tools Required	290
Procedure	290
CPU Removal.	292
Tools Required	292

Procedure	292
DIMM Module Removal	294
Tools Required	294
Procedure	294
A20 Digital Motherboard Replacement	295
Tools Required	295
Removal Procedure	295
Replacement Procedure	296
A1 Source Board Removal	297
Tools Required	297
Removal Procedure	297
A2 Receiver Board Removal	299
Tools Required	299
Removal Procedure	299
Module Disassemble Procedure	300
Board Disassemble Procedure	301
B1 Fan & A6 Switch Control Board Removal	302
Tools Required	302
Procedure	302
B1 Fan Removal	303
Tools Required	303
Procedure	303
A5 Crystal Oven Board (Opt.1E5) Removal	304
Tools Required	304
Procedure	304
A8 RF Switch Replacement	305
Tools Required	305
A8 RF Switch (source board side)	305
A8 RF Switch (receiver board side)	306
A7 Source Step Attenuator Removal (Option 214, 314 and 414)	308
Tools Required	308
Procedure	308
A10 Analog Motherboard Removal	310
Tools Required	310
Procedure	310
A21 Analog Interface Board Removal	311
Tools Required	311
Procedure	311
A26 LCD Interface Card Removal	312
Tools Required	312
Procedure	312
A24 GPIB Card Replacement	314
Tools Required	314
Removal Procedure	314
Replacement Procedure	314
A22 Front Panel Keyboard Removal	316
Tools Required	316
Procedure	316
A52 Inverter Board Removal	318

Contents

Tools Required	318
Procedure	318
A51 LCD Display Removal	320
Tools Required	320
Procedure	320
Calibration of the Touch Screen	321
LCD Backlight Removal	322
Tools Required	322
Removal Procedure	322
N Connector Removal	323
Tools Required	323
Removal Procedure	323
7. Post-Repair Procedures	
Post-Repair Procedures	326
A. Manual Changes	
Manual Changes	330
Change 1	331
“Top View (Major Assemblies)” on page 236	331
“Top View (Miscellaneous Parts)” on page 240	333
Rear View	335
Table 6-1 on page 281	336
Outer Cover Removal	337
“A50 ATX Power Supply Assembly Removal” on page 290	339
“A20 Digital Motherboard Replacement” on page 295	340
B. System Recovery	
System Recovery for the E5070A/E5071A	344
Operating Steps	344
C. Firmware Update	
Firmware Update	348
Required Equipment	348
How to make E5070A/E5071A Firmware Installation Disk	348
How to update the E5070A/E5071A firmware	349
D. Computer Virus Check	
Computer Virus Check	354
Required equipment	354
How to check the drive C and D of E5070A/E5071A	354
E. Power Requirement	
Preparation for Power Supply	364
Power Requirements	364
Power Cable	364
Turning the Power ON and OFF	366

Turning the power ON	366
Turning the power OFF	366

F. Messages

Error Messages	369
A	369
B	369
C	369
D	370
E	370
F	371
G	372
H	372
I	372
L	373
M	373
N	373
O	374
P	374
Q	375
R	376
S	376
T	377
U	378
V	378
Warning Message	379
Messages indicating the internal status of the equipment	380
Messages indicating measurement failure	380
Messages indicating the results (or current status) of processing	381

1 General Information

The Service Manual is a guide to servicing the E5070A/E5071A ENA Series Network Analyzer. The manual contains information requisite to do performance tests, adjustments, troubleshooting, and repairs.

Precautions

This section describes cautions that must be observed in operating the E5070A/E5071A.

Software Installed

The Windows operating system installed in this machine is customized for more effective operation, and has different functions that are not part of the Windows operating system for ordinary PCs (personal computers).

Therefore, do not attempt to use the system in ways other than those described in this manual or to install Windows-based software (including anti-virus software) for ordinary PCs as doing so may cause malfunctions.

Also note the followings.

- Do not update the Windows operating system installed in this machine to the Windows operating system for ordinary PCs. Doing so will cause malfunctions.
- Do not attempt to update VBA (Visual Basic for Applications) software installed in this machine to its equivalent developed for ordinary PCs. Doing so will cause malfunctions.
- Do not allow any computer virus to infect the system. This machine has no virus check function nor anti-virus software installed.

Agilent Technologies will not be held liable for any failure or damage arising from negligence regarding these prohibitions and warnings.

NOTE

If the pre-installed software is damaged somehow, resulting in errant behavior by the machine, perform a system recovery. For further details of system recovery, refer to Appendix B.

Organization of Service Manual

Tabs are used to divide the major chapter and appendix of this manual. The contents of each chapter and appendix in this manual is as follows;

Chapter 1 , “General Information,”

The Service Manual is a guide to servicing the E5070A/E5071A ENA Series Network Analyzer. The manual contains information requisite to do performance tests, adjustments, troubleshooting, and repairs.

Chapter 2 , “Performance Tests,”

This chapter provides information on how to verify the E5070A/E5071A performance.

Chapter 3 , “Adjustment,”

This chapter provides the adjustment information for the E5070A/E5071A ENA Series Network Analyzer to ensure that the it is within its specifications. The adjustment must be performed Agilent’s qualified service personnel. If you need the adjustment for your E5070A/E5071A, it should be sent to the nearest Agilent Technologies service office.

Chapter 4 , “Troubleshooting,”

This chapter provides procedure to isolate a faulty assembly in the E5070A/E5071A Network Analyzer

Chapter 5 , “Replaceable Parts,”

This chapter contains information for ordering replacement parts for the E5070A/E5071A ENA Series RF Network Analyzers.

Chapter 6 , “Replacement Procedure,”

This chapter provides procedure for removing and replacing the major assemblies in the E5070A/E5071A ENA Series Network Analyzer.

Chapter 7 , “Post-Repair Procedures,”

This chapter lists the procedures required to verify the E5070A/E5071A operation after an assembly is replaced with a new one.

Appendix A , “Manual Changes,”

This appendix contains the information required to adapt this manual to versions or configurations of the E5070A/E5071A manufactured earlier than the current printing date of this manual. The information in this manual applies directly to E5070A/E5071A units with the serial number that is printed on the title page of this manual.

Appendix B , “System Recovery,”

This appendix describes how to recover the operating system (Windows 98) when the operating system has damage.

General Information
Organization of Service Manual

Appendix C , “Firmware Update,”

This appendix describes how to update the E5070A/E5071A firmware. When you want to update the E5070A/E5071A firmware, refer to this appendix.

Appendix D , “Computer Virus Check,”

This appendix describes an example of how to check the system of E5070A/E5071A for computer viruses using computer viruses check software.

Appendix E , “Power Requirement,”

Chapter F , “Messages,”

The E5070A/5071A can display error messages as well as messages that indicate the internal operating status of the equipment. This appendix explains what these messages mean by listing them in alphabetical order.

Instrument Covered by This Manual

Agilent Technologies uses a two-part, ten-character serial number label (See Figure 1-1) attached to the instrument's rear panel. The first five characters are the serial prefix and the last five digits are the suffix.

Figure 1-1

Serial Number Label Example



serial

An instrument manufactured after the printing date of this manual may have serial number prefix that is not listed on the title page. This unlisted serial number prefix indicates the instrument is different from those described in this manual. The manual for this new instrument may be accompanied by a yellow Manual Changes supplement or have a different manual part number. This sheet contains “change information” that explains how to adapt the manual to the newer instrument.

In addition to change information, the supplement may contain information for correcting errors (Errata) in the manual. To keep this manual as current and accurate as possible, Agilent Technologies recommends that you periodically request the latest Manual Changes supplement. The supplement for this manual is identified by this manual's printing data and is available from Agilent Technologies. If the serial prefix or number of an instrument is lower than that on the title page of this manual, see Appendix A, Manual Changes. For information concerning, a serial number prefix that is not listed on the title page or in the Manual change supplement, contact the nearest Agilent Technologies office.

Required Equipment

Table 1-1 lists the recommended equipment for performing maintenance on the E5070A/E5071A.

Table 1-1 Recommended Test Equipment

Equipment	Critical specifications	Recommended Model	Qty.	Use ^{*1}
Frequency Counter	Frequency: 50 MHz to 3 GHz Accuracy: < 2.5 ppm	Agilent 53181A with Opt.010 & 030 ^{*2}	1	P,A
Frequency Standard	Frequency: 10 MHz, Time Base Error: $\leq \pm 1 \times 10^{-10}$ /year	Agilent 5071A	1	A
Power Meter	No Substitute	Agilent E4419A/B or E4418A/B	1	P,A
Power Sensor	No Substitute	Agilent 8482A	1	P,A
Power Sensor	No Substitute	Agilent E4412A	1	P,A
Dynamic Accuracy Test Kit	No substitute	Agilent Z5623A with Opt. H01	1	P
Calibration Kit	No Substitute	Agilent 85032F	1	P,A,T
Short	Type-N(m)	part of Agilent 85032F/54D/33E/50D with Type-N adapter	4	P,T
Load	Type-N(m)	part of Agilent 85032F/54D/33E/50D with Type-N adapter	2	P
Fixed attenuator (6 dB)	50 Ω , N(m)-N(f), VSWR ≤ 1.015	Agilent 8491A w/Opt.006 and H60	1	P,A
Fixed attenuator (10 dB)	50 Ω , N(m)-N(f)	Agilent 8491A/B/C	1	T
Handler I/O Test Kit	No substitute	Agilent p/n E5070-65001	1	T
Cable	BNC(m)-BNC(m) Cable, 61 cm Coaxial cable with Type-N (m) connectors, 61 cm (24 in), 2 ea.	Agilent p/n 8120-1839	1	P,A
		Agilent N6314A (p/n 8120-8862)	1	P,A,T
Adapter	N(m)-BNC(f) Adapter	Agilent p/n 1250-0780	1	P,A
Torque Wrench	Size: 3/4 inch Torque: 136 N-cm	Agilent p/n 8710-1766	1	P,A

Table 1-1 Recommended Test Equipment

Equipment	Critical specifications	Recommended Model	Qty.	Use ^{*1}
Personal Computer with GPIB board	Windows 95, 98, NT4 or 2000, VEE5.0 or 6.0		1	P,A

*1. P: Performance Tests, A: Adjustment, T: Troubleshooting

*2. Opt.050 and Opt.124 can be substituted for Opt.030. In this case, a N(m)-BNC(f) adapter is necessary.

Table 1-2 Alternative Test Equipment

Equipment	Critical specifications	Model	Qty.	Use ^{*1}
Frequency Counter	Frequency: 50 MHz to 3 GHz Accuracy: < 2.5 ppm	53131/2A with Opt.010 and 030 ^{*2}	1	P,A
Power Meter	No Substitute	E4418A/B	1	P
Short	Type-N(m)	11512A	4	P,T
Load	Type-N(m)	909F Opt. 012	4	P

*1. P: Performance Tests, A: Adjustment, T: Troubleshooting

*2. Opt.050 and Opt.124 can be substituted for Opt.030. In this case, a N(m)-BNC(f) adapter is necessary.

General Information
Required Equipment

2 Performance Tests

This chapter provides information on how to verify the E5070A/E5071A performance.

Introduction

This literature provides the performance test procedures for the Agilent E5070A/E5071A RF Network Analyzers. The performance test names are listed in Table 2-1. The test procedures are described sequentially in the following pages.

The test name indicates the tested performance and to which performance group the tested performance belongs.

Each procedure consists of the following parts:

- Description:** describes the test procedure
- Specification:** describes the performance verified in the test.
- Test Equipment:** describes test equipment required in the test.
- Procedure:** describes test procedure step by step.

NOTE Allow the analyzer to warp up for at least 30 minutes before you execute any of the performance tests.

Perform all performance tests in an ambient temperature of 23 ± 5 °C

NOTE The performance tests should be performed periodically. The recommended test interval is 12 months.

The test interval depends on maintenance of use and the environmental conditions under which the instrument is used. You may find that the interval could be shortened or lengthened; however, such a decision should be based on substantial quantitative data.

NOTE Before performing any tests, make extra copies of the calculation sheet and the performance test record pertaining to the test procedure. These are required in the test procedure. For explanation of how to use these records, see the calculation sheet and performance test record at the end of this literature.

NOTE All the test procedures are described without using the optional touch screen LCD features (option 016) of the E5070A/E5071A. For the option 016 instruments, the touch screen operating procedures corresponding to the described procedures may be used.

Table 2-1 The E5070A/E5071A performance test procedure

Para.	Title
1	Frequency accuracy test
2	RF output level accuracy and flatness test
3	RF output level linearity test
4	Trace noise CW test
5	Crosstalk test
6	System dynamic range test

Table 2-1

The E5070A/E5071A performance test procedure

Para.	Title
7	Dynamic accuracy test
8	Uncorrected system performance test

Test Equipment Required

The required equipment for the performance test is listed on Table 1-1 and Table 1-2. Use only calibrated equipment when doing the performance test.

1. FREQUENCY ACCURACY TEST

Description

This test checks the frequency accuracy of the E5070A/E5071A test port output signal. The frequency accuracy is checked at 50 MHz and 3 GHz with a frequency counter. Since the E5070A/E5071A employs a PLL frequency synthesizer for the signal source, the frequency accuracy test at these two frequency points can verify the accuracy for the entire frequency range.

Specification

@23 ± 5 °C, referenced to 23 °C

Frequency accuracy	≤ ± 5 ppm @ 300 kHz to 3 GHz (E5070A)
	≤ ± 5 ppm @ 300 kHz to 8.5 GHz (E5071A)

@23 ± 5 °C, referenced to 23 °C

High stability time-base accuracy (option 1E5)	≤ ± 1 ppm @ 300 kHz to 3 GHz (E5070A)
	≤ ± 1 ppm @ 300 kHz to 8.5 GHz (E5071A)

Test equipment

Frequency Counter	Agilent 53181A with Opt. 010 and 030
BNC cable, 61 cm	PN 8120-1839
N(m)-BNC(f) adapter	PN 1250-0780

Procedure

- Step 1.** Connect the test equipment as shown in Figure 2-1. For testing the E5070A/E5071A equipped with option 1E5, connect a BNC cable between the Ref In connector and the Ref Oven (10 MHz) connector on the E5070A/E5071A rear panel.

NOTE For testing without option 1E5, disconnect the above BNC cable.

NOTE Figure 2-1 shows the test setup for the E5070A/E5071A with 4-port option (Opt. 413/414). For 2-port and 3-port options (Opt. 213/214/313/314), connect the frequency counter input cable to Port 1 as well.

Figure 2-1 Frequency accuracy test setup (50 MHz)

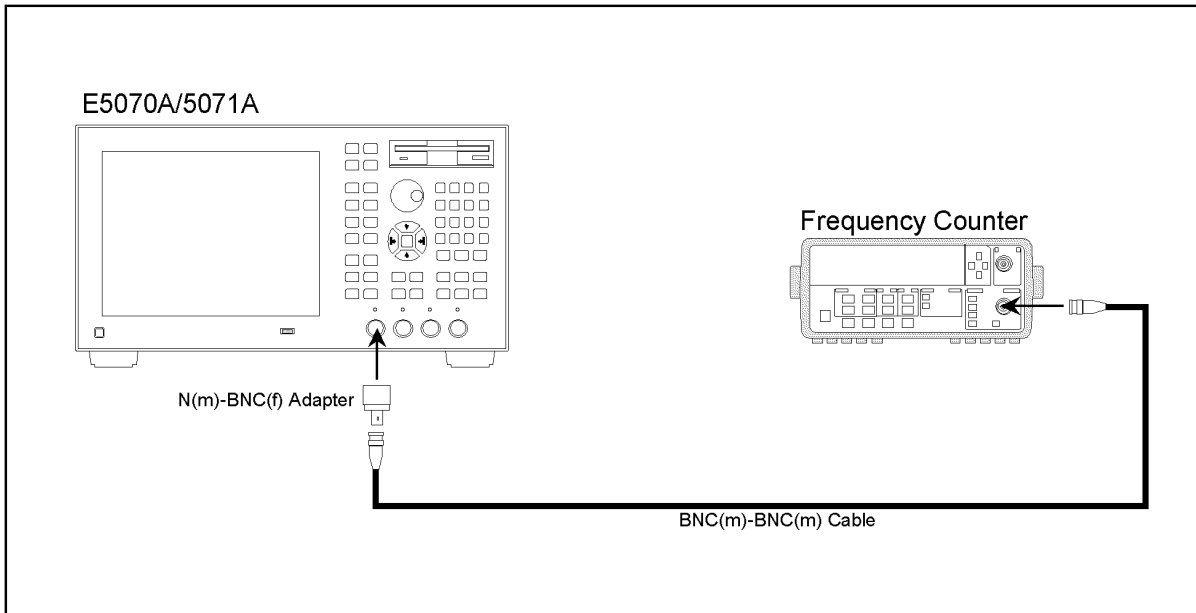

e5070ase006

2. Performance Test

Step 2. Initialize the frequency counter. Set the frequency counter as follows:

Controls	Setting
Gate time	1 sec
50 Ω/1 MΩ	50 Ω

Step 3. Press **Preset** and **Enter** to initialize the E5070A/E5071A. Then set the controls as follows:

Control settings	Key strokes
Center frequency: 50 MHz	Center - 5 - 0 - M/μ
Frequency span: 0 Hz	Span - 0 - x1

The source power now is set to 0 dBm (preset value).

Step 4. Press **Trigger** - **↓** and **Enter** to make a **Single** sweep measurement. Wait for frequency counter reading to settle.

Step 5. Record the frequency counter reading to a 1 Hz resolution in the performance test record ("Test result" column for the Frequency accuracy test.)

Performance Tests
1. FREQUENCY ACCURACY TEST

Figure 2-2 Frequency accuracy test setup (3GHz)

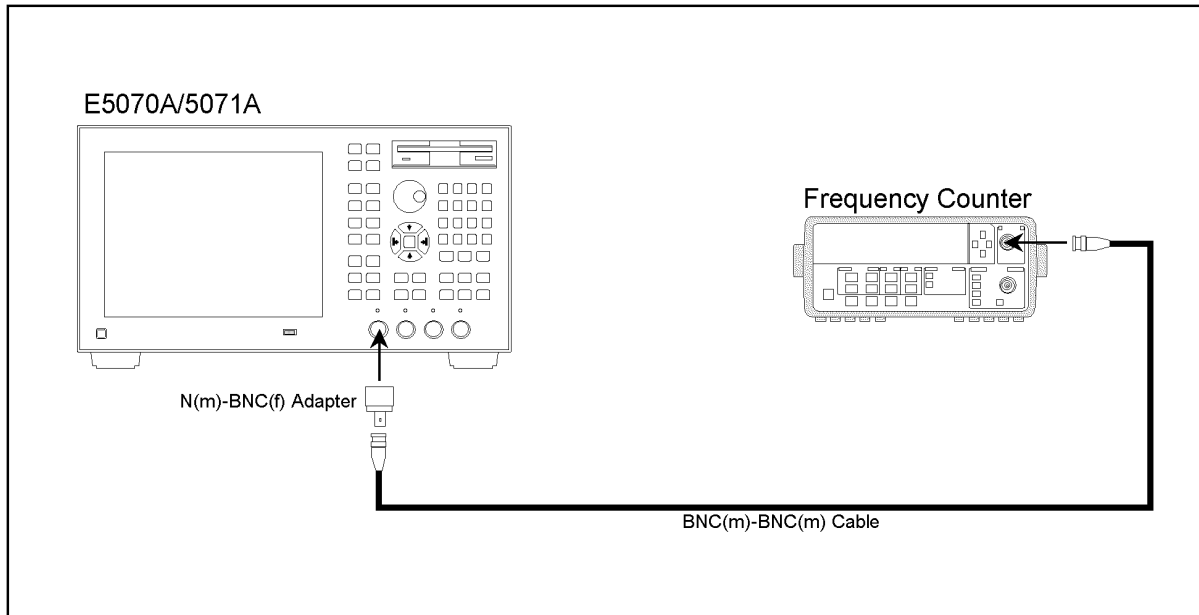

e5070ase034

Step 6. Connect the BNC cable to the frequency counter input channel measurable for a 3 GHz input signal. See Figure 2-2.

Step 7. Press **Center** - **3** - **G/n** to set the frequency to 3 GHz.

Step 8. Perform Step 4 and 5.

2. RF OUTPUT LEVEL ACCURACY AND FLATNESS TEST

Description

This test checks the level accuracy and frequency flatness of the E5070A/E5071A test port output signal. The level accuracy is checked for an output power level setting of 0 dBm at 50 MHz using a power meter. The frequency flatness is tested by measuring the power level at 12 frequency points from 10 MHz to 8.5 GHz and calculating the differences of the power meter readings from the level at 50 MHz.

Specification

Level accuracy

$\leq \pm 0.65 \text{ dBm @ } 23 \pm 5 \text{ }^\circ\text{C, 50 MHz, 0 dBm}$

Flatness

E5070A

$\leq \pm 1 \text{ dBm @ } 23 \pm 5 \text{ }^\circ\text{C, 10 MHz to 3 GHz, 0 dBm, relative to 50 MHz}$

E5071A

$\leq \pm 1 \text{ dBm @ } 23 \pm 5 \text{ }^\circ\text{C, 10 MHz to 8.5 GHz, 0 dBm, relative to 50 MHz}$

NOTE

The level accuracy and flatness specifications apply to Port 1 only. The levels for other ports are given as supplemental performance characteristic.

Test equipment

Power meter	Agilent E4419A/B
Power sensor	Agilent E4412A

Procedure

- Step 1.** Connect the power sensor to the power meter. Calibrate the power meter for the power sensor used.
- Step 2.** Connect the test equipment as shown in Figure 2-3.

2. RF OUTPUT LEVEL ACCURACY AND FLATNESS TEST

Figure 2-3 RF output level accuracy and flatness test setup.

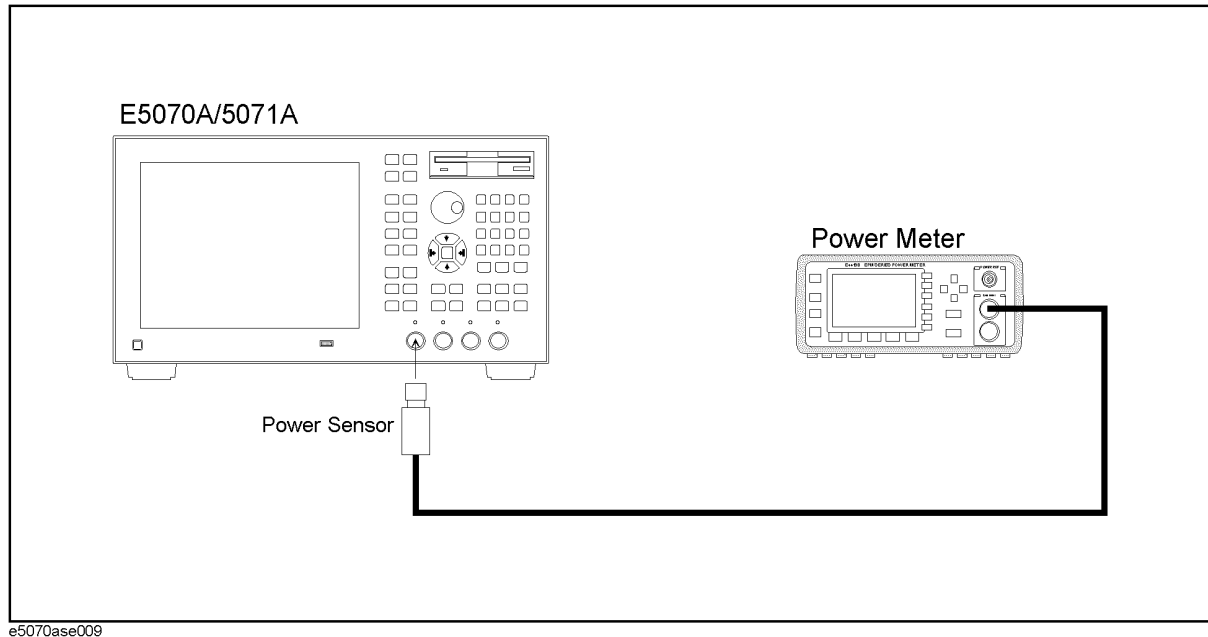

e5070ase009

NOTE

Figure 2-3 shows the test setup for the E5070A/E5071A with 4-port option (Opt. 413/414). For 2-port and 3-port options (Opt. 213/214/313/314), connect the power sensor to Port 1 as well.

Step 3. Press **Preset** and **Enter** to initialize the E5070A/E5071A. Then set the controls as follows:

Control settings	Key strokes
Center frequency: 50 MHz	Center - 5 - 0 - M/μ
Frequency span: 0 Hz	Span - 0 - x1

The source power now is set to 0 dBm (preset value).

Step 4. Press **Trigger** - **↓** and **Enter** to make a **Single** sweep measurement.

Step 5. RF output level accuracy test

- Wait for power meter reading to settle.
- Record the power meter reading in the performance test record ("Test result" column for the level accuracy test).

Step 6. RF output level flatness test

- Record the power meter reading (same as that in Step 5-b) in the calculation sheet ("Power meter reading [Ref]" column for the level flatness test).
- Press **Center** - **1** - **0** - **M/μ** to change the E5070A/E5071A center frequency to 10 MHz, which is the first one of the frequency flatness test frequencies listed in Table

2. RF OUTPUT LEVEL ACCURACY AND FLATNESS TEST

2-2.

Table 2-2

RF output level flatness test conditions

Agilent E5070A/E5071A Center Frequency	
E5070A/E5071A	10 MHz 550 MHz 1.05 GHz 1.55 GHz 2.05 GHz 3 GHz
E5071A only	4.25 GHz 5.05 GHz 6.05 GHz 7.05 GHz 8.05 GHz 8.5 GHz

NOTE

The RF output level is measured at the minimum, maximum and proper frequencies other than the source adjustment frequencies within the specified frequency range.

- c. Press **Trigger** -  and **Enter** to make a **Single** sweep measurement.
- d. Wait for the power meter reading to settle. Then record the reading in the calculation sheet ("Power meter reading [a]" column).
- e. Change the E5070A/E5071A center frequency in accordance with Table 2-2 and perform Step 6-c and 6-d for each frequency.
- f. Calculate test results using the equation given in the calculation sheet. Record the calculated test results in the performance test record ("Test result" column for the level flatness test).

3. RF OUTPUT LEVEL LINEARITY TEST

Description

This test checks the level accuracy of the E5070A/E5071A test port output signal across the specified level range. The RF output level is measured for power level settings of -15 dBm to 0 dBm in 1 dB step increments at 10MHz, 3 GHz, 4.25 GHz and 8.5 GHz.

Specification

E5070A

$\leq \pm 0.75$ dBm @ 23 ± 5 °C, 10 MHz to 3 GHz, - 15 dBm to 0 dBm

E5071A

$\leq \pm 0.75$ dBm @ 23 ± 5 °C, 10 MHz to 4.2 GHz, - 15 dBm to 0 dBm

$\leq \pm 1.5$ dBm @ 23 ± 5 °C, 4.2 GHz to 8.5 GHz, - 10 dBm to 0 dBm

$\leq \pm 3$ dBm @ 23 ± 5 °C, 4.2 GHz to 8.5 GHz, - 15 dBm to - 10 dBm

NOTE

The level linearity specification applies to Port 1 only. The levels for other ports are given as supplemental performance characteristic.

Test equipment

Power meter	Agilent E4419A/B
Power sensor	Agilent E4412A

Procedure

- Step 1.** Connect the power sensor to the power meter. Calibrate the power meter for the power sensor used.
- Step 2.** Connect the test equipment as shown in Figure 2-4.

Figure 2-4 RF output level linearity test setup

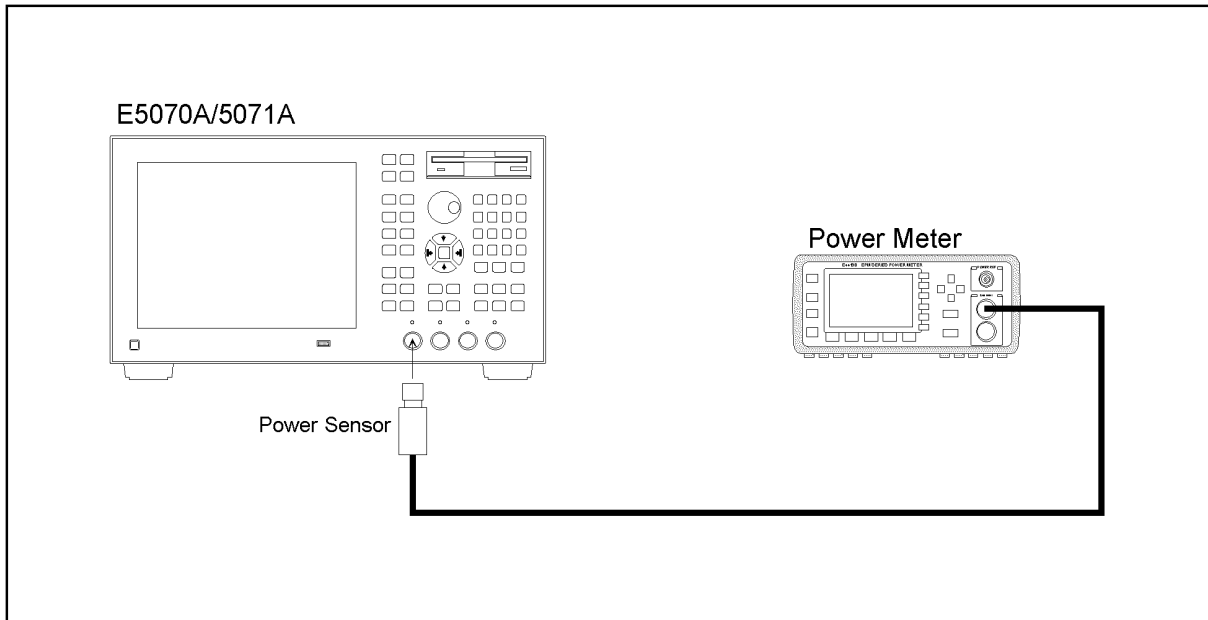

e5070ase009

2. Performance Test

NOTE

Figure 2-4 shows the test setup for the E5070A/E5071A with 4-port option (Opt. 413/414). For 2-port and 3-port options (Opt. 213/214/313/314), connect the power sensor to Port 1 as well.

Step 3. Press **Preset** and **Enter** to initialize the E5070A/E5071A. Then set the controls as follows:

Control settings	Key strokes
Center frequency: 10 MHz	Center - 1 - 0 - M/μ
Frequency span: 0 Hz	Span - 0 - x1

The source power now is set to 0 dBm (preset value).

Step 4. Press **Trigger** - **↓** and **Enter** to make a **Single** sweep measurement.

Step 5. Wait for power meter reading to settle. Record the power meter reading in the calculation sheet ("Power meter reading [Ref]" column for the level linearity test).

Step 6. Press **Sweep Setup** - **+/-** - **1** - **x1** to set the power level to -1 dBm, which is the second

3. RF OUTPUT LEVEL LINEARITY TEST

value of the level linearity test levels listed in Table 2-3.

Table 2-3

RF output level linearity test conditions

Test frequency	E5070A/E5071A		E5071A only	
	10 MHz	3 GHz	4.25 GHz	8.5 GHz
Power level	0 dBm (reference level) -1 dBm -2 dBm -3 dBm -4 dBm -5 dBm -6 dBm -7 dBm -8 dBm -9 dBm -10 dBm -11 dBm -12 dBm -13 dBm -14 dBm -15 dBm			

NOTE

The RF output level linearity is tested at the minimum, maximum and proper frequencies other than the source adjustment frequencies within the specified frequency range.

- Step 7.** Press **Trigger** - **↓** and **Enter** to make a **Single** sweep measurement.
- Step 8.** Wait for the power meter reading to settle. Then record the reading in the calculation sheet ("Power meter reading [a]" column for the level linearity test).
- Step 9.** Change the E5070A/E5071A power level setting in accordance with Table 2-3 and perform Step 7 and 8 for each power level to -15 dBm.
- Step 10.** Set the power level to 0 dBm and change the E5070A/E5071A center frequency to the next level-linearity test frequency in accordance with Table 2-3.
- Step 11.** Perform Step 4 through 10 for each frequency.
- Step 12.** Calculate test results using the equation given in the calculation sheet. Record the calculated test results in the performance test record ("Test result" column for the level linearity test).

4. TRACE NOISE CW TEST

Description

This test checks the trace noise level for each test port of the E5070A/E5071A. The trace noise level is quantified by performing a "through" measurement 32 times at 3 MHz, 1.3 GHz, 2.1 GHz, 3 GHz, 4.25 GHz, 7.5 GHz and 8.5 GHz, with a cable connected between two test ports. Standard deviation of the measured values at each frequency is calculated and, then translated into a noise level expressed in dB rms.

Specification

E5070A

≤ 1 mdB rms @ 23 ± 5 °C, 3 MHz to 3 GHz, IFBW 3 kHz, 0 dBm, through

E5071A

≤ 1 mdB rms @ 23 ± 5 °C, 3 MHz to 4.2 GHz, IFBW 3 kHz, 0 dBm, through

≤ 3 mdB rms @ 23 ± 5 °C, 4.2 GHz to 7.5 GHz, IFBW 3 kHz, 0 dBm, through

≤ 5 mdB rms @ 23 ± 5 °C, 7.5 GHz to 8.5 GHz, IFBW 3 kHz, 0 dBm, through

Test equipment

Coaxial cable with Type-N (m) connectors, 61 cm (24 in)	N6314A(p/n 8120-8862)
---	--------------------------

Procedure

Step 1. Connect test equipment (N-N cable) as shown the following figures:

Opt. 213/214: Figure 2-5

Opt. 313/314: Figure 2-6

Opt. 413/414: Figure 2-7

Performance Tests
4. TRACE NOISE CW TEST

Figure 2-5 Trace noise CW test setup (Opt. 213/214)

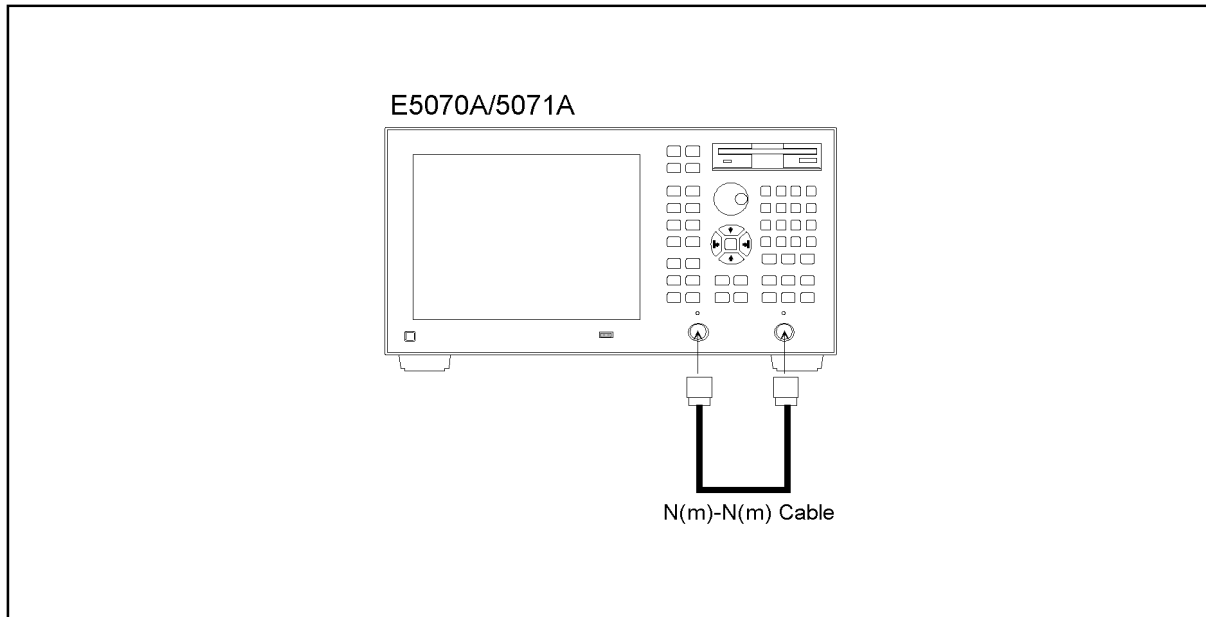

e5070ase010

Figure 2-6 Trace noise CW test setup (Opt. 313/314)

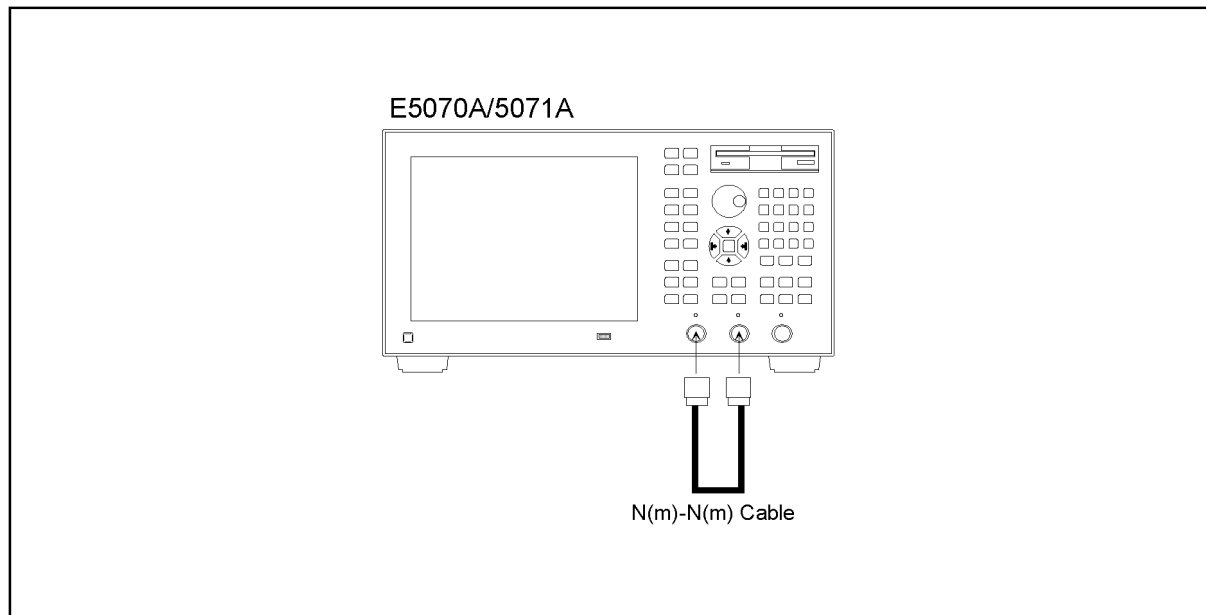

e5070ase011

Figure 2-7 Trace noise CW test setup (Opt. 413/414)

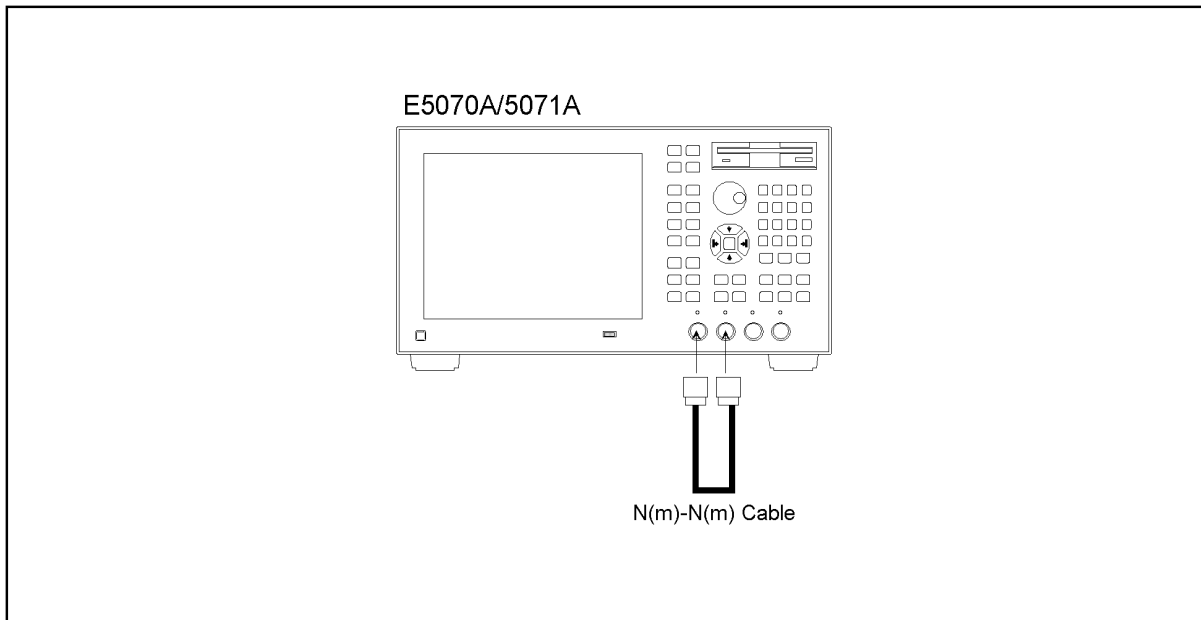

e5070ase013

2. Performance Test

NOTE Do not touch or move the N-N cable during measurements. To do so will cause a variance in measured values.

- Step 2.** Press **Preset** and **Enter** to initialize the E5070A/E5071A.
- Step 3.** Press **Format** - **↓** - **↓** - **↓** - **↓** - **↓** - **Enter** to select **Lin Mag** from display format menu.
- Step 4.** Press **Marker Fctn** - **↓** - **↓** - **↓** - **↓** - **↓** - **↓** - **↓** - **↓** (select **Statistics**) - **Enter** and set **Statistics** function to on.
- Step 5.** Press **Meas** and select **S21** from S-parameter menu.
- Step 6.** Set the controls as follows:

Control settings	Key strokes
Center frequency: 3 MHz	Center - 3 - M/μ
Frequency span: 0 Hz	Span - 0 - x1
Number of points: 32	Sweep Setup - ↓ - ↓ - ↓ - ↓ - ↓ (select Points) - Enter - 3 - 2 - x1
IF Bandwidth: 3 kHz	Avg - Enter - 3 - k/m

The source power now is set to 0 dBm (preset value).

- Step 7.** Press **Trigger** - **↓** and **Enter** to make a **Single** sweep measurement. A "s.dev" (standard deviation) value will be displayed in the upper left corner of the graphic display.

Performance Tests

4. TRACE NOISE CW TEST

- Step 8.** Record the s.dev value in the calculation sheet ("s.dev [μ U]" column for the trace noise CW test).
- Step 9.** Calculate the dB value of the trace noise level using the following equation and record the calculated value in the calculation sheet ("Trace noise level [dB rms]" column).

$$\text{Trace noise level} = 20 \log (1 + \text{s.dev} \times 10^{-6})$$

- Step 10.** Change the E5070A/E5071A center frequency in accordance with Table 2-4 and perform Step 7 through 9 for each frequency.

Table 2-4 Trace noise CW test frequencies

	Center frequency setting
E5070A/E5071A	1.3 GHz 2.1 GHz 3 GHz
E5071A only	4.25 GHz 7.5 GHz 8.5 GHz

NOTE

The CW trace noise level is tested at the minimum and maximum frequencies of the specified frequency range, the frequencies where an internal frequency divider works (between 1.3 GHz and 2.1 GHz) and, the frequency where the signal source frequency band is switched (4.25 GHz).

- Step 11.** Record the calculated values of the trace noise level in the performance test record ("Test result [dB rms]" column for the trace noise CW test).
- Step 12.** Press **Meas** and select **S12** from S-parameter menu.
- Step 13.** Press **Center** - **3** - **M/ μ** to set the frequency to 3 MHz.
- Step 14.** Perform Step 7 through 11 for the S12 measurement.

Options 313, 314, 413 and 414 only

NOTE

Perform Step 15 through 18 for the option 313, 314, 413 and 414 instruments only.

- Step 15.** Connect the test equipment (N-N cable) as shown in Figure 2-8 (Opt. 313/314) and Figure 2-9 (Opt. 413/414).

Figure 2-8 Trace noise CW test setup (Opt. 313/314)

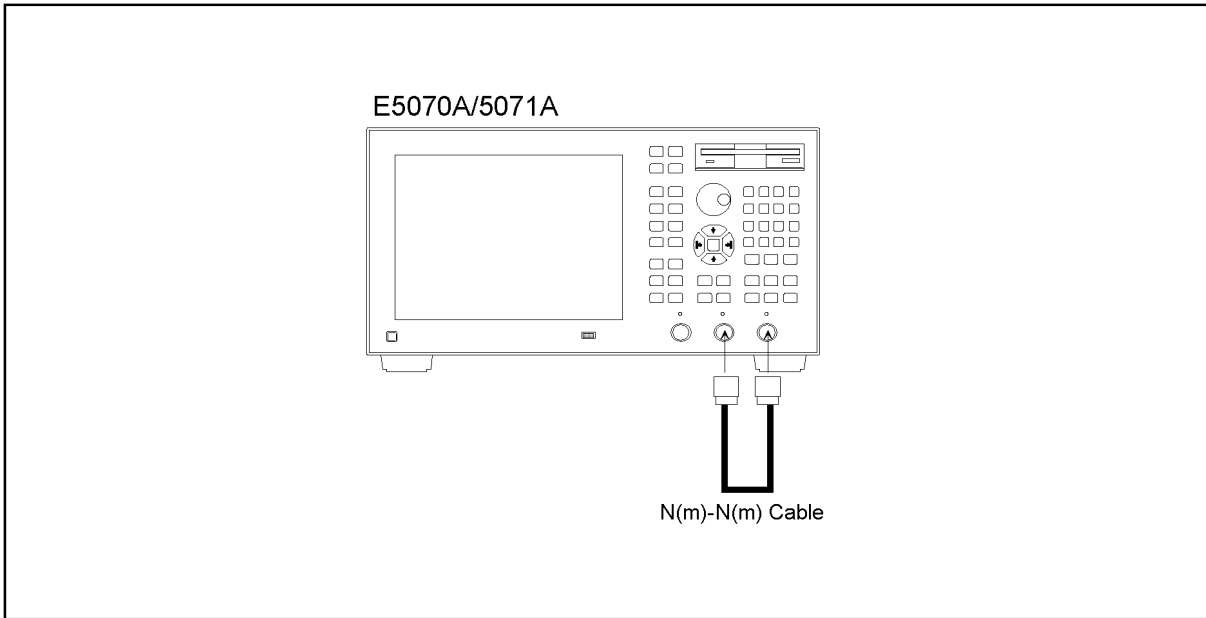

e5070ase012

Figure 2-9 Trace noise CW test setup (Opt. 413/414)

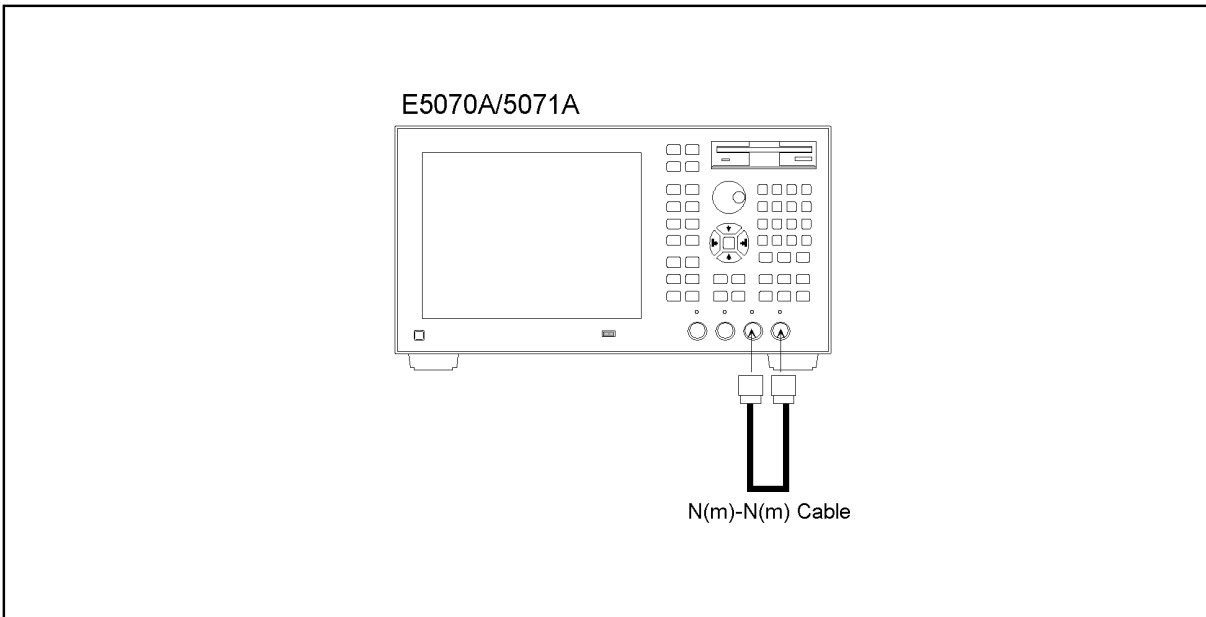

e5070ase014

Step 16. Select S-parameter from menu in accordance with Table 2-5.

Performance Tests
4. TRACE NOISE CW TEST

Table 2-5 S-parameter settings for trace noise CW test

	Option	
	313/314	413/414
1	S23	S43
2	S32	S34

- Step 17.** Set the center frequency to 3 MHz.
- Step 18.** Perform Step 7 through 11 for each of the S-parameters shown in the first and second rows in Table 2-5.

5. CROSSTALK TEST

Description

This test checks the crosstalks between test ports of the E5070A/E5071A. The crosstalk is tested by performing "through" measurements with two test ports connected together and, short-ended "isolation" measurements with the test ports terminated with N-type "Short" devices. A "through" calibration is performed to have the through measurement data as the reference to which the isolation measurement data is compared. With a setting of 101 sweep points for a specified frequency range, a swept measurement with the short-ended test ports is repeated 16 times and the measurement data is averaged. The worst crosstalk value is determined from the peak value of the average data.

Specification

E5070A

-120 dB @ 23 ± 5 °C, 3 MHz to 3 GHz, IFBW 10 Hz, 0 dBm

E5071A

-120 dB @ 23 ± 5 °C, 3 MHz to 3 GHz, IFBW 10 Hz, 0 dBm

-110 dB @ 23 ± 5 °C, 3 GHz to 6 GHz, IFBW 10 Hz, 0 dBm

-100 dB @ 23 ± 5 °C, 6 GHz to 7.5 GHz, IFBW 10 Hz, 0 dBm

-90 dB @ 23 ± 5 °C, 7.5 GHz to 8.5 GHz, IFBW 10 Hz, 0 dBm

The crosstalk specification applies when response calibration is performed.

Test equipment

Coaxial cable with Type-N (m) connectors, 61 cm (24 in)	N6314A(p/n 8120-8862)
Type-N(m) coaxial Short termination (4 ea.)	part of 85032F/54D/3 3E/50D with Type-N adapter

Procedure

Step 1. Connect the N-N cable as shown in the following figures:

Opt. 213/214: Figure 2-10

Opt. 313/314: Figure 2-11

Opt. 413/414: Figure 2-12

Performance Tests
5. CROSSTALK TEST

Figure 2-10 Response calibration setup for crosstalk test (Opt.213/214)

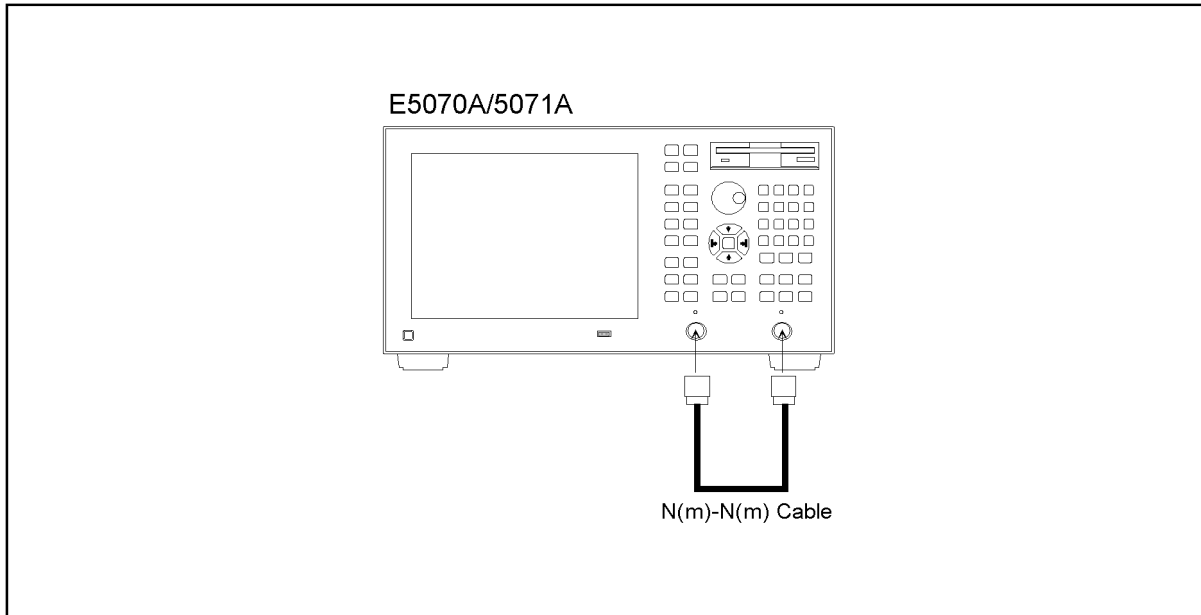

e5070ase010

Figure 2-11 Response calibration setup for crosstalk test (Opt.313/314)

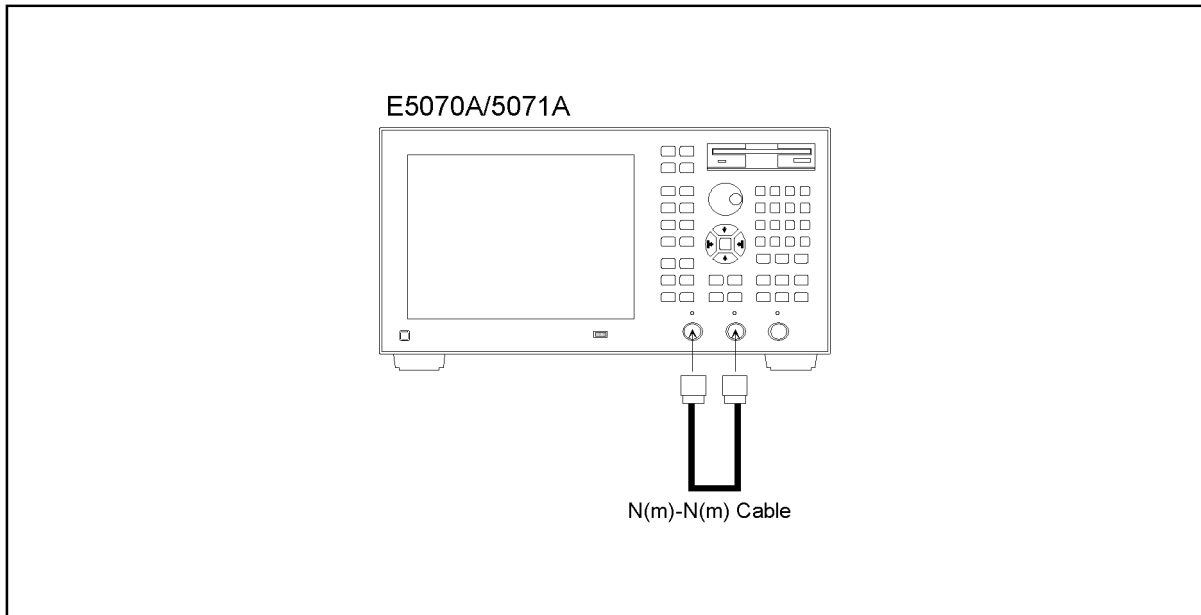

e5070ase011

Figure 2-12 Response calibration setup for crosstalk test (Opt.413/414)

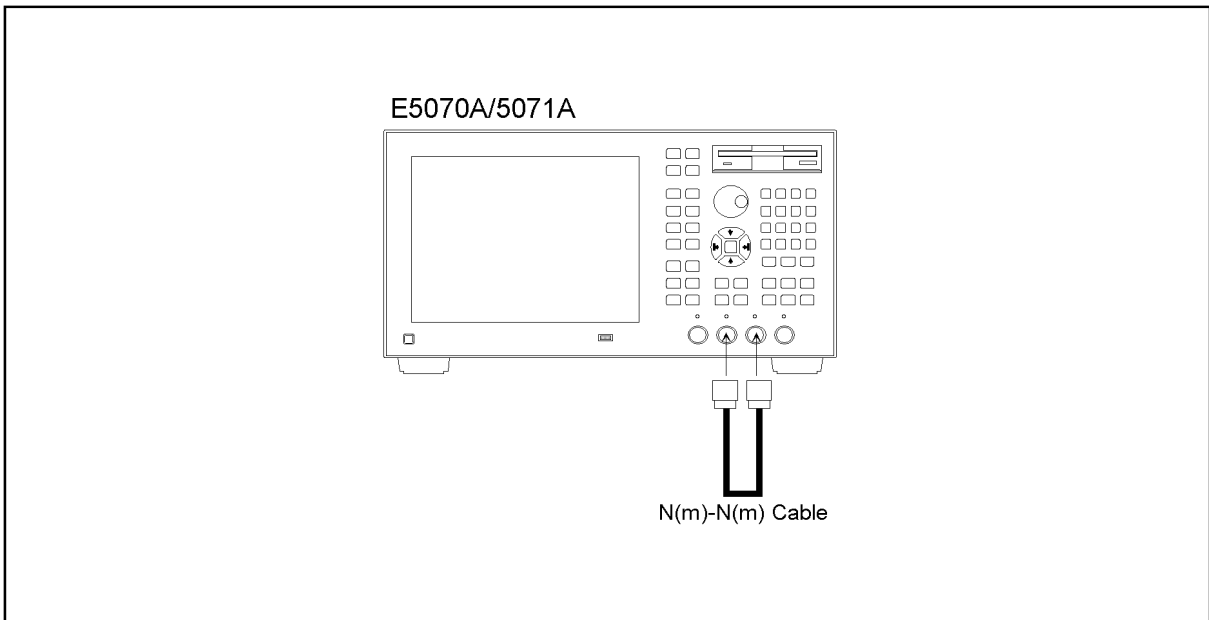

e5070ase018

2. Performance Test

NOTE Do not touch or move the N-N cable during measurements. To do so will cause a variance in measured values.

Step 2. Press **Preset** and **Enter** to initialize the E5070A/E5071A.

Step 3. Press **Format** and select **Lin Mag** from display format menu.

Step 4. Set the controls as follows:

Control settings

Key strokes

IF Bandwidth: 10 Hz

Avg - **Enter** - **1** - **0** - **x1**

Averaging: ON

↑ - **↑** - **↑** (select **Averaging**) - **Enter**

Averaging factor now is set to 16 (preset value).

Number of points: 101

Sweep Setup - **↓** - **↓** - **↓** - **↓** - **↓** (select **Points**) - **Enter** - **1** - **0** - **1** - **x1**

The source power now is set to 0 dBm (preset value).

Response calibration

Step 5. Press **Cal** - **↓** - **↓** - **↓** - **↓** and **Enter** to select **Cal Kit**.

Step 6. Press **↓** - **↓** - **↓** and **Enter** to select **85032F**.

NOTE If **Cal Kit** is set to **85032F***, press **↓**, **Enter**, **↓** - **↓** - **↓** - **Enter** - **Enter** to

Performance Tests
5. CROSSTALK TEST

select **Restore Cal Kit**.

Step 7. Press **Cal** - **↓** and **Enter** to select **Calibrate** function.

Step 8. Press **↓** - **↓** and **Enter** to select **Response (Thru)** calibration.

Step 9. Press **Enter** to go down to **Select Ports** menu.

Step 10. Select **2-1 (S21)** for the option 213/214/313/314 instruments and **3-2 (S32)** for the option 413/414 instruments as shown in the first row in Table 2-6.

Table 2-6

Select Ports settings for response calibration

	Option		
	213/214	313/314	413/414
1	2-1(S21)	2-1(S21)	3-2 (S32)
2	1-2 (S12)	1-2 (S12)	2-3 (S23)
3	Not required	3-2 (S32)	4-1 (S41)
4	Not required	2-3 (S23)	1-4 (S14)

Step 11. Press **↓** and **Enter** to perform **Thru** calibration. Wait until the calibration is completed.

Step 12. Press **↓** - **↓** and **Enter** to perform **Done**.

Step 13. Change **Select Ports** setting as shown in the second row in Table 2-6.

Step 14. Perform Step 11 and 12.

Step 15. For the option 213/214 instruments, skip to Step 18. For the option 313/314/413/414, proceed to Step 16.

Response calibration for options 313, 314, 413 and 414 only

Step 16. Connect the test equipment (N-N cable) as shown in Figure 2-13 (Opt. 313/314) and Figure 2-14 (Opt. 413/414).

Figure 2-13 Response calibration setup for crosstalk test (Opt.313/314)

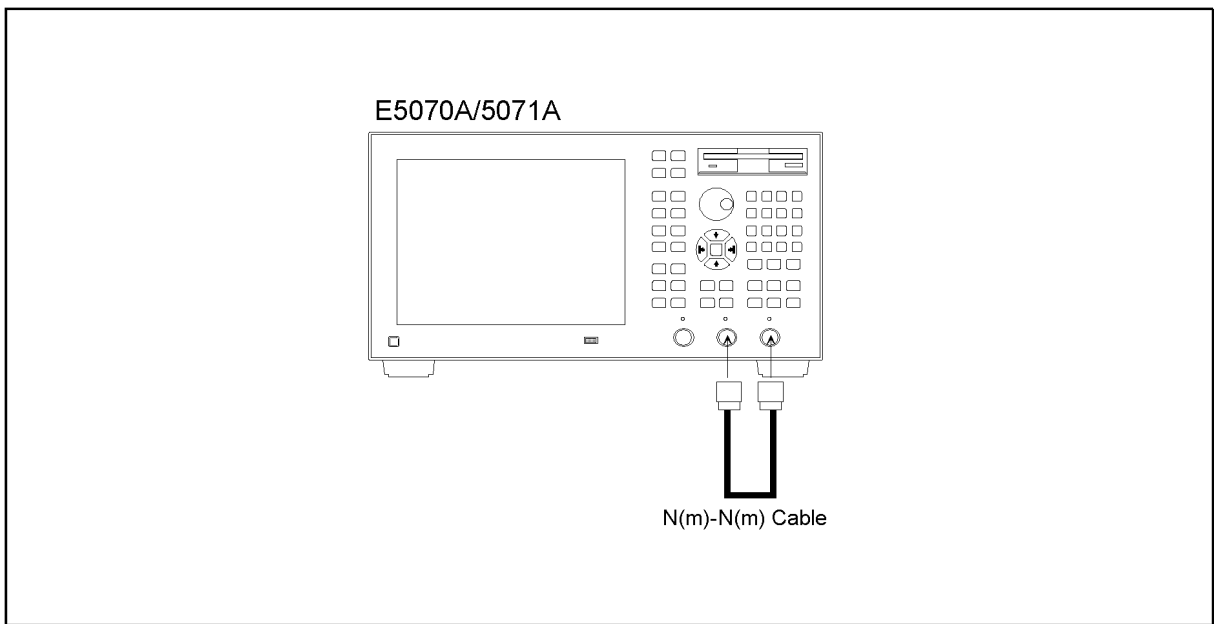

e5070ase012

Figure 2-14 Response calibration setup for crosstalk test (Opt.413/414)

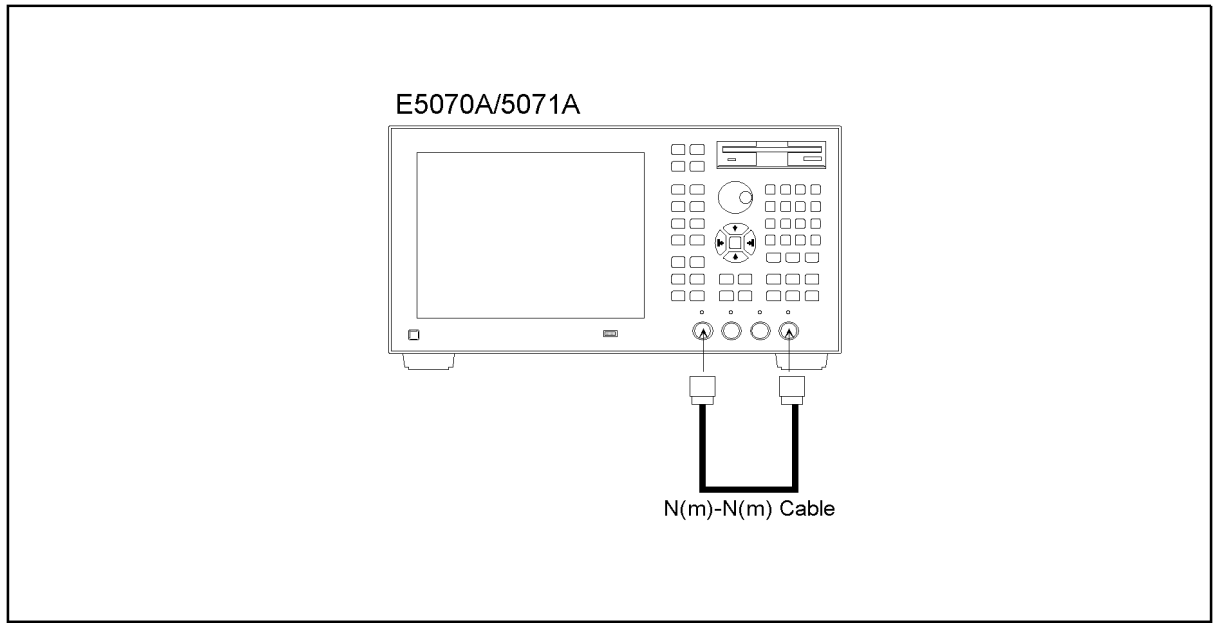

e5070ase017

Step 17. Perform the response calibration for each of the **Select Ports** settings shown in the third and fourth rows in Table 2-6.

Crosstalk measurement

Step 18. Press and verify that **Correction** is set to **ON**.

Step 19. Disconnect the N-N cable and connect an N-type coaxial Short termination to each test port as shown in the following figures:

Performance Tests
5. CROSSTALK TEST

Opt. 213/214: Figure 2-15
Opt. 313/314: Figure 2-16
Opt. 413/414: Figure 2-17

Figure 2-15 Crosstalk test setup (Opt. 213/214)

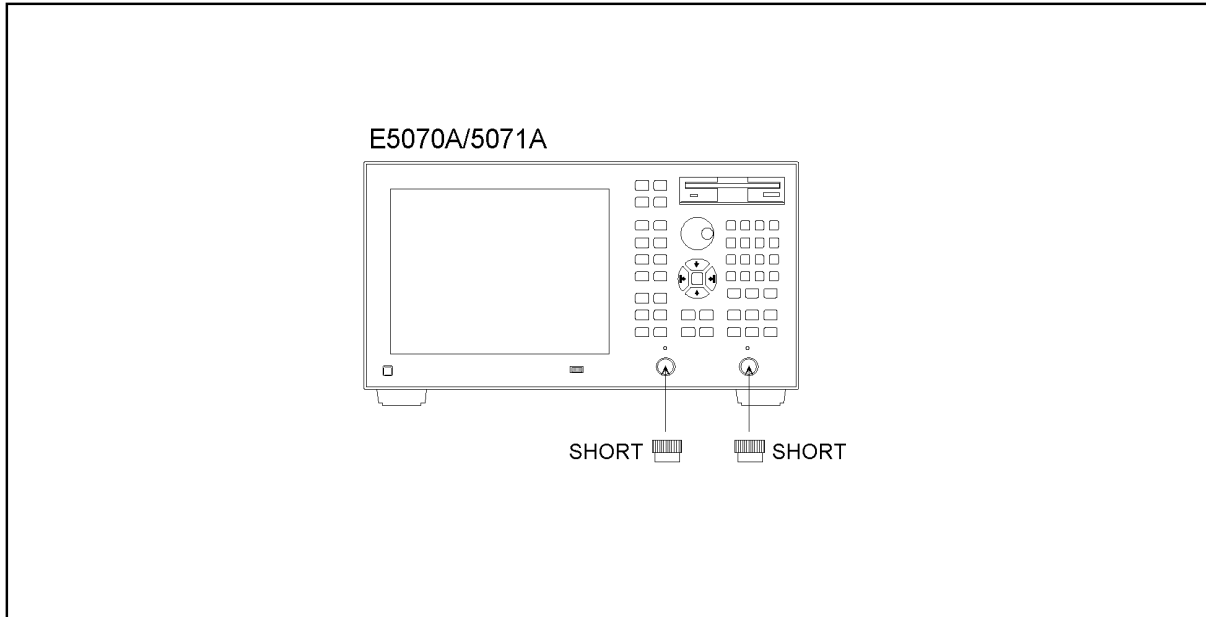

e5070ase015

Figure 2-16 Crosstalk test setup (Opt. 313/314)

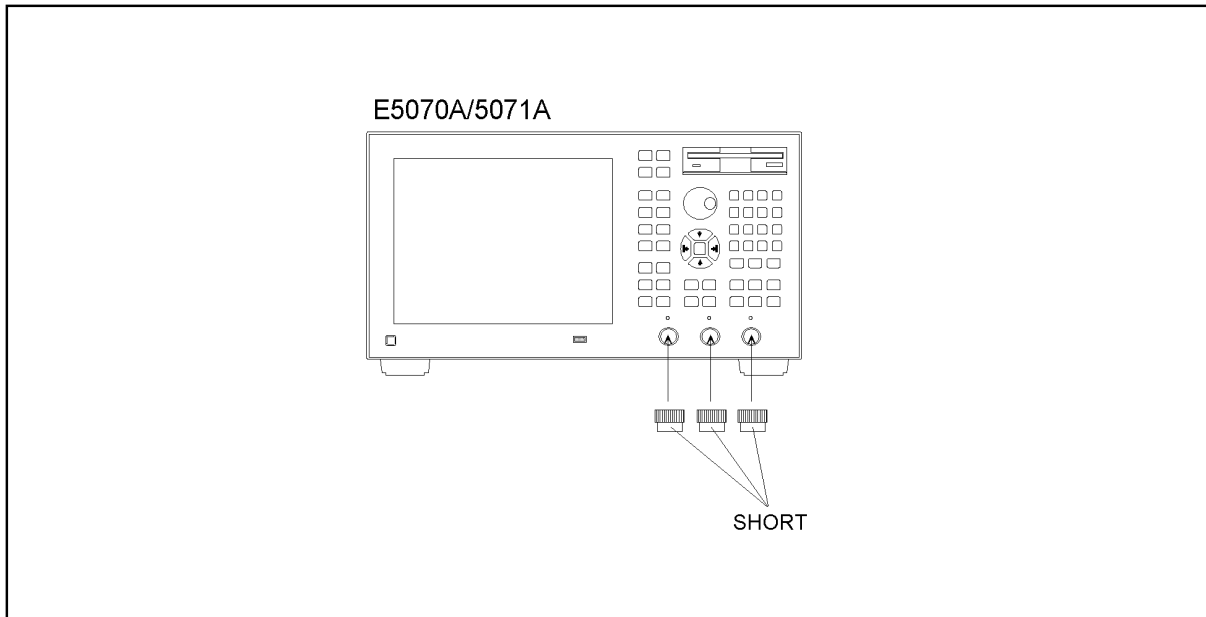

e5070ase016

Figure 2-17 Crosstalk test setup (Opt. 413/414)

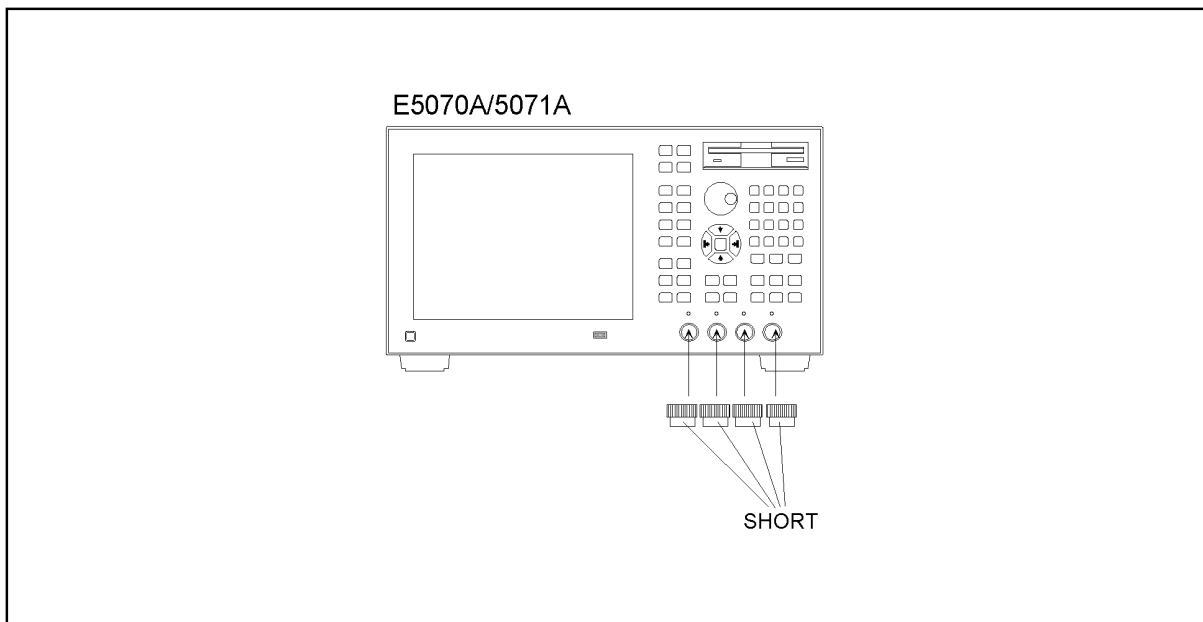

e5070ase019

2. Performance Test

Step 20. Program or download the VBA test program shown in Program 2-1.

NOTE

Also set a UserForm window to enable the test result output data to be displayed. An example of the UserForm window is shown in Figure 2-18. Refer to the Agilent E5070A/E5071A VBA Programmer's Guide for the UserForm setup procedure.

Step 21. Press **Meas** and select the following S-parameter from menu:

- Option 213/214/313/314: **S21**
- Option 413/414: **S32**

These parameters are shown in the first row in Table 2-7.

Table 2-7

S-parameter settings for crosstalk tests.

	Option		
	213/214	313/314	413/414
1	S21	S21	S32
2	S12	S12	S23
3	Not required	S32	S41
4	Not required	S23	S14

Step 22. Press **Avg** - **↑** - **↑** - **↑** - **↑** - **↑** (select Averaging Restart) **Enter** to restart the swept measurements. Wait until a trace for the average of 16 swept measurements is displayed.

Performance Tests

5. CROSSTALK TEST

NOTE

The number of averaging times is displayed in the status bar of the measurement channel window.

Step 23. Press **Trigger** and **Enter** to set the trigger operation to **Hold** mode.

Step 24. Press **Macro Run** to execute the test program. This test program searches the maximum point of the trace for each of the following frequency ranges.

E5070A: 3 MHz to 3 GHz (one range only)

E5071A: 3 MHz to 3 GHz, 3 GHz to 6 GHz, 6 GHz to 7.5 GHz and 7.5 GHz to 8.5 GHz (four ranges)

The test results are represented in dB and displayed in the VBA UserForm window as shown in the display example below.

Figure 2-18

VBA UserForm window display example

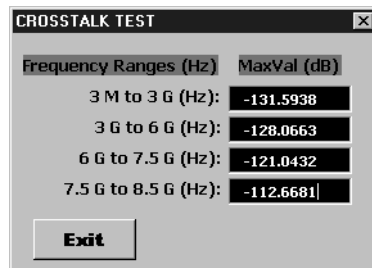

Step 25. Read the maximum value(s) and record them in the performance test record ("Test result [dB]" column for the crosstalk test).

Step 26. Press **Exit** button on the CROSSTALK TEST window.

Step 27. Press **Trigger** - **Down Arrow** - **Down Arrow** - **Enter** to select the **Continuous** trigger mode.

Step 28. Change the S-parameter setting in accordance with Table 2-7 (the second through fourth rows) and perform Step 22 through Step 27.

Crosstalk test program

Coding procedure:

Step 1. Press **Macro Setup** key.

Step 2. Press **Enter** to activate **VBA Editor** function.

Step 3. Click **Insert** and select **Module** from pull-down menu. VBA Project - Module1 [Code] window screen for coding a program will be displayed.

Step 4. Input the test program shown below.

Step 5. Save the test program with a proper file name.

Program 2-1

Test Program:

```
Sub Main()
```

```
Dim Ver As String
Dim MaxValA As Variant
Dim MaxValB As Variant, MaxValC As Variant, MaxValD As Variant,
MaxValE As Variant

Ver = Name

If Ver = "E5070A" Then
    SCPI.CALCulate(1).PARAmeter(1).SElect
    SCPI.CALCulate(1).SElected.FUNction.TYPE = "MAX"
    SCPI.CALCulate(1).SElected.FUNction.DOMain.START = 3000000#
    SCPI.CALCulate(1).SElected.FUNction.DOMain.STOP = 3000000000#
    SCPI.CALCulate(1).SElected.FUNction.DOMain.STATe = True
    SCPI.CALCulate(1).SElected.FUNction.EXECute
    MaxValA = SCPI.CALCulate(1).SElected.FUNction.DATA

    frmCrossTalk1.txtVal.Text = CSng(20 * Log10(MaxValA(0)))
    frmCrossTalk1.Show

ElseIf Ver = "E5071A" Then
    SCPI.CALCulate(1).PARAmeter(1).SElect
    SCPI.CALCulate(1).SElected.FUNction.TYPE = "MAX"
    SCPI.CALCulate(1).SElected.FUNction.DOMain.START = 3000000#
    SCPI.CALCulate(1).SElected.FUNction.DOMain.STOP = 3000000000#
    SCPI.CALCulate(1).SElected.FUNction.DOMain.STATe = True
    SCPI.CALCulate(1).SElected.FUNction.EXECute
    MaxValB = SCPI.CALCulate(1).SElected.FUNction.DATA

    SCPI.CALCulate(1).SElected.FUNction.DOMain.START = 3000000000#
    SCPI.CALCulate(1).SElected.FUNction.DOMain.STOP = 6000000000#
    SCPI.CALCulate(1).SElected.FUNction.DOMain.STATe = True
    SCPI.CALCulate(1).SElected.FUNction.EXECute
    MaxValC = SCPI.CALCulate(1).SElected.FUNction.DATA

    SCPI.CALCulate(1).SElected.FUNction.DOMain.START = 6000000000#
    SCPI.CALCulate(1).SElected.FUNction.DOMain.STOP = 7500000000#
    SCPI.CALCulate(1).SElected.FUNction.DOMain.STATe = True
```

Performance Tests

5. CROSSTALK TEST

```
SCPI.CALCulate(1).SElected.FUNction.EXECute
MaxValD = SCPI.CALCulate(1).SElected.FUNction.DATA

SCPI.CALCulate(1).SElected.FUNction.DOMain.START = 7500000000#
SCPI.CALCulate(1).SElected.FUNction.DOMain.STOP = 8500000000#
SCPI.CALCulate(1).SElected.FUNction.DOMain.STAtE = True
SCPI.CALCulate(1).SElected.FUNction.EXECute
MaxValE = SCPI.CALCulate(1).SElected.FUNction.DATA

frmCrossTalk2.txtVal1.Text = CSng(20 * Log10(MaxValB(0)))
frmCrossTalk2.txtVal2.Text = CSng(20 * Log10(MaxValC(0)))
frmCrossTalk2.txtVal3.Text = CSng(20 * Log10(MaxValD(0)))
frmCrossTalk2.txtVal4.Text = CSng(20 * Log10(MaxValE(0)))
frmCrossTalk2.Show

End If

End Sub

Function Log10(X)

    Log10 = Log(X) / Log(10)

End Function
```

6. SYSTEM DYNAMIC RANGE TEST

Description

This test checks the system dynamic range for the receiver ports of the E5070A/E5071A. The system dynamic range is tested by performing an "Isolation" measurement 16 times with 101 sweep points for specified frequency ranges (after the response and isolation calibrations are performed) and calculating the RMS deviation value from the 16 measurement data for each sweep frequency point. The maximum RMS deviation value in each frequency range is extracted to determine the system dynamic range performance.

Specification

E5070A

- 95 dB @ 23 ± 5 °C, 3 MHz to 1.5 GHz, IFBW 3 kHz
- 97 dB @ 23 ± 5 °C, 1.5 GHz to 3 GHz, IFBW 3 kHz
- 120 dB @ 23 ± 5 °C, 3 MHz to 1.5 GHz, IFBW 10 Hz
- 122 dB @ 23 ± 5 °C, 1.5 GHz to 3 GHz, IFBW 10 Hz

E5071A

- 95 dB @ 23 ± 5 °C, 3 MHz to 1.5 GHz, IFBW 3 kHz
- 97 dB @ 23 ± 5 °C, 1.5 GHz to 4 GHz, IFBW 3 kHz
- 95 dB @ 23 ± 5 °C, 4 GHz to 6 GHz, IFBW 3 kHz
- 92 dB @ 23 ± 5 °C, 6 GHz to 7.5 GHz, IFBW 3 kHz
- 85 dB @ 23 ± 5 °C, 7.5 GHz to 8.5 GHz, IFBW 3 kHz
- 120 dB @ 23 ± 5 °C, 3 MHz to 1.5 GHz, IFBW 10 Hz
- 122 dB @ 23 ± 5 °C, 1.5 GHz to 4 GHz, IFBW 10 Hz
- 120 dB @ 23 ± 5 °C, 4 GHz to 6 GHz, IFBW 10 Hz
- 117 dB @ 23 ± 5 °C, 6 GHz to 7.5 GHz, IFBW 10 Hz
- 110 dB @ 23 ± 5 °C, 7.5 GHz to 8.5 GHz, IFBW 10 Hz

NOTE

The specification applies when the response and isolation calibration is performed and averaging factor is 16.

Test equipment

Coaxial cable with Type-N (m) connectors, 61 cm (24 in)	N6314A(p/n 8120-8862)
---	-----------------------

6. SYSTEM DYNAMIC RANGE TEST

Type-N(m) 50 Ω Load termination (2 ea.)	part of 85032F/54D /33E/50D with Type-N adapter
--	---

Procedure

Step 1. Connect a load termination to each test port as shown in the following figures:

Opt. 213/214: Figure 2-19

Opt. 313/314: Figure 2-20

Opt. 413/414: Figure 2-21

Figure 2-19 Isolation calibration setup for system dynamic range test (Opt. 213/214)

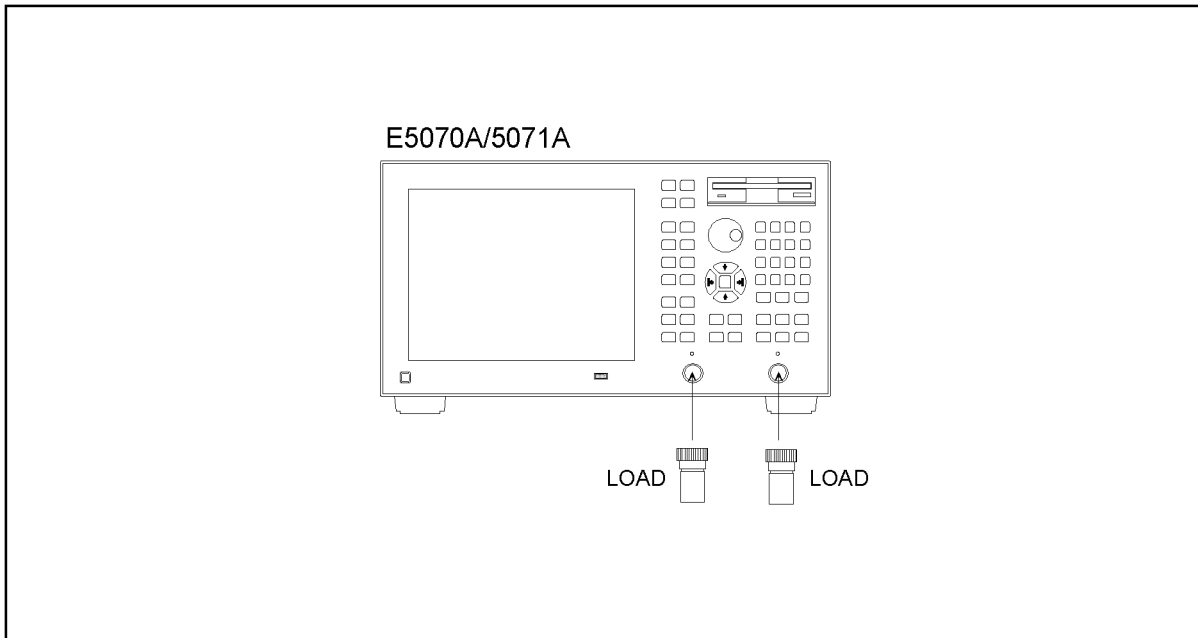

e5070ase020

Figure 2-20 Isolation calibration setup for system dynamic range test (Opt. 313/314)

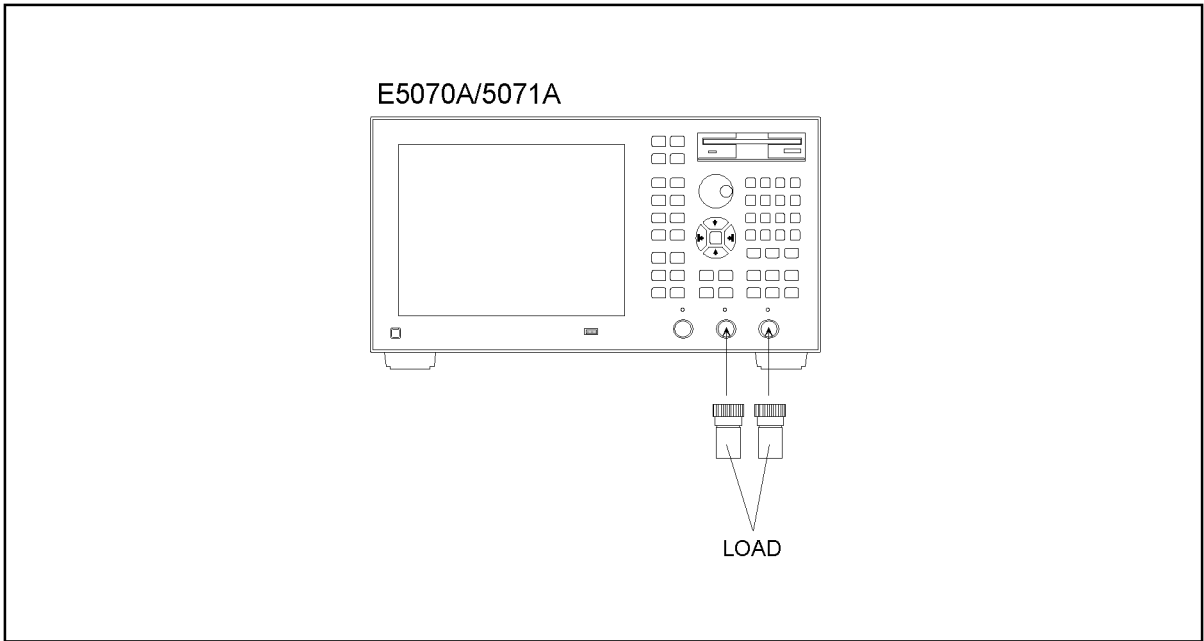

e5070ase284

Figure 2-21 Isolation calibration setup for system dynamic range test (Opt. 413/414)

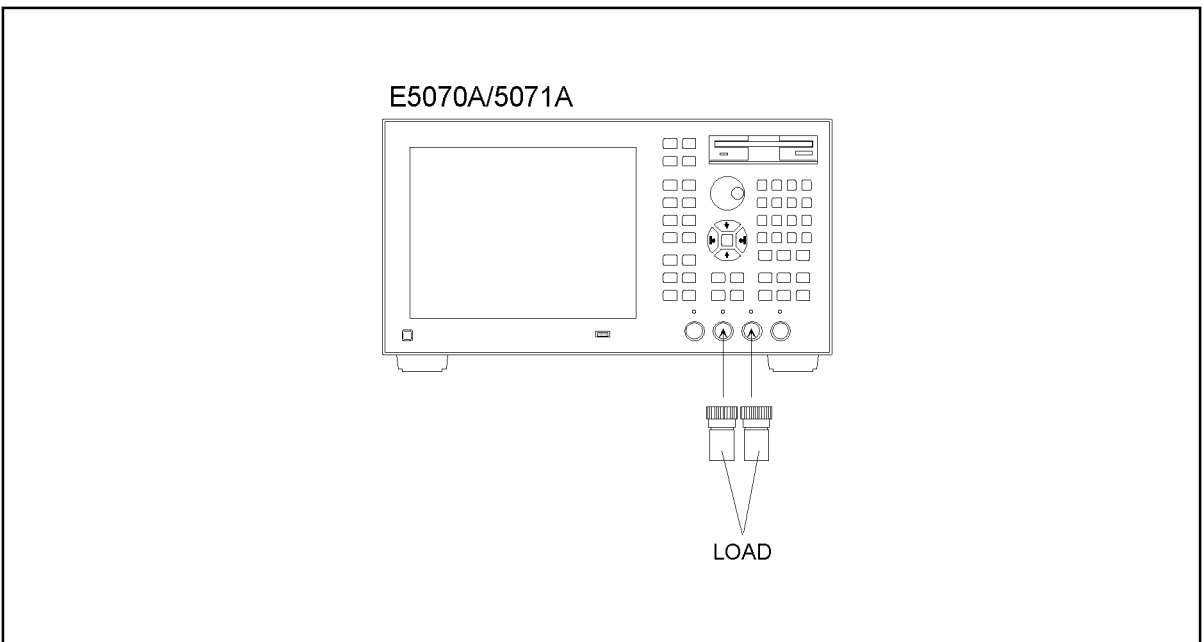

e5070ase286

- Step 2. Press **Preset** and **Enter** to initialize the E5070A/E5071A.
- Step 3. Press **Format** and select **Lin Mag** from display format menu.

Performance Tests
6. SYSTEM DYNAMIC RANGE TEST

Step 4. Set the controls as follows:

Control settings	Key strokes
IF Bandwidth: 10 Hz	<input type="button" value="Avg"/> - <input type="button" value="Enter"/> - <input type="button" value="1"/> - <input type="button" value="0"/> - <input type="button" value="x1"/>
Averaging: ON	<input type="button" value="↑"/> - <input type="button" value="↑"/> - <input type="button" value="↑"/> (select Averaging) - <input type="button" value="Enter"/>
Averaging factor now is set to 16 (preset value).	
Number of points: 101	<input type="button" value="Sweep Setup"/> - <input type="button" value="↓"/> - <input type="button" value="↓"/> - <input type="button" value="↓"/> - <input type="button" value="↓"/> - <input type="button" value="↓"/> (select Points) - <input type="button" value="Enter"/> - <input type="button" value="1"/> - <input type="button" value="0"/> - <input type="button" value="1"/> - <input type="button" value="x1"/>

The source power now is set to 0 dBm (preset value).

Response (Thru) calibration

Step 5. Press - - - - and to select **Cal Kit**.

Step 6. Press - - and to select **85032F**.

NOTE

If **Cal Kit** is set to **85032F***, press , , - - - - to select **Restore Cal Kit**.

Step 7. Press - and to select **Calibrate** function.

Step 8. Press - and to select **Response (Thru)** calibration.

Step 9. Press to go down to **Select Ports** menu.

Step 10. Select **2-1 (21)** for the option 213/214 instruments and **3-2 (S32)** for the option 313/314413/414 instruments as shown in the first row in Table 2-8.

Table 2-8

Select Ports settings for response calibration

	Option		
	213/214	313/314	413/414
1	2-1(S21)	3-2 (S32)	3-2 (S32)
2	1-2 (S12)	2-3 (S23)	2-3 (S23)
3	Not required	2-1 (S21)	4-1 (S41)
4	Not required	1-2 (S12)	1-4 (S14)

Step 11. Press - and to perform **Isolation** calibration.

Step 12. Disconnect the load and connect the N-N cable as shown in the following figures.

- Opt. 213/214: Figure 2-22
- Opt. 313/314: Figure 2-23
- Opt. 413/414: Figure 2-24

Figure 2-22 Thru calibration setup for system dynamic range test setup (Opt. 213/214)

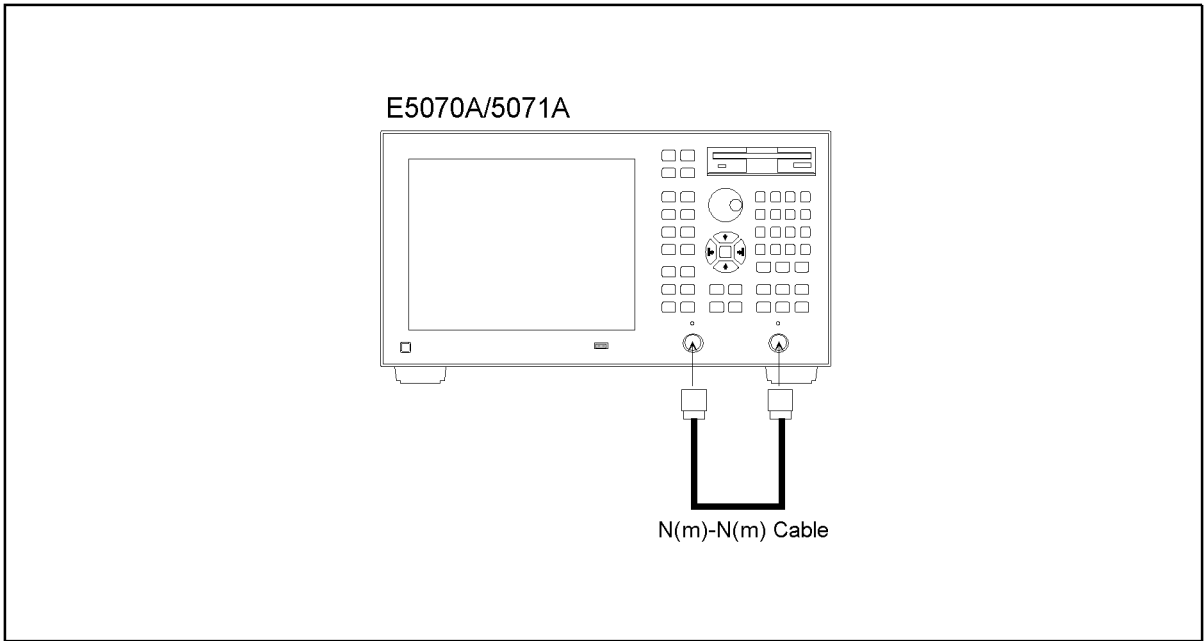

e5070ase010

Figure 2-23 Thru calibration setup for system dynamic range test setup (Opt. 313/314)

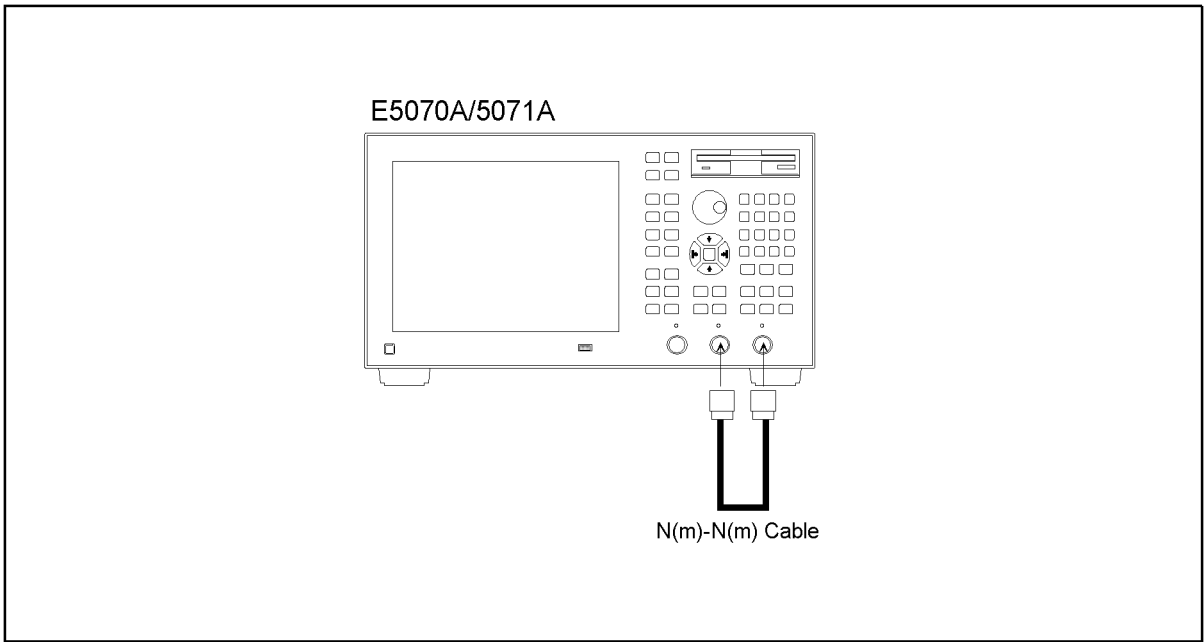

e5070ase012

Performance Tests
6. SYSTEM DYNAMIC RANGE TEST

Figure 2-24 Thru calibration setup for system dynamic range test setup (Opt. 413/414)

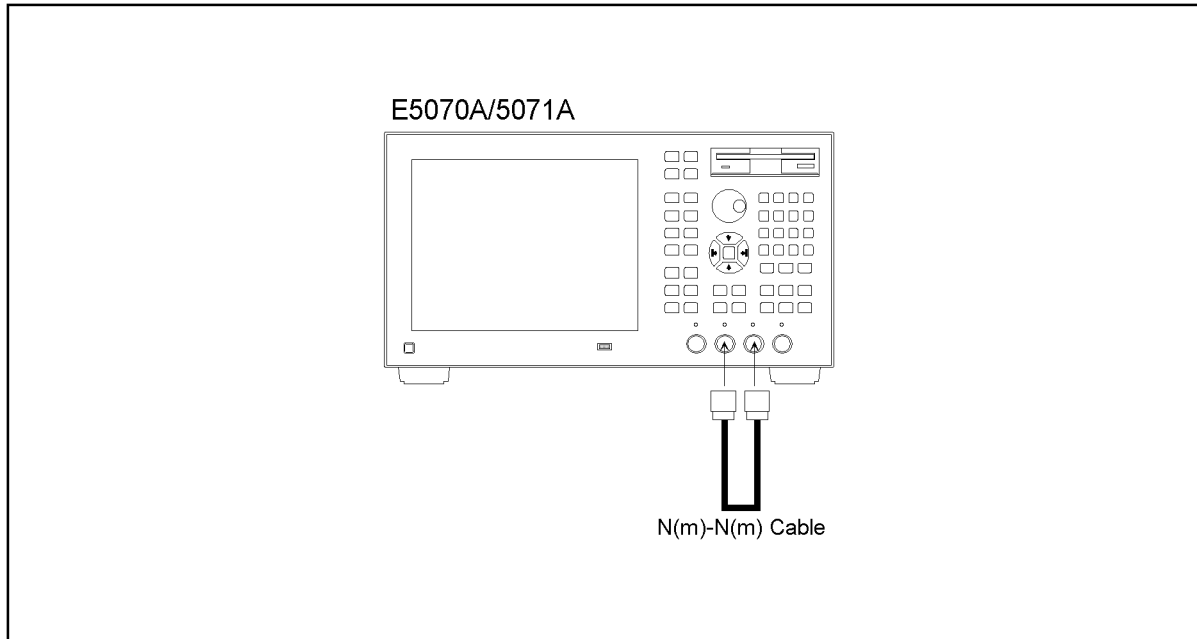

e5070ase018

NOTE To avoid possible variance in measured values, do not touch or move the N-N cable during measurements.

- Step 13.** Press and to perform **Thru** calibration.
- Step 14.** Press - - to perform **Done**.
- Step 15.** Press - - to select **Select Ports** (in reference to the position of **Done**) and press .
- Step 16.** Change **Select Ports** setting as shown in the second row in Table 2-8.
- Step 17.** Press - to perform **Thru** calibration.
- Step 18.** Disconnect the N-N cable and connect the Load termination to each test port as shown in the following figures.
- Opt. 213/214: Figure 2-19
 - Opt. 313/314: Figure 2-20
 - Opt. 413/414: Figure 2-21
- Step 19.** Press and to perform **Isolation** calibration.
- Step 20.** Press and to perform **Done**.
- System dynamic rang measurement for select ports setting as shown in the first and second row in** Table 2-8
- Step 21.** Press and verify that **Correction** is set to **ON**.

Step 22. Press **Avg** - **↑** - **↑** - **↑** (select **Averaging**) - **Enter** to set the **Averaging** function to OFF.

NOTE Be sure to set the **Averaging** function to OFF.

Step 23. Program or download the test program shown in Program 2-2.

NOTE Also set a UserForm window to enable the test result output data to be displayed. An example of the UserForm window is shown in Figure 2-25. Refer to the Agilent E5070A/E5071A VBA Programmer's Guide for the UserForm setup procedure.

Step 24. Press **Meas** and select the following S-parameter from menu:

Option 213/214: **S21**

Option 313/314/413/414: **S32**

These parameters are shown in the first row in Table 2-9.

Table 2-9 S-parameter settings for system dynamic range test

	Option		
	213/214	313/314	413/414
1	S21	S32	S32
2	S12	S23	S23
3	Not required	S21	S41
4	Not required	S12	S14

Step 25. Press **Macro Run** to run the test program. This test program repeats a swept measurement 16 times, calculates the RMS deviation from the 16 measurement values at each sweep frequency point, and extracts the maximum deviation value for each of the following frequency ranges:

E5070A: 3 MHz to 1.5 GHz and 1.5 GHz to 3 GHz (2 ranges)

E5071A: 3 MHz to 1.5 GHz, 1.5 GHz to 4 GHz, 4 GHz to 6 GHz, 6 GHz to 7.5 GHz and 7.5 GHz to 8 GHz (5 ranges)

The maximum deviation value in each frequency range is represented in dB and displayed in the VBA UserForm window as shown in the display example below.

Performance Tests
6. SYSTEM DYNAMIC RANGE TEST

Figure 2-25 VBA UserForm window display example

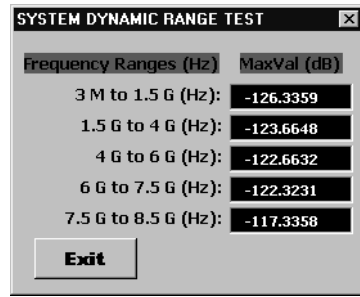

Step 26. Record the maximum RMS deviation values in the performance test record ("Test result [dB]" column for the system dynamic range test).

Step 27. Press **Exit** button on the SYSTEM DYNAMIC RANG TEST window.

Step 28. Press **Avg** - **Enter** - **3** - **k/m** to change the **IF Bandwidth** setting to 3 kHz and perform Step 25 through 27.

Step 29. Press **Avg** - **Enter** - **1** - **0** - **x1** to change the **IF Bandwidth** setting to 10 Hz , change the S-parameter setting as shown in the second row in Table 2-9 and perform Step 25 through 28.

Step 30. For the option 313/314/413/414, proceed to Step 31.

Response (Thru) calibration for options 313, 314, 413 and 414 only

Step 31. Connect the Load termination to each test port as shown in Figure 2-26 (Opt. 313/314) and Figure 2-27 (Opt. 413/414).

Figure 2-26 Isolation calibration setup for system dynamic range test (Opt. 313/314)

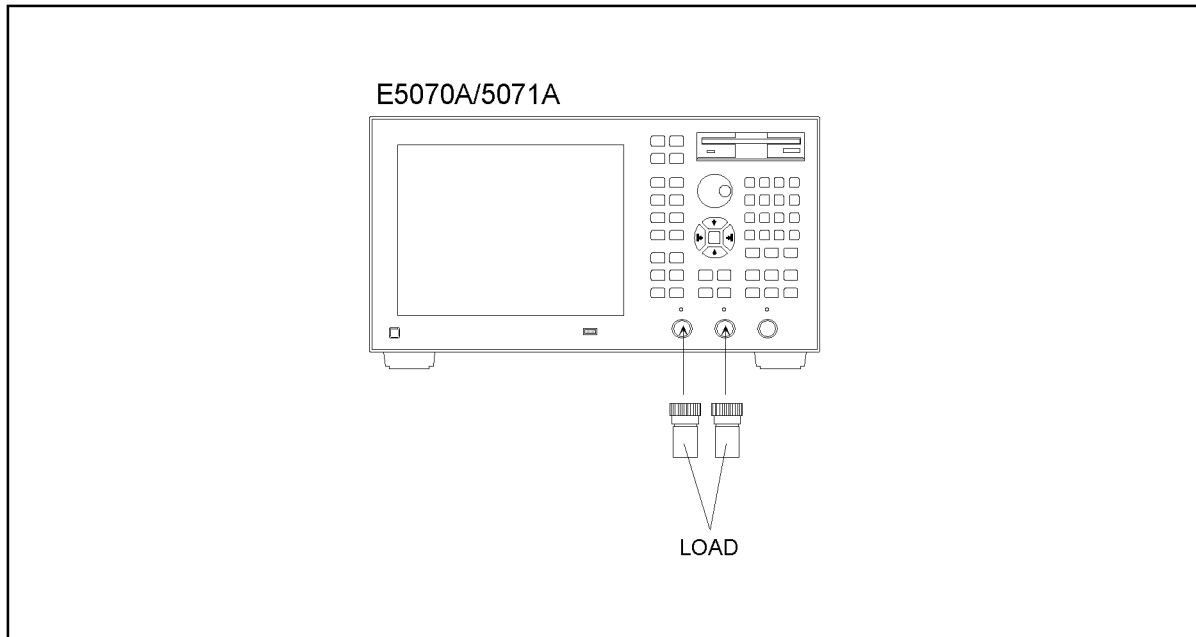

e5070ase285

Figure 2-27 Isolation calibration setup for system dynamic range test (Opt. 413/414)

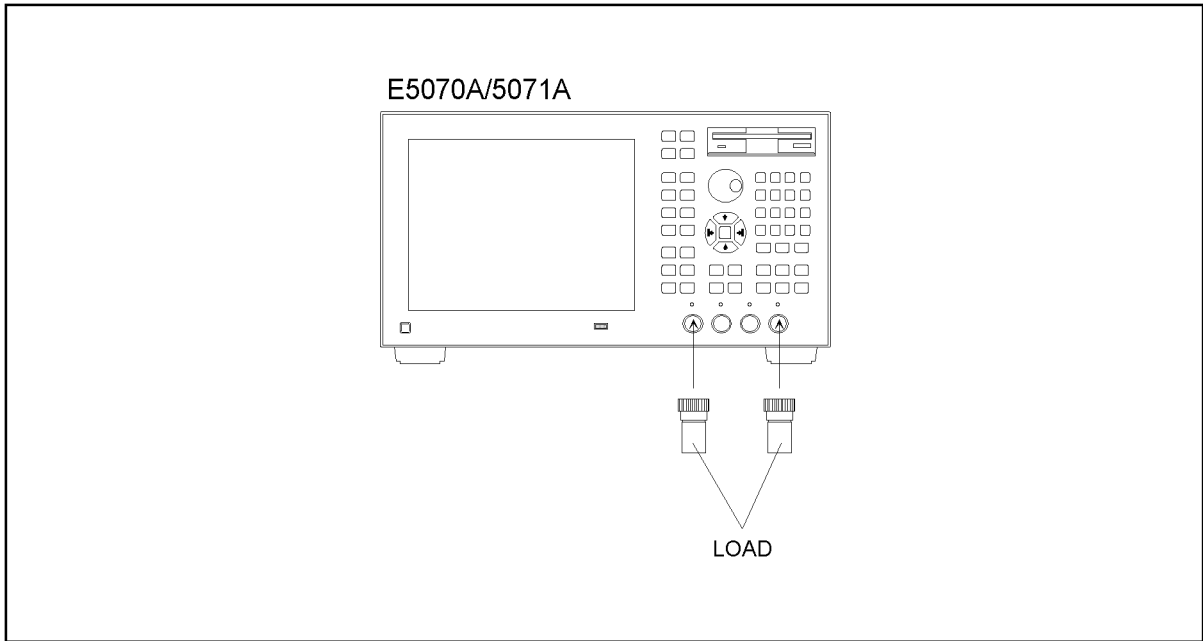

e5070ase287

2. Performance Test

Step 32. Set the controls as follows:

Control settings	Key strokes
IF Bandwidth: 10 Hz	<input type="button" value="Avg"/> - <input type="button" value="Enter"/> - <input type="button" value="1"/> - <input type="button" value="0"/> - <input type="button" value="x1"/>
Averaging: ON	<input type="button" value="↑"/> - <input type="button" value="↑"/> - <input type="button" value="↑"/> (select Averaging) - <input type="button" value="Enter"/>
Averaging factor now is set to 16 (preset value).	

Step 33. Press - and to select **Calibrate** function.

Step 34. Press - and to select **Response (Thru)** calibration.

Step 35. Press to go down to **Select Ports** menu.

Step 36. Select **2-1 (21)** for the option 313/314 instruments and **4-1 (S41)** for the option 413/414 instruments as shown in the third row in Table 2-10.

Table 2-10

Select Ports settings for response calibration

	Option		
	213/214	313/314	413/414
1	2-1(S21)	3-2 (S32)	3-2 (S32)
2	1-2 (S12)	2-3 (S23)	2-3 (S23)
3	Not required	2-1 (S21)	4-1 (S41)

6. SYSTEM DYNAMIC RANGE TEST

Table 2-10 **Select Ports settings for response calibration**

	Option		
	213/214	313/314	413/414
4	Not required	1-2 (S12)	1-4 (S14)

Step 37. Press  -  and  to perform **Isolation** calibration.

Step 38. Disconnect the load and connect the N-N cable as shown in the following figures.

Opt. 313/314: Figure 2-28

Opt. 413/414: Figure 2-29

Figure 2-28 **Thru calibration setup for system dynamic range test setup (Opt. 313/314)**

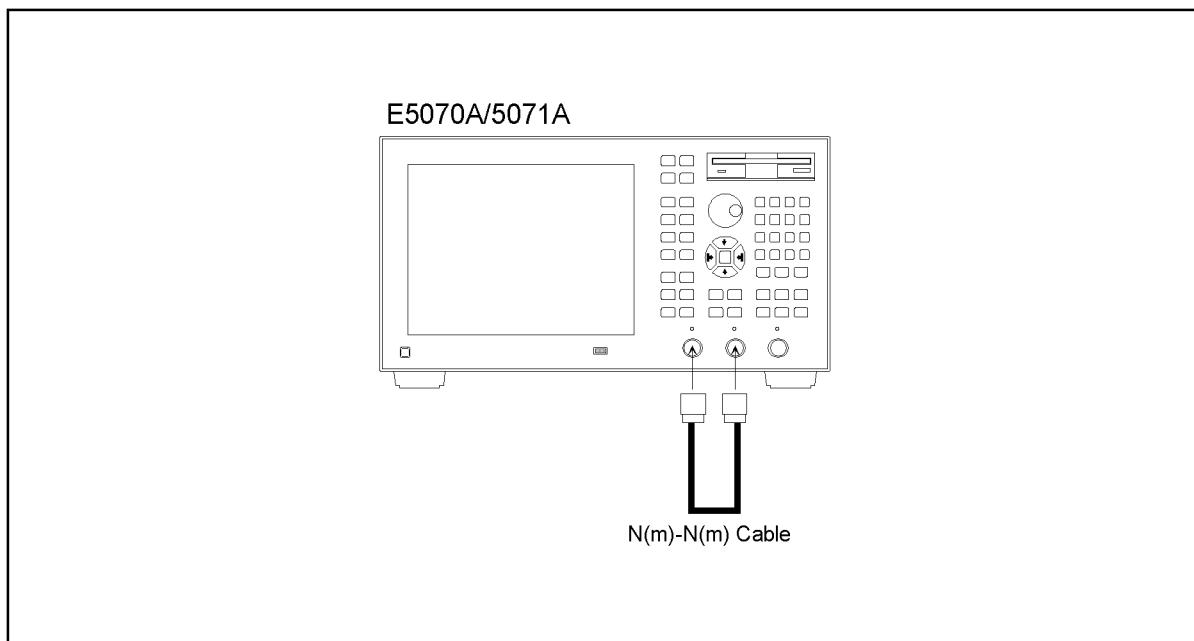

e5070ase011

Figure 2-29 Thru calibration setup for system dynamic range test setup (Opt. 413/414)

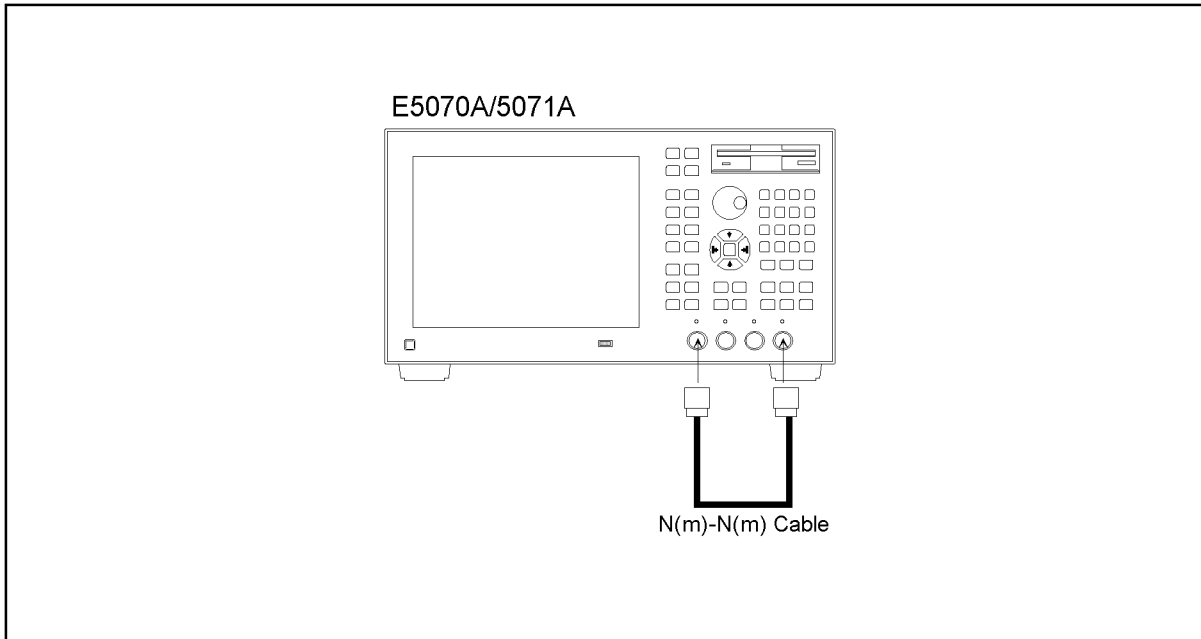

e5070ase017

- Step 39.** Press and to perform **Thru** calibration.
 - Step 40.** Press - - to perform **Done**.
 - Step 41.** Press - - to select **Select Ports** (in reference to the position of **Done**) and press .
 - Step 42.** Change **Select Ports** setting as shown in the fourth row in Table 2-10.
 - Step 43.** Press - to perform **Thru** calibration.
 - Step 44.** Disconnect the N-N cable and connect the Load termination to each test port as shown in the following figures.
 - Opt. 313/314: Figure 2-26
 - Opt. 413/414: Figure 2-27
 - Step 45.** Press and to perform **Isolation** calibration.
 - Step 46.** Press and to perform **Done**.
- System dynamic rang measurement for select ports setting as shown in the third and fourth row in Table 2-10**
- Step 47.** Press and verify that **Correction** is set to **ON**.
 - Step 48.** Press - - - (select **Averaging**) - to set the **Averaging** function to OFF.

NOTE Be sure to set the **Avaraging** function to OFF.

Performance Tests
6. SYSTEM DYNAMIC RANGE TEST

- Step 49.** Press **Meas** and select the following S-parameter from menu:
 Option 313/314: **S21**
 Option 413/414: **S41**

These parameters are shown in the third row in Table 2-11.

Table 2-11 S-parameter settings for system dynamic range test

	Option		
	213/214	313/314	413/414
1	S21	S32	S32
2	S12	S23	S23
3	Not required	S21	S41
4	Not required	S12	S14

- Step 50.** Press **Macro Run** to run the test program.

Figure 2-30 VBA UserForm window display example

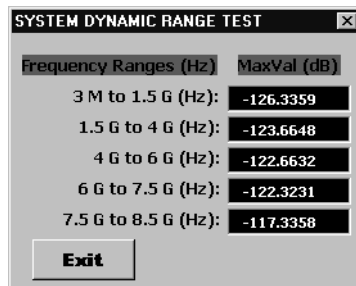

- Step 51.** Record the maximum RMS deviation values in the performance test record ("Test result [dB]" column for the system dynamic range test).
- Step 52.** Press **Exit** button on the SYSTEM DYNAMIC RANGE TEST window.
- Step 53.** Press **Avg** - **Enter** - **3** - **k/m** to change the **IF Bandwidth** setting to 3 kHz and perform Step 50 through 52.
- Step 54.** Press **Avg** - **Enter** - **1** - **0** - **x1** to change the **IF Bandwidth** setting to 10 Hz , change the S-parameter setting as shown in the fourth row in Table 2-11 and perform Step 50 through 53.

System Dynamic Range test program

Coding procedure:

- Step 1.** Press **Macro Setup** key.
- Step 2.** Press **Enter** to activate **VBA Editor** function.
- Step 3.** Click **Insert** and select **Module** from pull-down menu. VBA Project - Module1 [Code]

window screen for coding a program will be displayed.

Step 4. Input the test program shown below.

Step 5. Save the test program with a proper file name.

Program 2-2

Test program:

```

Sub Main()

    Dim Val(15) As Variant, X(201) As Double, Y(201) As Double, Rms As Variant
    Dim I As Integer, J As Integer, K As Integer, Dmy As Long
    Dim Ver As String
    Dim MaxValA As Variant, MaxValB As Variant
    Dim MaxValC As Variant, MaxValD As Variant, MaxValE As Variant,
    MaxValF As Variant, MaxValG As Variant

    SCPI.TRIGger.SEQuence.Source = "BUS"
    SCPI.INITiate(1).CONTinuous = True

    For I = 0 To 15
        SCPI.TRIGger.SEQuence.SINGLE
        Dmy = SCPI.IEEE4882.OPC
        SCPI.CALCulate(1).PARAmeter(1).SElect
        Val(I) = SCPI.CALCulate(1).SElected.DATA.FDATA
    Next I

    For J = 0 To 201
        X(J) = Val(0)(J) ^ 2
    Next J

    For J = 0 To 201
        For I = 1 To 15
            X(J) = X(J) + Val(I)(J) ^ 2
        Next I
        Y(J) = Sqr(X(J) / 16)
    Next J

    Rms = CVar(Y)
    SCPI.CALCulate(1).SElected.DATA.FDATA = Rms

```

6. SYSTEM DYNAMIC RANGE TEST

```
SCPI.TRIGger.SEQuence.SINGle
```

```
Dmy = SCPI.IEEE4882.OPC
```

```
Ver = Name
```

```
If Ver = "E5070A" Then
```

```
    SCPI.CALCulate(1).PARAmeter(1).SElect
```

```
    SCPI.CALCulate(1).SElected.Function.TYPE = "MAX"
```

```
    SCPI.CALCulate(1).SElected.Function.DOMain.START = 3000000#
```

```
    SCPI.CALCulate(1).SElected.Function.DOMain.STOP = 1500000000#
```

```
    SCPI.CALCulate(1).SElected.Function.DOMain.STATe = True
```

```
    SCPI.CALCulate(1).SElected.Function.EXECute
```

```
    MaxValA = SCPI.CALCulate(1).SElected.Function.DATA
```

```
    SCPI.CALCulate(1).SElected.Function.DOMain.START = 1500000000#
```

```
    SCPI.CALCulate(1).SElected.Function.DOMain.STOP = 3000000000#
```

```
    SCPI.CALCulate(1).SElected.Function.DOMain.STATe = True
```

```
    SCPI.CALCulate(1).SElected.Function.EXECute
```

```
    MaxValB = SCPI.CALCulate(1).SElected.Function.DATA
```

```
    frmDynamicRange1.txtVal1.Text = CSng(20 * Log10(MaxValA(0)))
```

```
    frmDynamicRange1.txtVal2.Text = CSng(20 * Log10(MaxValB(0)))
```

```
    frmDynamicRange1.Show
```

```
ElseIf Ver = "E5071A" Then
```

```
    SCPI.CALCulate(1).PARAmeter(1).SElect
```

```
    SCPI.CALCulate(1).SElected.Function.TYPE = "MAX"
```

```
    SCPI.CALCulate(1).SElected.Function.DOMain.START = 3000000#
```

```
    SCPI.CALCulate(1).SElected.Function.DOMain.STOP = 1500000000#
```

```
    SCPI.CALCulate(1).SElected.Function.DOMain.STATe = True
```

```
    SCPI.CALCulate(1).SElected.Function.EXECute
```

```
    MaxValC = SCPI.CALCulate(1).SElected.Function.DATA
```

```
    SCPI.CALCulate(1).SElected.Function.DOMain.START = 1500000000#
```

```
    SCPI.CALCulate(1).SElected.Function.DOMain.STOP = 4000000000#
```

```
    SCPI.CALCulate(1).SElected.Function.DOMain.STATe = True
```

```
    SCPI.CALCulate(1).SElected.Function.EXECute
```

```
    MaxValD = SCPI.CALCulate(1).SElected.Function.DATA
```

6. SYSTEM DYNAMIC RANGE TEST

```

SCPI.CALCulate(1).SElected.Function.DOMain.START = 4000000000#
SCPI.CALCulate(1).SElected.Function.DOMain.STOP = 6000000000#
SCPI.CALCulate(1).SElected.Function.DOMain.STATe = True
SCPI.CALCulate(1).SElected.Function.EXECute
MaxValE = SCPI.CALCulate(1).SElected.Function.DATA

```

```

SCPI.CALCulate(1).SElected.Function.DOMain.START = 6000000000#
SCPI.CALCulate(1).SElected.Function.DOMain.STOP = 7500000000#
SCPI.CALCulate(1).SElected.Function.DOMain.STATe = True
SCPI.CALCulate(1).SElected.Function.EXECute
MaxValF = SCPI.CALCulate(1).SElected.Function.DATA

```

```

SCPI.CALCulate(1).SElected.Function.DOMain.START = 7500000000#
SCPI.CALCulate(1).SElected.Function.DOMain.STOP = 8500000000#
SCPI.CALCulate(1).SElected.Function.DOMain.STATe = True
SCPI.CALCulate(1).SElected.Function.EXECute
MaxValG = SCPI.CALCulate(1).SElected.Function.DATA

```

```

frmDynamicRange2.txtVal1.Text = CSng(20 * Log10(MaxValC(0)))
frmDynamicRange2.txtVal2.Text = CSng(20 * Log10(MaxValD(0)))
frmDynamicRange2.txtVal3.Text = CSng(20 * Log10(MaxValE(0)))
frmDynamicRange2.txtVal4.Text = CSng(20 * Log10(MaxValF(0)))
frmDynamicRange2.txtVal5.Text = CSng(20 * Log10(MaxValG(0)))
frmDynamicRange2.Show

```

```
End If
```

```
End Sub
```

```
Function Log10(X)
```

```
Log10 = Log(X) / Log(10)
```

```
End Function
```

7. DYNAMIC ACCURACY TEST

Description

This test checks the dynamic accuracy of the E5070A/E5071A. The dynamic accuracy is tested at 1.195 GHz for each receiver port using the Agilent Z5623A (with option H01) Dynamic Accuracy Test Kit. A block diagram of the Z5623A is shown in Figure 2-31. The 1.195 GHz source signal of the E5070A/E5071A goes through the Z5623A's first attenuator variable from 0 dB to 11 dB in 1 dB steps and second attenuator variable up to 100 dB in 10 dB steps and is measured with the receiver port. The test procedure checks the measured receiver-input power for each 5 dB increment in the range from 0 dBm to 110 dBm. The ratios of the measured receiver-input powers to the reference input level of -20 dBm are calculated and compared to the attenuation values of the Z5623A. The 1.195 GHz signal flow is split with a power splitter present between the two attenuators in the Z5623A and measured with an external power meter to calibrate the attenuated power level.

NOTE Since the dynamic accuracy does not have frequency dependence, this test is performed at 1.195 GHz only.

Table 2-12 Dynamic accuracy specification: @ 23° ± 5°C

Input level (dBm)	Dynamic accuracy (dB)	Input level (dBm)	Dynamic accuracy (dB)
0	0.207	-60	0.091
-5	0.075	-65	0.106
-10	0.042	-70	0.125
-15	0.031	-75	0.151
-20	0.024	-80	0.189
-25	0.030	-85	0.248
-30	0.035	-90	0.346
-35	0.040	-95	0.509
-40	0.045	-100	0.785
-45	0.056	-105	1.248
-50	0.067	-110	2.008
-55	0.078		

Test Equipment

Power meter	Agilent E4419A/B
-------------	------------------

Power sensor	Agilent 8482A
Dynamic Accuracy Test Kit	Agilent Z5623A w/Opt. H01
6 dB fixed attenuator	Agilent 8491A w/Opt. 006 and H60
Coaxial cable with N-type (m) connectors, 61 cm (24 in), 2 ea.	Agilent N6314A (p/n 8120-8862)
GPIB controller (or PC with GPIB Interface Card)	
GPIB Interconnection Cable	Agilent 10833A/B

Procedure

- Step 1.** Connect the power sensor to the power meter. Calibrate the power meter for the power sensor used.
- Step 2.** Connect the test equipment as shown in the following figures:

- Option 213/214: Figure 2-32
- Option 313/314: Figure 2-33
- Option 413/414: Figure 2-34

Figure 2-31 Agilent Z5623A block diagram

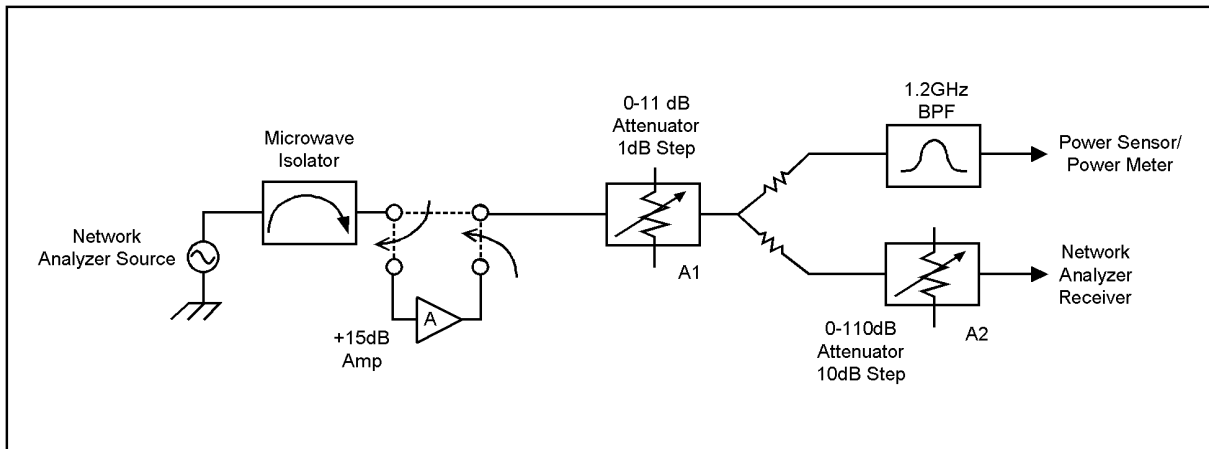

e5070ase045

Performance Tests
7. DYNAMIC ACCURACY TEST

Figure 2-32 Dynamic accuracy test setup (Opt. 213/214)

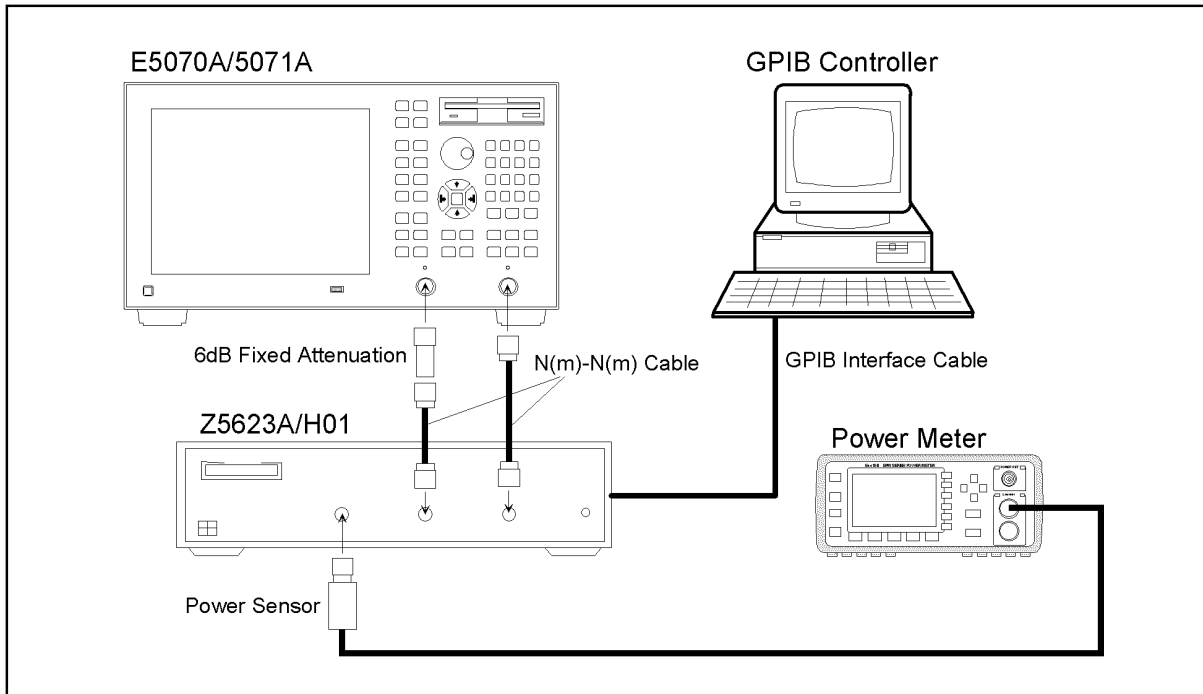

e5070ase023

Figure 2-33 Dynamic accuracy test setup (Opt. 313/314)

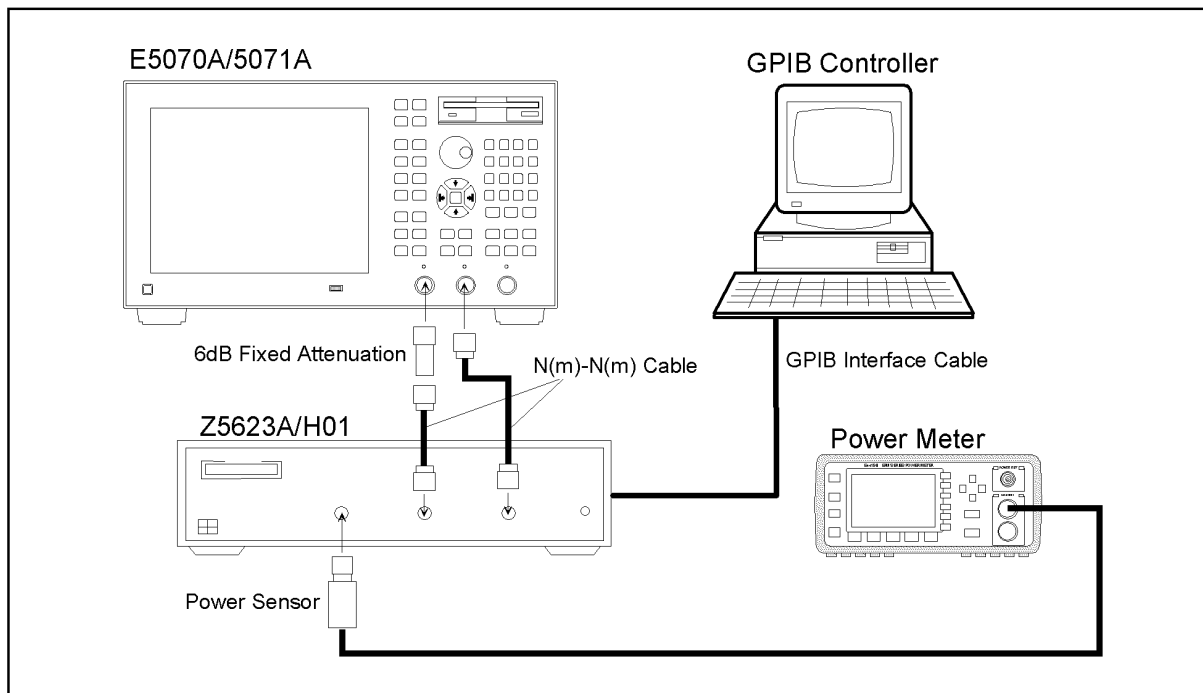

e5070ase025

Figure 2-34 Dynamic accuracy test setup (Opt. 413/414)

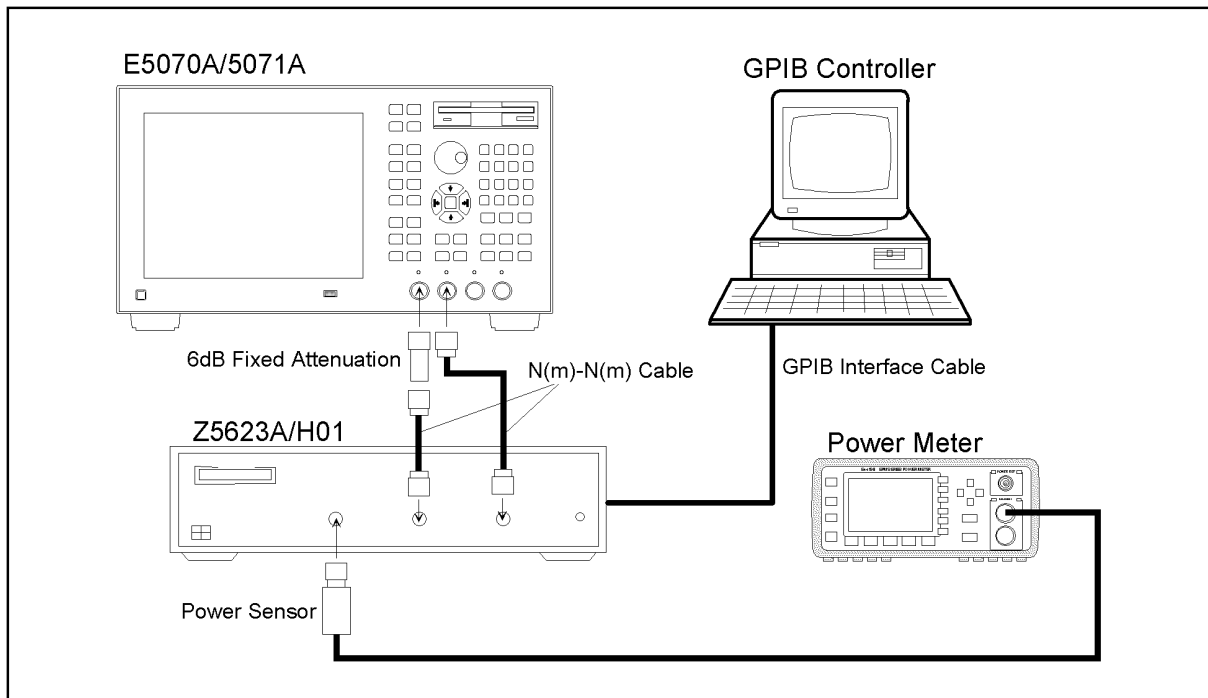

e5070ase028

2. Performance Test

NOTE To avoid possible variance in measured values, do not touch or move the N-N cable during measurements.

NOTE Do not touch the power sensor during measurements.

Power meter zero adjustment

NOTE This adjustment is required to subtract residual noise power of the Z5623A from the subsequent signal power measurements.

Step 3. Set the first attenuator (A1) of the Z5623A to 11 dB and the second attenuator (A2) to 110 dB by executing the following GPIB control command:

```
GPIB:
    OUTPUT 712; "amp_in"
    OUTPUT 712; "at_a=11"
    OUTPUT 712; "at_b=110"
```

Step 4. Press **[Preset]** and **[Enter]** to initialize the E5070A/E5071A.

Step 5. Set the controls as follows:

Control settings	Key strokes
Center frequency: 50 MHz	[Center] - [5] - [0] - [M/μ]

Performance Tests
7. DYNAMIC ACCURACY TEST

Control settings	Key strokes
Frequency span: 0 Hz	Span - 0 - x1
IF Bandwidth: 10 Hz	Avg - Enter - 1 - 0 - x1
Source power: -15 dBm	Sweep Setup - +/- - 1 - 5 - x1

Step 6. Wait for the power meter reading to settle and perform zero adjustment of the power meter.

Dynamic accuracy tests at -20 dBm to -110dBm

Step 7. Press **Format** and select **Log Mag** from display format menu.

Step 8. Set the controls as follows:

Control settings	Key strokes
Center frequency: 1.195 GHz	Center - 1 - . - 1 - 9 - 5 - G/n
Frequency span: 0 Hz	Span - 0 - x1
Number of points: 15	Sweep Setup - ↓ - ↓ - ↓ - ↓ - ↓ (select Points) - Enter - 1 - 5 - x1

Step 9. Press **Marker Fctn** - **↓** - **↓** - **↓** - **↓** - **↓** - **↓** - **↓** - **↓** - **Enter** to set **Statistics** function to ON.

Step 10. Press **Meas** and select **S21** from S-parameter menu.

Step 11. Set the first attenuator (A1) of the Z5623A to 0 dB and the second attenuator (A2) to 20 dB by executing the following GPIB control command:

GPIB:
 OUTPUT 712; "amp_in"
 OUTPUT 712; "at_a=0"
 OUTPUT 712; "at_b=20"

Step 12. Adjust the source power for 0 dBm on the power meter display. Wait for power meter reading to settle when verifying the adjustment result.

NOTE Since the source power resolution is 0.05 dB, adjust for the nearest possible value to 0 dBm.

Step 13. Press **Trigger** - **↓** - **Enter** to make a **Single** sweep measurement.

Step 14. Record the value of the source power setting in the calculation sheet ("Power setting [dB]" column for the dynamic accuracy test). The record starts from DA20 row.

Step 15. Record the power meter reading in the calculation sheet ("Pm [dB]" column).

Step 16. Read the mean value of the S21 displayed in the upper left corner of the graphic display

and record it in the calculation sheet ("Sxy [dB]" column)

- Step 17.** Set **Port Char** function to **OFF** in accordance with the following procedure:
- Press **System** - - - - - - - - - (select **Service Menu**), **Enter**.
 - Press - - - - (select **Service Functions**), **Enter**.
 - The E5070A/E5071A will once prompt you a password entry for the access to the **Service Functions**. Enter the password: **kid**
 - Press - - (select **System Calibration**), **Enter**.
 - Press - - (select **Port Char**), **Enter** to set the **Port Char** to **OFF**.
- Step 18.** Perform **Return** and press - (select **Measure (SVC)**), **Enter**.
- Step 19.** Select **R** from the **Measure (SVC)** menu.
- Step 20.** Press **Trigger** - - **Enter** to make a **Single** sweep measurement.
- Step 21.** Read the mean value of the R(S21) displayed in the upper left corner of the graphic display and record it in the calculation sheet ("R [dB]" column).
- Step 22.** Calculate Sxy (dB) + R (dB) and record the result in the calculation sheet ("Sxy × R [dB]" column).

NOTE

The Sxy (dB) + R (dB) corresponds to calculating Sxy × R in linear expression.
It represents the receiver port input power.

- Step 23.** Select **OFF** from the **Measure (SVC)** menu.

NOTE

Be sure to set the **Measure (SVC)** function to OFF.

- Step 24.** Set **Port Char** function to **ON** as follows:

- Press - - (select **System Calibration**), **Enter**.
- Press - - (select **Port Char**), **Enter**.

NOTE

Be sure to set the **Port Char** to ON.

- Step 25.** Set the first attenuator (A1) of the Z5623A to 5 dB by executing the following GPIB control command:

GPIB:
 OUTPUT 712; "amp_in"
 OUTPUT 712; "at_a=5"
 OUTPUT 712; "at_b=20"

The total attenuation for the A1 and A2 attenuators is 25 dB.

- Step 26.** Perform Step 13 through 24.

7. DYNAMIC ACCURACY TEST

Step 27. Calculate the dynamic accuracy for -25 dBm using the following equation:

$$\text{D.A.} = (\text{Sxy} \times \text{R@ DA25}) - (\text{Sxy} \times \text{R @ DA20}) - (\text{Pm @ DA25}) + (\text{Pm @ DA20})$$

NOTE

The records for -20 dBm are used as the reference values in the dynamic accuracy calculation.

Step 28. Record the calculated value in the calculation sheet ("Running D.A. [dB]" column for DA25).

Step 29. Record the same value in the "True D.A. [dB]" column in the calculation sheet.

Step 30. Set the first attenuator (A1) of the Z5623A to 10 dB by executing the following GPIB control command:

GPIB:

```
OUTPUT 712; "amp_in"
OUTPUT 712; "at_a=10"
OUTPUT 712; "at_b=20"
```

The total attenuation for the A1 and A2 attenuators is 30 dB.

Step 31. Perform Step 13 through 24.

Step 32. Calculate the dynamic accuracy for -30 dBm using the following equation:

$$\text{D.A.} = (\text{Sxy} \times \text{R @ DA30}) - (\text{Sxy} \times \text{R @ DA20}) - (\text{Pm @ DA30}) + (\text{Pm @ DA20})$$

Step 33. Record the calculated value in the calculation sheet ("Running D.A. [dB]" and "True D.A. [dB]" columns for DA30).

Step 34. Set the first attenuator (A1) of the Z5623A to 0 dB and the second attenuator (A2) to 30 dB by executing the following GPIB control command:

GPIB:

```
OUTPUT 712; "amp_in"
OUTPUT 712; "at_a=0"
OUTPUT 712; "at_b=30"
```

NOTE

This attenuator state is named DA30a. The following steps 35 through 37 are performed to equalize the receiver port input levels for the DA30 and DA30a.

Step 35. Perform Step 13 through 24.

Step 36. Calculate the difference in $\text{Sxy} \times \text{R}$ [dB] values for the DA30 and DA30a by using the following equation:

$$\Delta (\text{Sxy} \times \text{R [dB]}) = (\text{Sxy} \times \text{R [dB] @ DA30a}) - (\text{Sxy} \times \text{R [dB] @ DA30})$$

Step 37. Adjust the source power for the following value on the power meter display.

$$\text{Target value} = (\text{Pm [db] @ DA30a}) - \Delta (\text{Sxy} \times \text{R [dB]})$$

NOTE

It will be possible to promptly approximate the source power to the target value by decreasing the source power setting by $\Delta (\text{Sxy} \times \text{R})$ from that for the DA30.

NOTE After this adjustment is performed, the state is named DA30b.

Step 38. Perform Step 13 through 24.

Step 39. Set the first attenuator (A1) of the Z5623A to 5 dB by executing the following GPIB control command:

GPIB:

```
OUTPUT 712; "amp_in"
OUTPUT 712; "at_a=5"
OUTPUT 712; "at_b=30"
```

Step 40. Perform Step 13 through 24.

Step 41. Calculate the dynamic accuracy for -35 dBm using the following equation:

$$\text{D.A.} = (\text{Sxy} \times \text{R @ DA35}) - (\text{Sxy} \times \text{R @ DA30b}) - (\text{Pm @ DA35}) + (\text{Pm @ DA30b})$$

Step 42. Record the calculated D.A. in the calculation sheet ("Running D.A. [dB]" column for DA35).

Step 43. Calculate the true dynamic accuracy using the following equation:

$$\text{True D.A.} = (\text{Running D.A. [dB] @ DA35}) + (\text{True D.A. [dB] @ DA30})$$

NOTE When the A2 decade attenuator setting is increased from X dB to X+10 dB, calculate the True D.A. value as follows:

$$\text{True D.A. (X+10)} = \text{Running D.A. (X+10)} + \text{True D.A. (X)}$$

Where True D.A. (X+10): True D.A. value when A2=X+10 dB,

Running D.A. (X+10): Running D.A. value when A2=X+10 dB

True D.A. (X): True D.A. value when A1=10 dB and A2=X dB

Step 44. Record the true D.A. in the calculation sheet ("True D.A." column for DA35).

Step 45. Set the first attenuator (A1) of the Z5623A to 10 dB by executing the following GPIB control command:

GPIB:

```
OUTPUT 712; "amp_in"
OUTPUT 712; "at_a=10"
OUTPUT 712; "at_b=30"
```

Step 46. Perform Step 13 through 24.

Step 47. Calculate the dynamic accuracy for -40 dBm using the following equation:

$$\text{D.A.} = (\text{Sxy} \times \text{R @ DA40}) - (\text{Sxy} \times \text{R @ DA30b}) - (\text{Pm @ DA40}) + (\text{Pm @ DA30b})$$

Step 48. Record the calculated D.A. in the calculation sheet ("Running D.A. [dB]" column for DA40).

Step 49. Calculate the true dynamic accuracy using the following equation:

Performance Tests

7. DYNAMIC ACCURACY TEST

True D.A. = (Running D.A. [dB] @ DA40) + (True D.A. [dB] @ DA30)

Step 50. Record the true D.A. in the calculation sheet ("True D.A." column for DA40).

Step 51. Subsequently perform Step 34 through 50 for the attenuator settings of 45 dB to 110 dB (DA40a to DA110) shown in Table 2-13.

Table 2-13

Z5623A attenuator settings

	A1 setting [dB]	A2 setting [dB]	GPIB command
DA20	0	20	OUTPUT 712; "amp_in" OUTPUT 712; "at_a=0" OUTPUT 712; "at_b=0"
DA25	5	20	OUTPUT 712; "amp_in" OUTPUT 712; "at_a=5" OUTPUT 712; "at_b=20"
DA30	10	20	OUTPUT 712; "amp_in" OUTPUT 712; "at_a=10" OUTPUT 712; "at_b=20"
DA30a	0	30	OUTPUT 712; "amp_in" OUTPUT 712; "at_a=0" OUTPUT 712; "at_b=30"
DA35	5	30	OUTPUT 712; "amp_in" OUTPUT 712; "at_a=5" OUTPUT 712; "at_b=30"
DA40	10	30	OUTPUT 712; "amp_in" OUTPUT 712; "at_a=10" OUTPUT 712; "at_b=30"
DA40a	0	40	OUTPUT 712; "amp_in" OUTPUT 712; "at_a=0" OUTPUT 712; "at_b=40"
DA45	5	40	OUTPUT 712; "amp_in" OUTPUT 712; "at_a=5" OUTPUT 712; "at_b=40"
DA50	10	40	OUTPUT 712; "amp_in" OUTPUT 712; "at_a=10" OUTPUT 712; "at_b=40"
DA50a	0	50	OUTPUT 712; "amp_in" OUTPUT 712; "at_a=0" OUTPUT 712; "at_b=50"
DA55	5	50	OUTPUT 712; "amp_in" OUTPUT 712; "at_a=5" OUTPUT 712; "at_b=50"
DA60	10	50	OUTPUT 712; "amp_in" OUTPUT 712; "at_a=10" OUTPUT 712; "at_b=50"

Table 2-13

Z5623A attenuator settings

	A1 setting [dB]	A2 setting [dB]	 GPIB command
DA60a	0	60	OUTPUT 712; "amp_in" OUTPUT 712; "at_a=0" OUTPUT 712; "at_b=60"
DA65	5	60	OUTPUT 712; "amp_in" OUTPUT 712; "at_a=5" OUTPUT 712; "at_b=60"
DA70	10	60	OUTPUT 712; "amp_in" OUTPUT 712; "at_a=10" OUTPUT 712; "at_b=60"
DA70a	0	70	OUTPUT 712; "amp_in" OUTPUT 712; "at_a=0" OUTPUT 712; "at_b=70"
DA75	5	70	OUTPUT 712; "amp_in" OUTPUT 712; "at_a=50" OUTPUT 712; "at_b=70"
DA80	10	70	OUTPUT 712; "amp_in" OUTPUT 712; "at_a=10" OUTPUT 712; "at_b=70"
DA80a	0	80	OUTPUT 712; "amp_in" OUTPUT 712; "at_a=0" OUTPUT 712; "at_b=80"
DA85	5	80	OUTPUT 712; "amp_in" OUTPUT 712; "at_a=5" OUTPUT 712; "at_b=80"
DA90	10	80	OUTPUT 712; "amp_in" OUTPUT 712; "at_a=10" OUTPUT 712; "at_b=80"
DA90a	0	90	OUTPUT 712; "amp_in" OUTPUT 712; "at_a=0" OUTPUT 712; "at_b=90"
DA95	5	90	OUTPUT 712; "amp_in" OUTPUT 712; "at_a=5" OUTPUT 712; "at_b=90"
DA100	10	90	OUTPUT 712; "amp_in" OUTPUT 712; "at_a=10" OUTPUT 712; "at_b=90"
DA100a	0	100	OUTPUT 712; "amp_in" OUTPUT 712; "at_a=0" OUTPUT 712; "at_b=100"
DA105	5	100	OUTPUT 712; "amp_in" OUTPUT 712; "at_a=5" OUTPUT 712; "at_b=100"

Performance Tests
7. DYNAMIC ACCURACY TEST

Table 2-13 **Z5623A attenuator settings**

	A1 setting [dB]	A2 setting [dB]	GPIB command
DA110	10	100	OUTPUT 712; "amp_in" OUTPUT 712; "at_a=10" OUTPUT 712; "at_b=100"

Dynamic accuracy tests at -20 dBm to 0 dBm

Step 52. Set the first attenuator (A1) of the Z5623A to 10 dB and the second attenuator (A2) to 10 dB by executing the following GPIB control command:

GPIB:

```
OUTPUT 712; "amp_in"
OUTPUT 712; "at_a=10"
OUTPUT 712; "at_b=10"
```

Step 53. Adjust the source power for -10 dBm on the power meter display. Wait for power meter reading to settle when verifying the adjustment result.

NOTE

Since the source power resolution is 0.05 dB, adjust for the nearest possible value to 0 dBm.

Step 54. Perform Step 13 through 24.

Step 55. Set the first attenuator (A1) of the Z5623A to 5 dB by executing the following GPIB control command:

GPIB:

```
OUTPUT 712; "amp_in"
OUTPUT 712; "at_a=5"
OUTPUT 712; "at_b=10"
```

Step 56. Perform Step 13 through 24.

Step 57. Calculate the dynamic accuracy for -15 dBm using the following equation:

$$D.A. = (S_{xy} \times R @ DA15) - (S_{xy} \times R @ DA20) - (P_m @ DA15) + (P_m @ DA20)$$

Step 58. Record the calculated D.A. in the calculation sheet ("Running D.A. [dB]" and "True D.A. [dB]" columns for DA15).

Step 59. Set the first attenuator (A1) of the Z5623A to 0 dB by executing the following GPIB control command:

GPIB:

```
OUTPUT 712; "amp_in"
OUTPUT 712; "at_a=0"
OUTPUT 712; "at_b=10"
```

Step 60. Perform Step 13 through 24.

Step 61. Calculate the dynamic accuracy for -10 dBm using the following equation:

$$D.A. = (S_{xy} \times R @ DA10) - (S_{xy} \times R @ DA20) - (P_m @ DA10) + (P_m @ DA20)$$

- Step 62.** Record the calculated D.A. in the calculation sheet ("Running D.A. [dB]" and "True D.A. [dB]" columns for DA10).
- Step 63.** Set the first attenuator (A1) of the Z5623A to 10 dB and the second attenuator (A2) to 0 dB by executing the following GPIB control command:

GPIB:

```
OUTPUT 712; "amp_in"
OUTPUT 712; "at_a=10"
OUTPUT 712; "at_b=0"
```

This attenuator state is named DA10a.

- Step 64.** Perform Step 13 through 24.
- Step 65.** Calculate the difference in $S_{xy} \times R$ [dB] values for the DA10 and DA10a by using the following equation:

$$\Delta (S_{xy} \times R \text{ [dB]}) = (S_{xy} \times R \text{ [dB] @ DA10a}) - (S_{xy} \times R \text{ [dB] @ DA10})$$

- Step 66.** Adjust the source power for the following value on the power meter display.

$$\text{Target value} = (P_m \text{ [dB] @ DA10a}) - \Delta (S_{xy} \times R \text{ [dB]})$$

NOTE

It will be possible to promptly approximate the source power to the target value by decreasing the source power setting by $\Delta (S_{xy} \times R)$ from that for the DA10.

NOTE

After this adjustment is performed, the state is named DA10b.

- Step 67.** Perform Step 13 through 24.
- Step 68.** Set the first attenuator (A1) of the Z5623A to 5 dB by executing the following GPIB control command:

GPIB:

```
OUTPUT 712; "amp_in"
OUTPUT 712; "at_a=5"
OUTPUT 712; "at_b=0"
```

- Step 69.** Perform Step 13 through 24.
- Step 70.** Calculate the dynamic accuracy using the following equation:

$$D.A. = (S_{xy} \times R @ DA5) - (S_{xy} \times R @ DA10b) - (P_m @ DA5) + (P_m @ DA10b)$$

- Step 71.** Record the calculated D.A. in the calculation sheet ("Running D.A. [dB]" column for DA5).

- Step 72.** Calculate the true dynamic accuracy using the following equation:

$$\text{True D.A.} = (\text{Running D.A. [dB] @ DA5}) + (\text{True D.A. [dB] @ DA10})$$

- Step 73.** Record the true D.A. in the calculation sheet ("True D.A." column for DA5).

- Step 74.** Set the first attenuator (A1) of the Z5623A to 0 dB by executing the following GPIB

Performance Tests
7. DYNAMIC ACCURACY TEST

command:

GPIB:

```
OUTPUT 712; "amp_in"
OUTPUT 712; "at_a=0"
OUTPUT 712; "at_b=0"
```

Step 75. Perform Step 69 through 73 for DA0. (Obtain the values for DA0 in place of DA5.)

Step 76. Record the true D.A values in the performance test record ("Dynamic accuracy" column for the dynamic accuracy test).

Dynamic accuracy tests for other test ports

Step 77. Connect the test equipment and select S-parameter in accordance with Table 2-14.

Step 78. Perform Step 11 through 76 for each test setup and S-parameter shown in Table 2-14.

Table 2-14 Dynamic accuracy test setups and S-parameter settings

S-Parameter setting	Test setup		
	Opt. 213/214	Opt. 313/314	Opt. 413/414
S12	Figure 2-35	Figure 2-36	Figure 2-38
S31	Not required	Figure 2-37	Figure 2-39
S41	Not required	Not required	Figure 2-40

Figure 2-35 Dynamic accuracy test setup (Opt. 213/214)

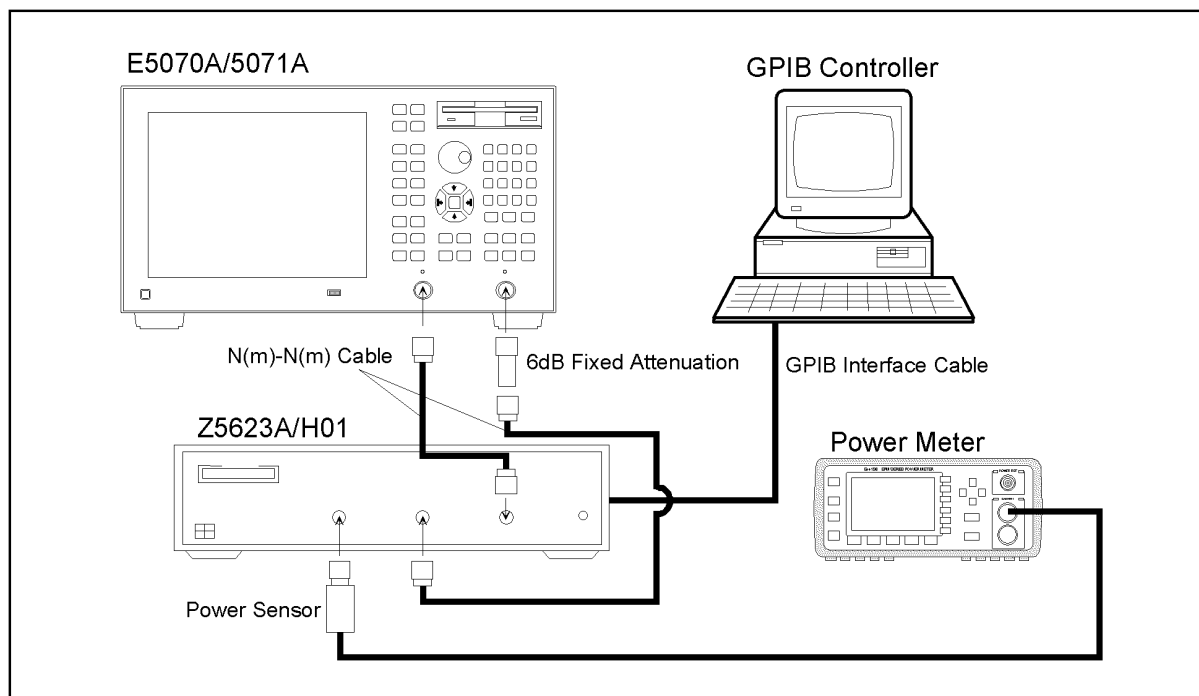

e5070ase024

Figure 2-36 Dynamic accuracy test setup (Opt. 313/314)

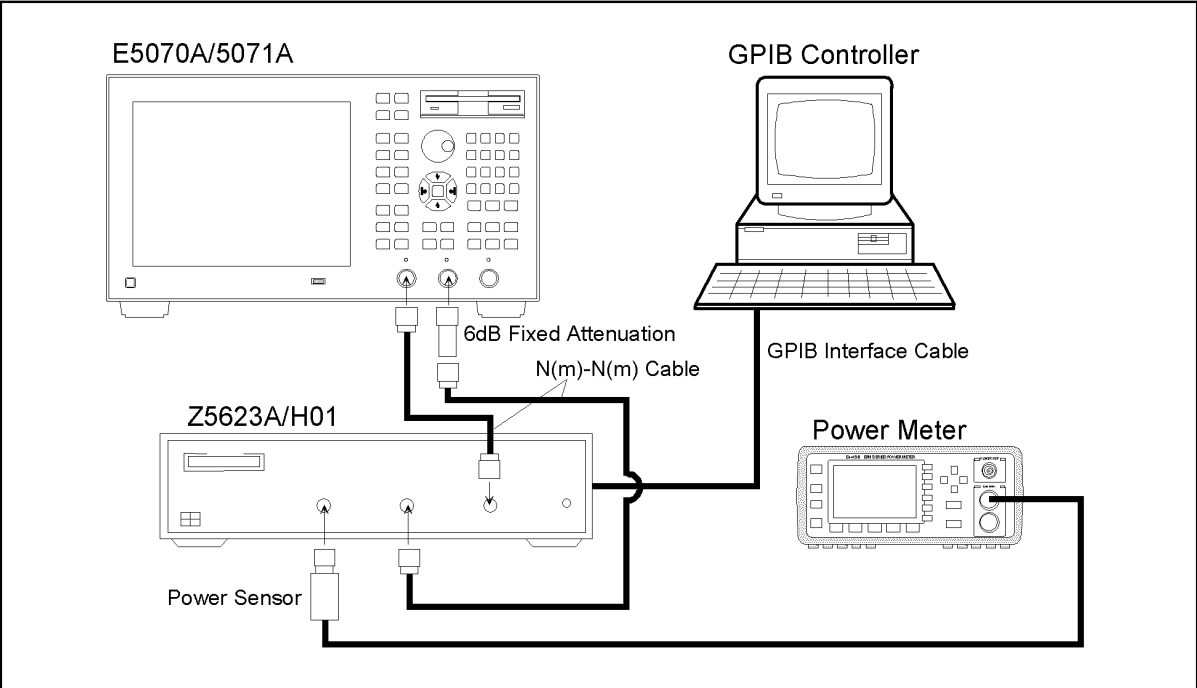
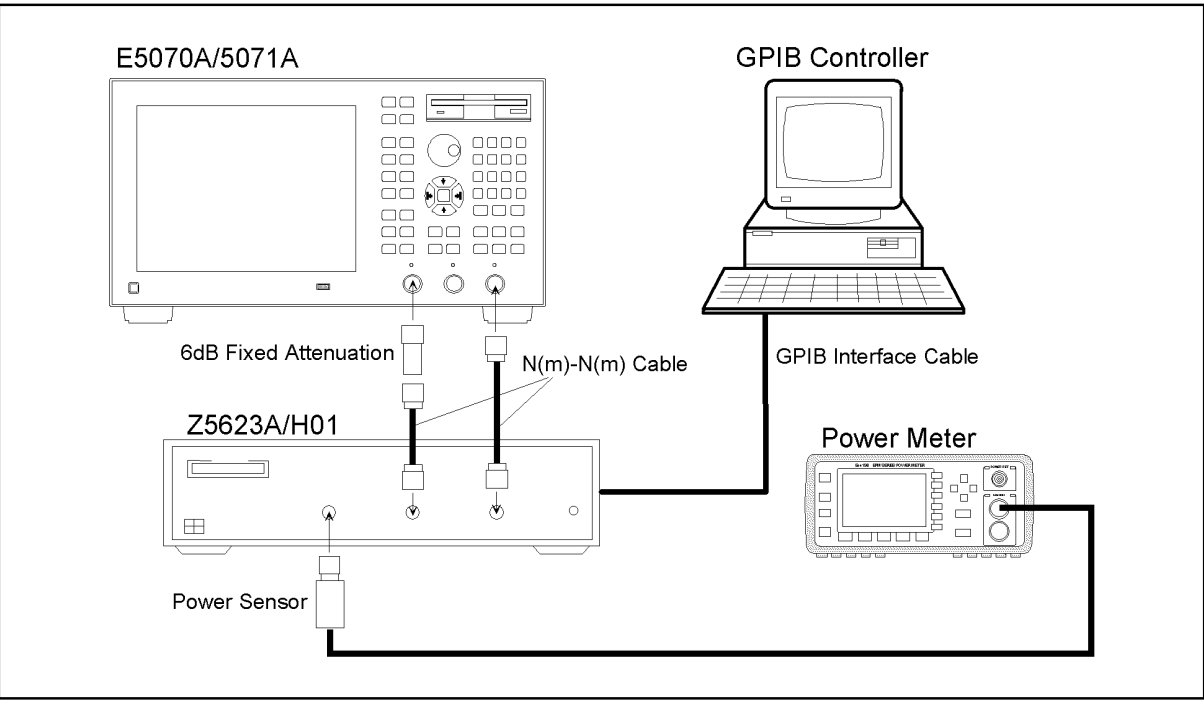
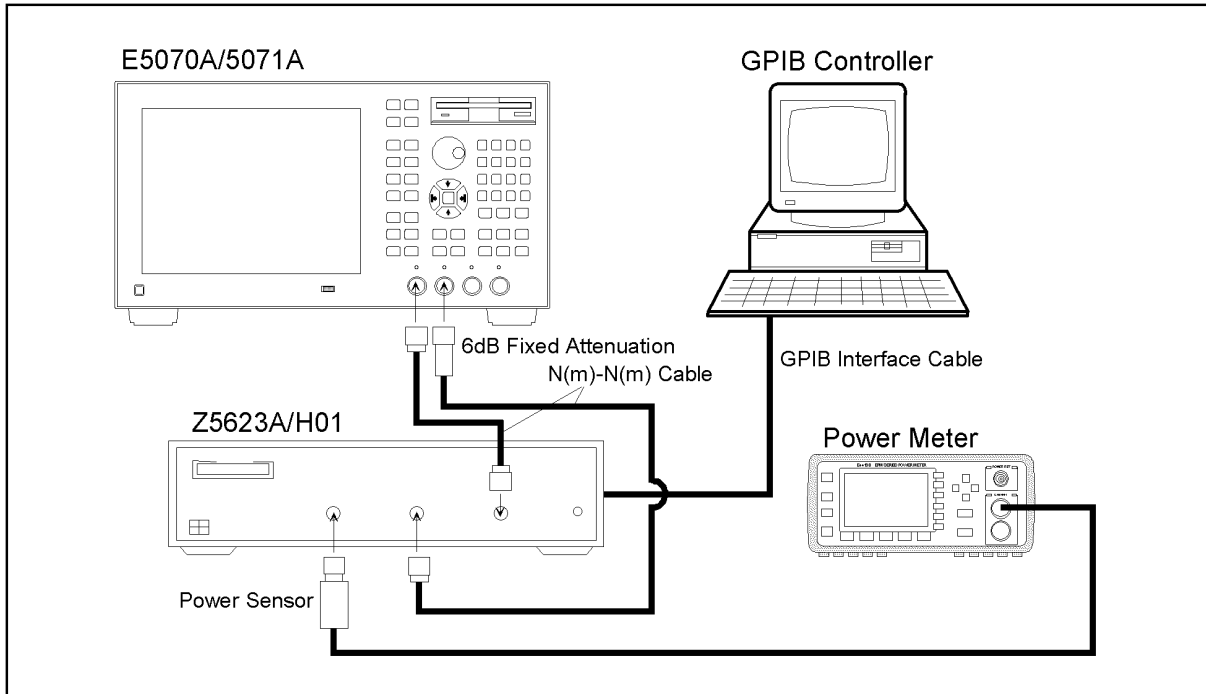

Figure 2-37 Dynamic accuracy test setup (Opt. 313/314)



Performance Tests
7. DYNAMIC ACCURACY TEST

Figure 2-38 Dynamic accuracy test setup (Opt. 413/414)



e5070ase031

Figure 2-39 Dynamic accuracy test setup (Opt. 413/414)

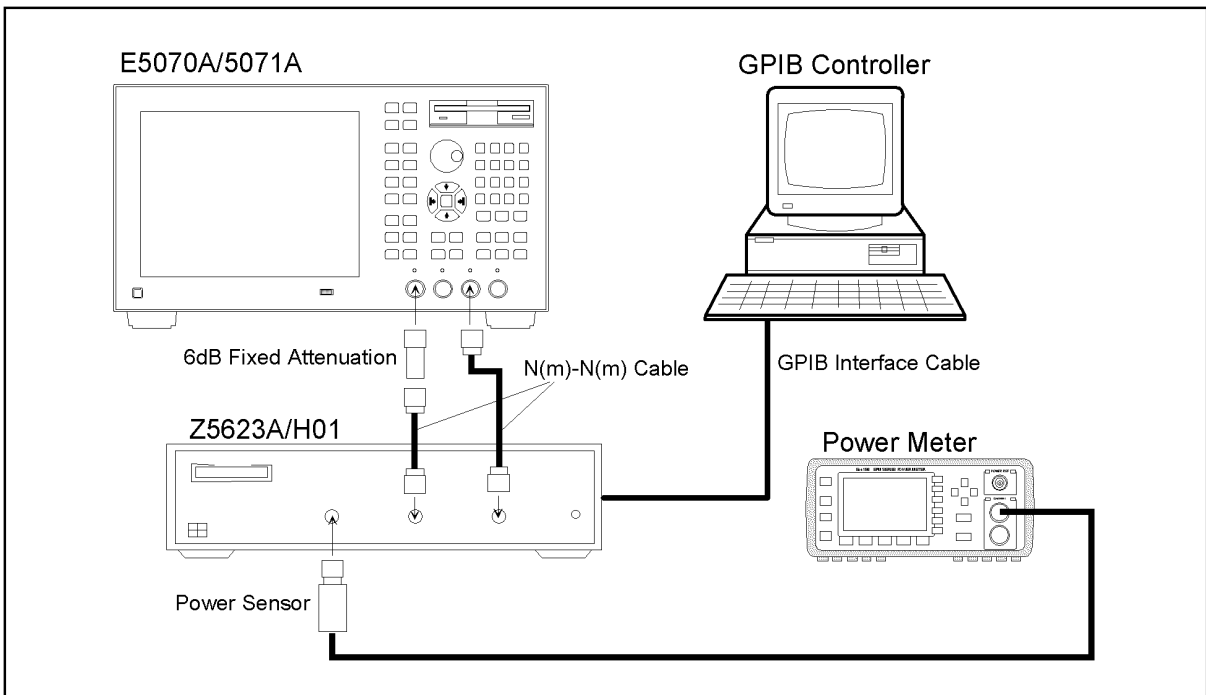

e5070ase029

Figure 2-40 Dynamic accuracy test setup (Opt. 413/414)

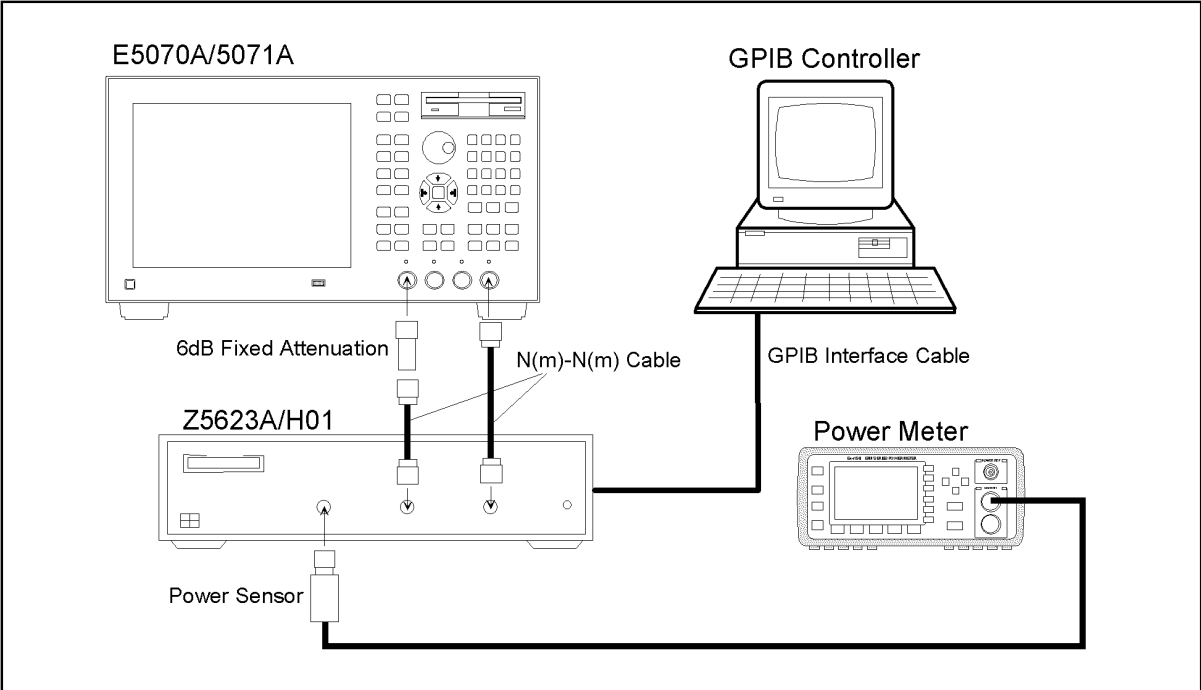

e5070ase030

2. Performance Test

8. UNCORRECTED SYSTEM PERFORMANCE TEST

Description

This test checks the directivity, source match and load match, which are the key S-parameter measurement hardware characteristics. These characteristics are tested using the Agilent 85032F Calibration Kit at 3MHz, 10 MHz, as well as 50 MHz increments from 50 MHz to 3 GHz (up to 8.5 GHz for the E5071A). After a full two-port (SOLT) calibration is performed for each test port, VBA test programs are executed to output the directivity, source match and load match data to the display.

NOTE

The VBA test programs for the Uncorrected System Performance Test are not available in the current version of the E5070A/E5071A test procedure. The test procedure is made effective when the test programs become available.

Specification

Table 2-15 Directivity, source match and load match specification

	Frequency	Directivity	Source match	Load match
E5070A/E5071A	3 MHz to 3 GHz	10 dB	15 dB	17 dB
E5071A only	3 GHz to 6 GHz	6 dB	10 dB	12 dB
	6 GHz to 8.5 GHz	4 dB	10 dB	12 dB

Test Equipment

Calibration Kit	Agilent 85032F
Coaxial cable with N-type (m) connectors, 61 cm (24 in)	Agilent N6314A (p/n 8120-8862)

Procedure

Step 1. Connect the N-N cable as shown in the following figure:

Option 213/214: Figure 2-41.

Option 313/314: Figure 2-42.

Option 413/414: Figure 2-43.

For the connection of the Open, Short and Load terminations, obey the instruction in the following procedure.

Figure 2-41 O/S/L calibration setup for uncorrected system performance test (Opt. 213/214)

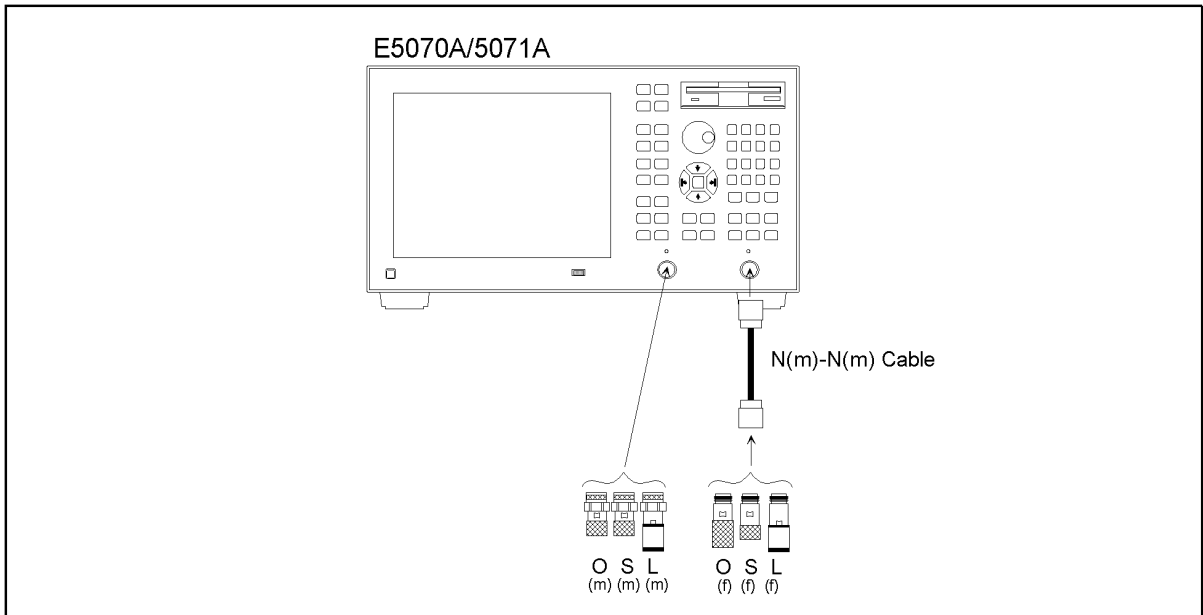

e5070ase036

Figure 2-42 O/S/L calibration setup for uncorrected system performance test (Opt. 313/314)

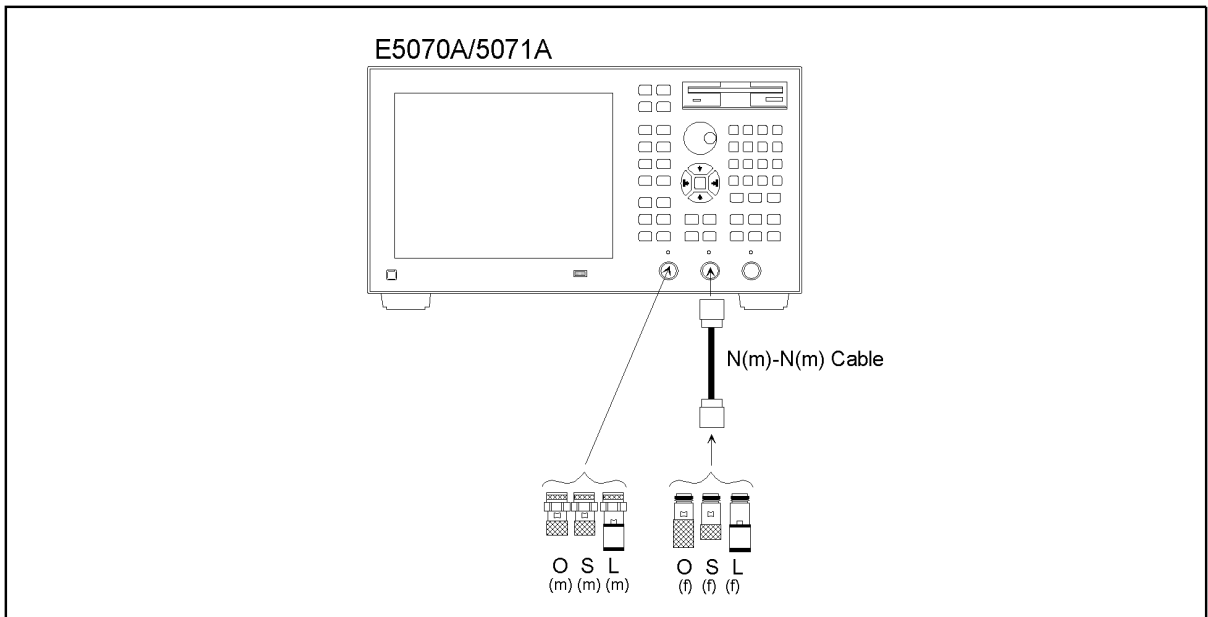

e5070ase038

2. Performance Test

8. UNCORRECTED SYSTEM PERFORMANCE TEST

Figure 2-43 O/S/L calibration setup for uncorrected system performance test (Opt. 413/414)

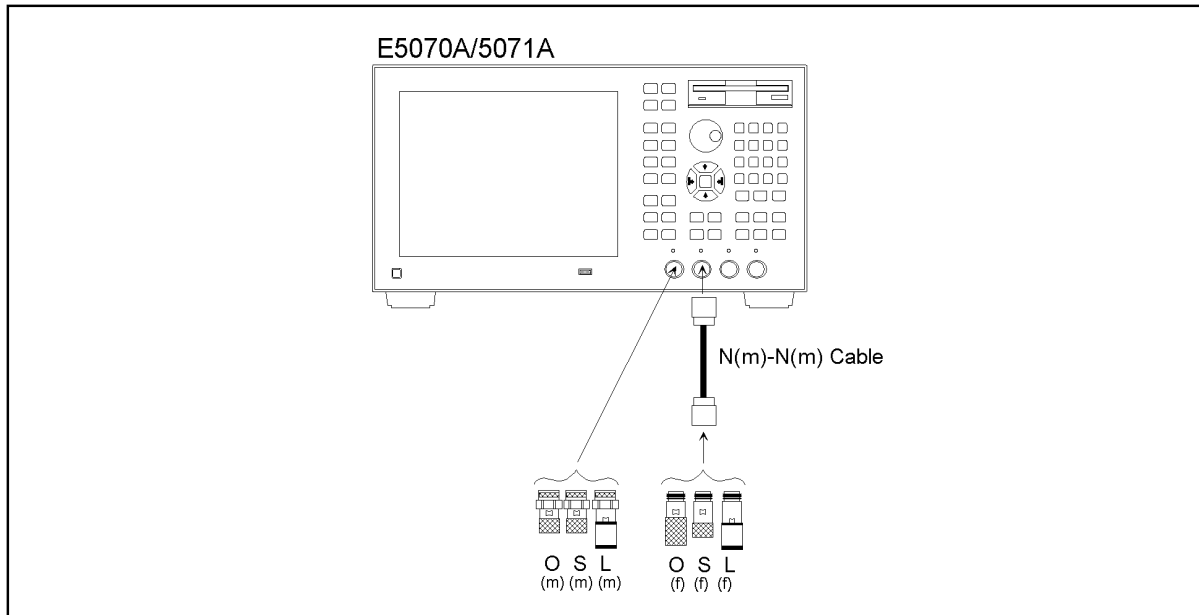

e5070ase040

NOTE

To avoid possible variance in measured values, do not touch or move the N-N cable during measurements.

Step 2. Press **Preset** and **Enter** to initialize the E5070A/E5071A.

Step 3. Set **System Correction** function to **OFF** in accordance with the following procedure:

- Press **System** - **↓** - **↓** - **↓** - **↓** - **↓** - **↓** - **↓** - **↓** - **↓** - **↓** - **↓** - **↓** - **↓** - **↓** - **↓** (select **Service Menu**), **Enter**.
- Confirm that the System Correction is **OFF**. If it is **ON**, proceed to the next c and d.
- Press **↓** (select **System Correction "ON"**), **Enter**.
- The message box is displayed. Then press **OK** button. The **System Correction** function will be changed to **OFF**.

Step 4. Press **Format** and select **Log Mag** from display format menu.

Step 5. Set the test frequencies using the Segment Table as follows:

- Press **Sweep Setup** - **↓** - **↓** - **↓** - **↓** - **↓** - **↓** - **↓** - **↓** (select **Edit Segment Table**) - **Enter**.
The first "Start" frequency entry box in the Segment Sweep table will be focused.
- Press **3** - **M/μ** to enter 3 MHz as the start frequency. "Stop" frequency will be focused.
- Press **1** - **0** - **M/μ** to enter 10 MHz as the stop frequency. "Points" will be automatically set to 2.
- Press **↓** - **←** - **←** to focus on the "Start" frequency of the second segment.

8. UNCORRECTED SYSTEM PERFORMANCE TEST

- e. Press **5** - **0** - **M/μ** to enter 50 MHz. The "Stop" frequency will be focused.
- f. For the E5070A, proceed to the next Step g. For the E5071A, skip to Step i.

E5070A

- g. Press **3** - **G/n** to enter 3 GHz as the stop frequency. "Points" will be focused.
- h. Press **6** - **0** - **x1** to set the number of sweep points to 60. Then, proceed to step 5.

NOTE

The sweep frequency points for the second segment will be aligned in 50 MHz increments from 50 MHz to 3 GHz.

NOTE

See Table 2-16 for the entire Segment Table setting for the E5070A

Table 2-16

E5070A Segment Table setting

	Start	Stop	Points
1	3 MHz	10 MHz	2
3	50 MHz	3 GHz	60

E5071A

- i. Press **8** - **.** - **5** - **G/n** to enter 8.5 GHz as the stop frequency. "Points" will be focused.
- j. Press **1** - **7** - **0** - **x1** to set the number of sweep points to 170.

NOTE

The sweep frequency points for the second segment will be aligned in 50 MHz increments from 50 MHz to 8.5 GHz.

NOTE

See Table 2-17 for the entire Segment Table setting for the E5071A

Table 2-17

E5071A Segment Table setting

	Start	Stop	Points
1	3 MHz	10 MHz	2
3	50 MHz	8.5 GHz	170

- Step 6.** Press **Sweep Setup** - **↓** - **↓** - **↓** - **↓** - **↓** - **↓** (select **Sweep Type**) - **Enter** to set the **Sweep type** to **Segment**.

Full 2-port calibration

- Step 7.** Press **Cal** - **↓** - **↓** - **↓** - **↓** and **Enter** to select **Cal Kit**.
- Step 8.** Press **↓** - **↓** - **↓** and **Enter** to select **85032F**.

NOTE

If **Cal Kit** is set to **85032F***, press **↓** , **Enter** , **↓** - **↓** - **↓** - **Enter** - **Enter** to

8. UNCORRECTED SYSTEM PERFORMANCE TEST

select **Restore Cal Kit**.

- Step 9.** Press **Cal** - **↓** and **Enter** to select **Calibrate** function.
- Step 10.** Press **↓** - **↓** - **↓** - **↓** and **Enter** to select **2-Port Cal**.
- Step 11.** Press **Enter** to go down to **Select Ports** menu.
- Step 12.** Select **1-2** (preset ports).
- Step 13.** Press **↓** and **Enter** to select **Reflection** calibration and to go down to its menu.
- Step 14.** Connect Open termination to the Port 1 and perform **Port 1 Open** calibration.
- Step 15.** Perform **Port 1 Short** calibration with Short termination connected to the Port 1.
- Step 16.** Perform **Port 1 Load** calibration with Load termination Connected to the Port 1.
- Step 17.** Connect Open termination to the tip of the N-N cable connected to the Port 2 and perform **Port 2 open** calibration.
- Step 18.** Perform **Port 2 Short** calibration with Short termination connected to the tip of the N-N cable.
- Step 19.** Perform **Port 2 Load** calibration with Load termination connected to the tip of the N-N cable.
- Step 20.** Perform **Return**.
- Step 21.** Connect the N-N cable between the selected test ports (Port 1 and Port 2) as shown in the following figures:

Option 213/214: Figure 2-44.

Option 313/314: Figure 2-45.

Option 413/414: Figure 2-46.

Figure 2-44 Thru calibration setup for uncorrected system performance test (Opt. 213/214)

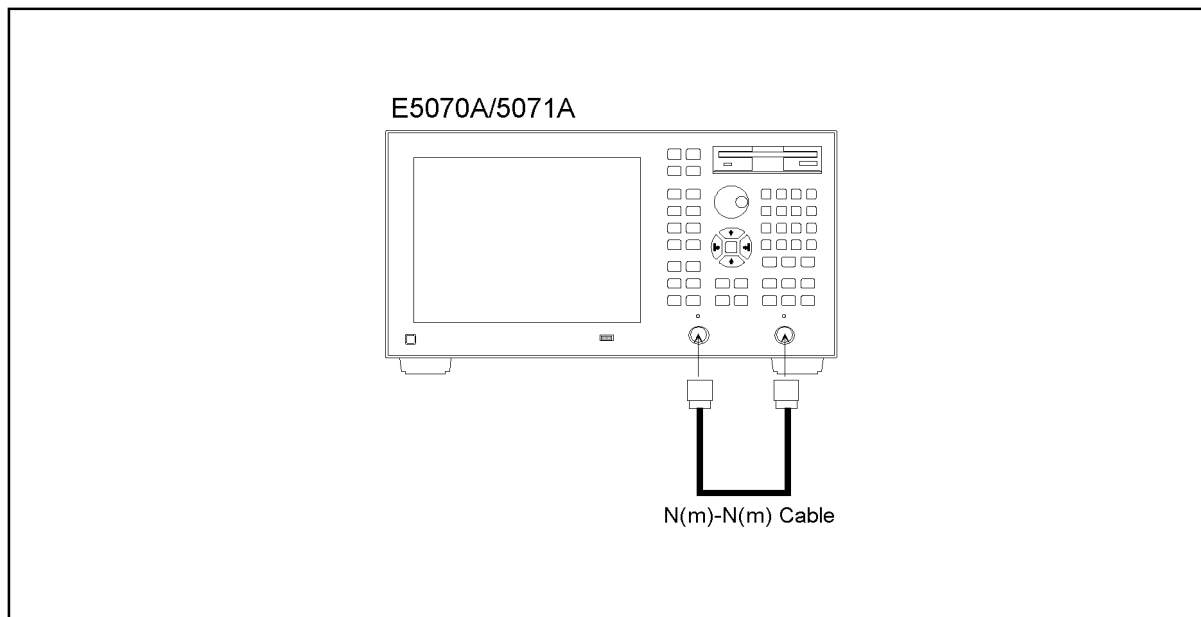

e5070ase010

Figure 2-45 Thru calibration setup for uncorrected system performance test (Opt. 313/314)

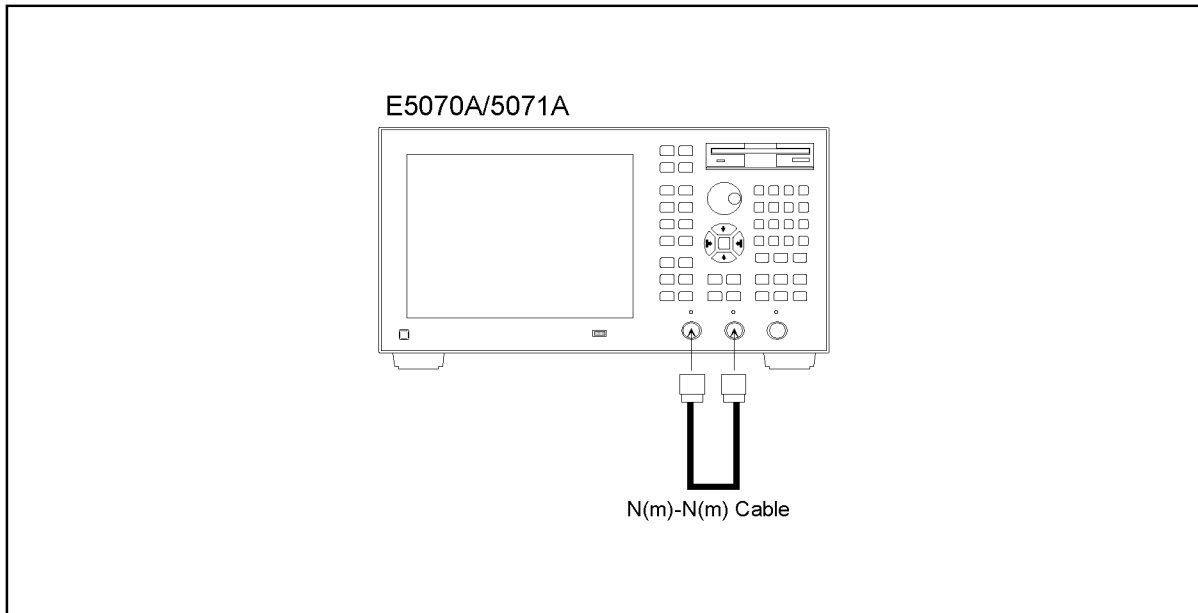

e5070ase011

Figure 2-46 Thru calibration setup for uncorrected system performance test (Opt. 413/414)

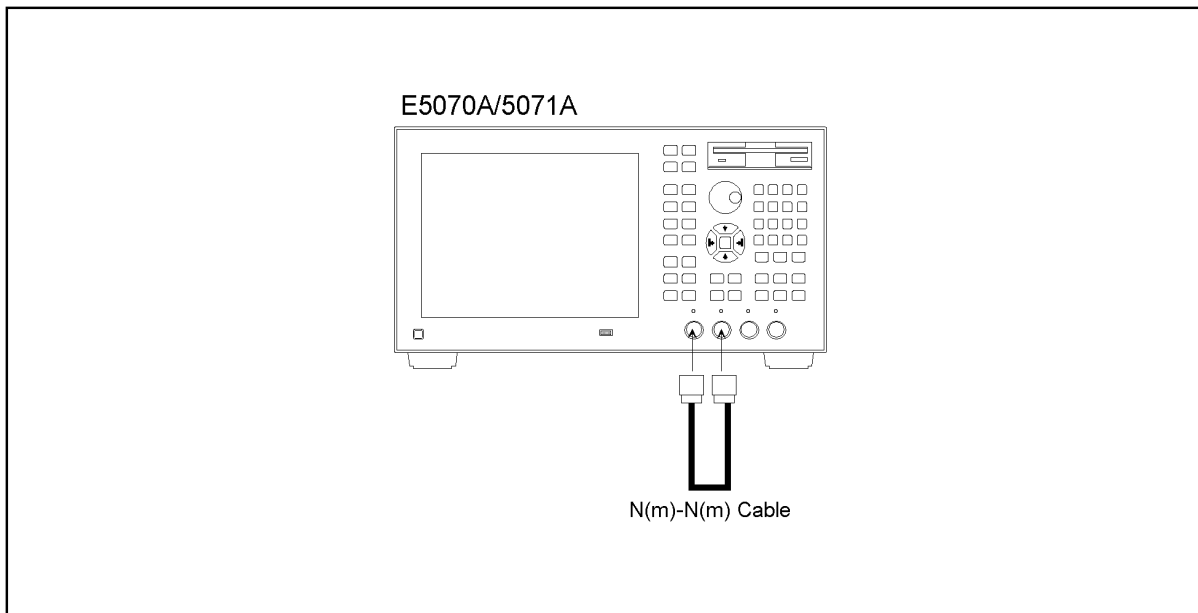

e5070ase013

Step 22. Press and to select **Transmission** calibration and to go down to its menu.

Step 23. Press to perform **Port 1-2 Thru** calibration.

Step 24. Perform **Return**.

Step 25. Press - - to Perform **Done**.

Step 26. Press and verify that the **Correction** function is set to ON.

8. UNCORRECTED SYSTEM PERFORMANCE TEST

Directivity, source match and load match test

Step 27. Press **Macro Setup** - **Load Project**. Open “uncorrected_system_test.vba”.

NOTE

The program “uncorrected_system_test.vba” can be downloaded from Agilent Technologies web site to a floppy disk using you computer’s FDD.

Step 28. Press **Macro Run** to run the test program. This test program displays the values of the directivity, source match and load match at each sweep frequency point, and extracts the maximum value for each of the following frequency ranges:

E5070A: 3 MHz to 3 GHz (1 range)

E5071A: 3 MHz to 3 GHz, 3 GHz to 6 GHz, 6 GHz to 8.5 GHz (3 ranges)

The maximum value in each frequency range is represented in dB and displayed in the VBA UserForm window as shown in the display example below.

Directivity test for port 1

a. Set **Parameter, Response Port and Stimulus Port** as shown in Figure 2-47.

Figure 2-47 Directivity test window

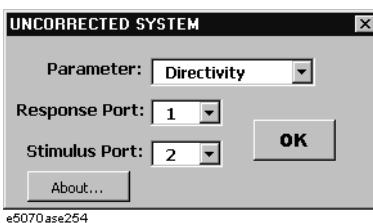

b. Press **OK** button. The maximum value in each frequency range is displayed as shown in Figure 2-48 or Figure 2-49.

Figure 2-48 Directivity for E5070A

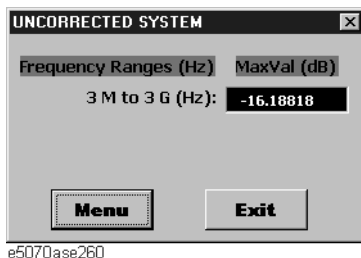

8. UNCORRECTED SYSTEM PERFORMANCE TEST

Figure 2-49 Directivity for E5071A

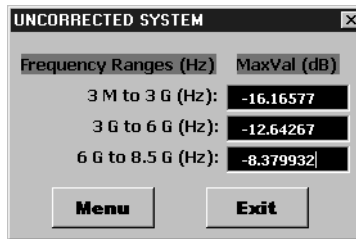

e5070ase255

- c. Record the displayed values in the performance test record (“Test results [dB]” column in “Port 1” table for the uncorrected system performance test).

Source match test for port 1

- d. Set **Parameter**, **Response Port** and **Stimulus Port** as shown in Figure 2-50.

Figure 2-50 Source match test window

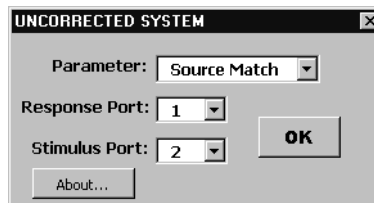

e5070ase256

- e. Press **OK** button. The maximum value in each frequency range is displayed as shown in Figure 2-51 or Figure 2-52.

Figure 2-51 Source match for E5070A

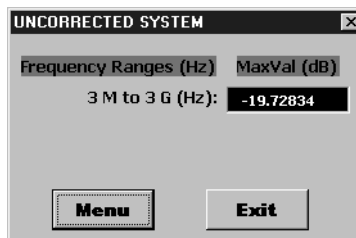

e5070ase261

Figure 2-52 Source match for E5071A

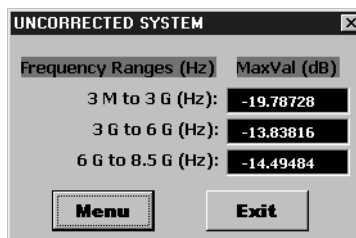

e5070ase257

- f. Record the displayed values in the performance test record (“Test results [dB]” column in “Port 1” table for the uncorrected system performance test).

8. UNCORRECTED SYSTEM PERFORMANCE TEST

Load match test for port 1

- g. Set **Parameter**, **Response Port** and **Stimulus Port** as shown in Figure 2-53.

Figure 2-53 Load match test window

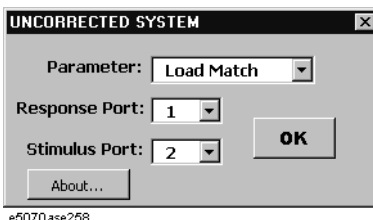

- h. Press **OK** button. The maximum value in each frequency range is displayed as shown in Figure 2-54 or Figure 2-55.

Figure 2-54 Load match for E5070A

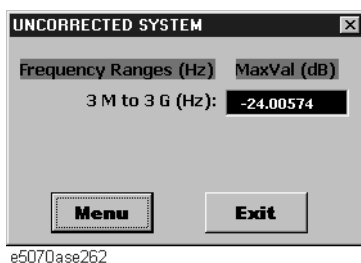
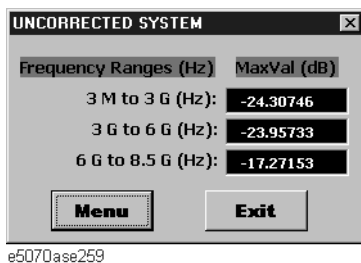

Figure 2-55 Load match for E5071A



- i. Record the displayed values in the performance test record ("Test results [dB]" column in "Port 1" table for the uncorrected system performance test).

Test procedure for other test setups

Step 29. Connect the N-N cable as shown in the following figures:

- Option 213/214: Figure 2-56.
- Option 313/314: Figure 2-57.
- Option 413/414: Figure 2-58.

NOTE

The test setups and **Select Ports** settings for each option configuration are described in Table 2-18.

Figure 2-56 O/S/L calibration setup for uncorrected system performance test (Opt. 213/214)

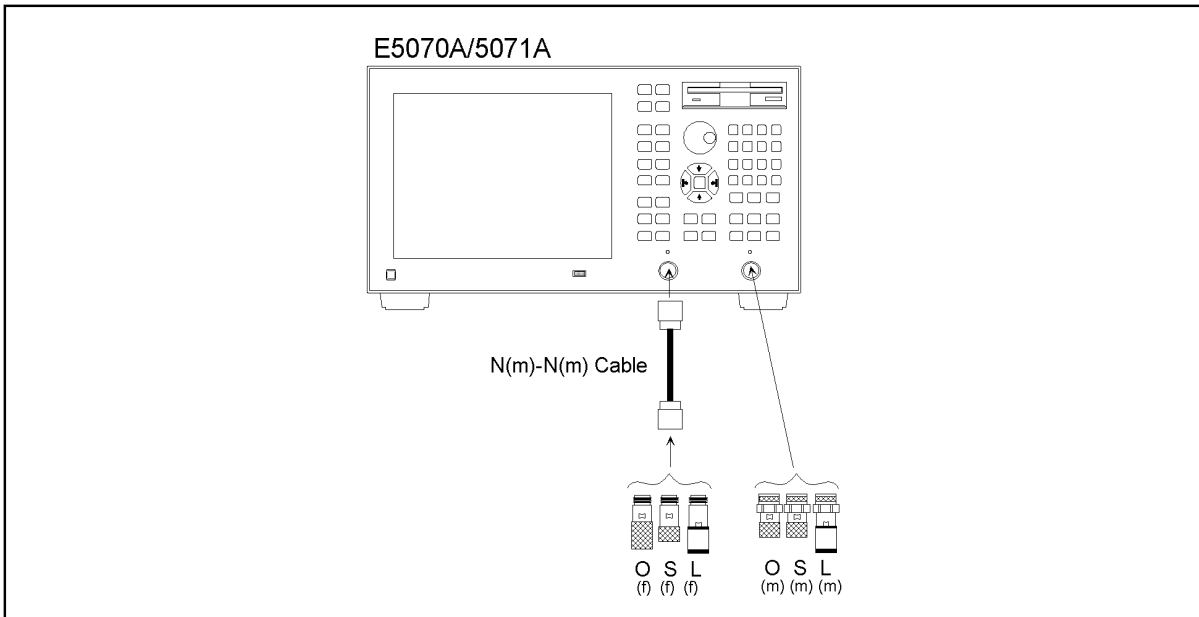

e5070ase035

Figure 2-57 O/S/L calibration setup for uncorrected system performance test (Opt. 313/314)

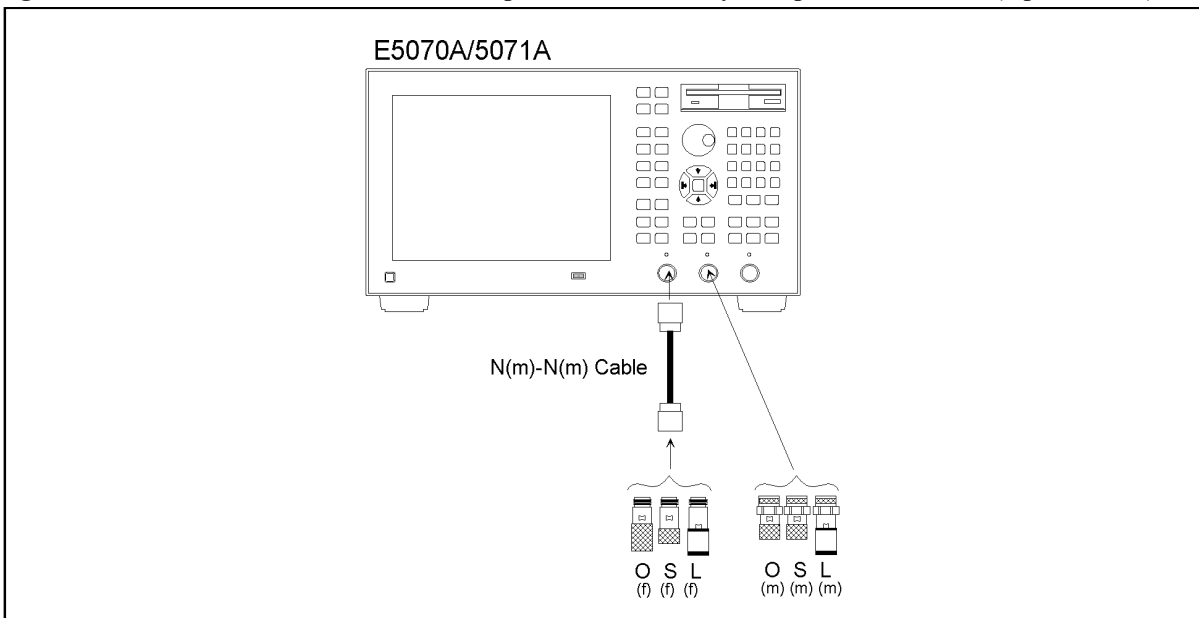

e5070ase037

8. UNCORRECTED SYSTEM PERFORMANCE TEST

Figure 2-58 O/S/L calibration setup for uncorrected system performance test (Opt. 413/414)

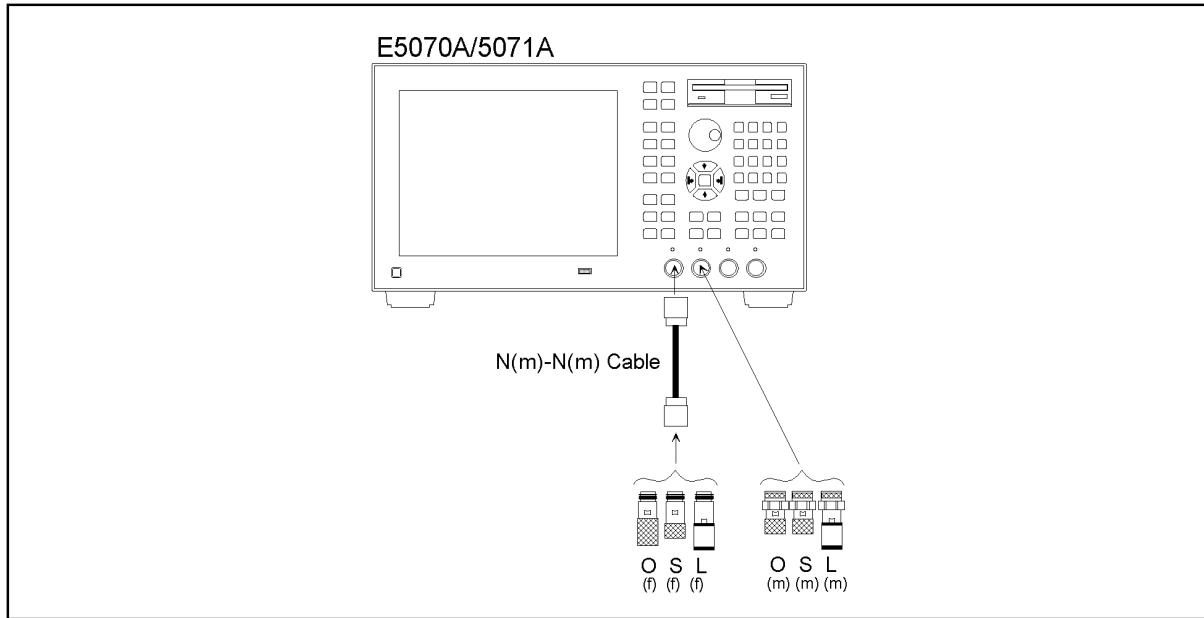

e5070ase041

Step 30. Perform the full 2-port calibration (Step 9 through 26) in accordance with Table 2-18.

Step 31. Perform Step 28 and 29. Record the directivity, source match and load match values in the performance test record ("Port 2" table).

Options 313, 314, 413 and 414 only

NOTE

Perform Step 32 and 33 for the option 313, 314, 413 and 414 instruments only.

Step 32. Perform the full 2-port calibration (Step 6 through 26) in accordance with Table 2-18.

Step 33. Perform Step 28 and 29. Record the directivity, source match and load match values in the performance test record ("Port 1" through "Port 3" tables for Option 313/314 and "Port 1" through "Port 4" tables for Option 413/414).

8. UNCORRECTED SYSTEM PERFORMANCE TEST

Table 2-18 Test setup, Select Ports settings and calibration sequence

Option	Select Ports	Test setup (Figure)	Calibration	Termination and cable connection for calibration
213/214	1-2	Figure 2-41	Port 1 Open	"Open" to Port 1
			Port 1 Short	"Short" to Port 1
			Port 1 Load	"Load" to Port 1
			Port 2 Open	"Open" to the tip of N-N cable
			Port 2 Short	"Short" to the tip of N-N cable
			Port 2 Load	"Load" to the tip of N-N cable
		Figure 2-44	Thru	N-N cable between Port 1 and Port 2
	Perform Step 28 and 29. Response/Stimulus Port of Directivity/Source match/Load match test are as follows; Response Port: 1, Stimulus Port : 2 Record the test results in the performance test record ("port 1").			
	1-2	Figure 2-56	Port 1 Open	"Open" to the tip of N-N cable
			Port 1 Short	"Short" to the tip of N-N cable
			Port 1 Load	"Load" to the tip of N-N cable
			Port 2 Open	"Open" to Port 2
			Port 2 Short	"Short" to Port 2
			Port 2 Load	"Load" to Port 2
Figure 2-44		Thru	N-N cable between Port 1 and Port 2	
Perform Step 28 and 29. Response/Stimulus Port of Directivity/Source match/Load match test are as follows; Response Port: 2, Stimulus Port : 1 Record the test results in the performance test record ("port 2").				

8. UNCORRECTED SYSTEM PERFORMANCE TEST

Table 2-18 Test setup, Select Ports settings and calibration sequence

Option	Select Ports	Test setup (Figure)	Calibration	Termination and cable connection for calibration
313/314	1-2	Figure 2-42	Port 1 Open/Short/Load and Port 2 Open/Short/Load	Same as Opt. 213/214 (N-N cable connected to Port 2) Refer to Step 9 through 26 for the details.
		Figure 2-45	Thru	N-N cable between Port 1 and Port 2
		Perform Step 28 and 29. Response/Stimulus Port of Directivity/Source match/Load match test are as follows; Response Port: 1, Stimulus Port : 2 Record the test results in the performance test record ("port 1").		
	1-2	Figure 2-57	Port 1 Open/Short/Load and Port 2 Open/Short/Load	Same as Opt. 213/214 (N-N cable connected to Port 1)
		Figure 2-45	Thru	N-N cable between Port 1 and Port 2
		Perform Step 28 and 29. Response/Stimulus Port of Directivity/Source match/Load match test are as follows; Response Port: 2, Stimulus Port : 1 Record the test results in the performance test record ("port 2").		
	1-3	Figure 2-59	Port 1 Open	"Open" to the tip of N-N cable
			Port 1 Short	"Short" to the tip of N-N cable
			Port 1 Load	"Load" to the tip of N-N cable
			Port 3 Open	"Open" to Port 3
			Port 3 Short	"Short" to Port 3
			Port 3 Load	"Load" to Port 3
		Figure 2-60	Thru	N-N cable between Port 1 and Port 3
	Perform Step 28 and 29. Response/Stimulus Port of Directivity/Source match/Load match test are as follows; Response Port: 3, Stimulus Port : 1 Record the test results in the performance test record ("port 3").			

8. UNCORRECTED SYSTEM PERFORMANCE TEST

Table 2-18 Test setup, Select Ports settings and calibration sequence

Option	Select Ports	Test setup (Figure)	Calibration	Termination and cable connection for calibration
413/414	1-2	Figure 2-43	Port 1 Open/Short/Load and Port 2 Open/Short/Load	Same as Opt. 213/214 (N-N cable connected to Port 2) Refer to Step 9 through 26 for the details.
		Figure 2-46	Thru	N-N cable between Port 1 and Port 2
	Perform Step 28 and 29. Response/Stimulus Port of Directivity/Source match/Load match test are as follows; Response Port: 1, Stimulus Port : 2 Record the test results in the performance test record ("port 1").			
	1-2	Figure 2-58	Port 1 Open/Short/Load and Port 2 Open/Short/Load	Same as Opt. 213/214 (N-N cable connected to Port 1)
		Figure 2-46	Thru	N-N cable between Port 1 and Port 2
	Perform Step 28 and 29. Response/Stimulus Port of Directivity/Source match/Load match test are as follows; Response Port: 2, Stimulus Port : 1 Record the test results in the performance test record ("port 2").			
	3-4	Figure 2-61	Port 3 Open	"Open" to Port 3
			Port 3 Short	"Short" to Port 3
			Port 3 Load	"Load" to Port 3
			Port 4 Open	"Open" to the tip of N-N cable
Port 4 Short			"Short" to the tip of N-N cable	
Port 4 Load			"Load" to the tip of N-N cable	
Figure 2-62		Thru	N-N cable between Port 3 and Port 4	
Perform Step 28 and 29. Response/Stimulus Port of Directivity/Source match/Load match test are as follows; Response Port: 3, Stimulus Port : 4 Record the test results in the performance test record ("port 3").				

8. UNCORRECTED SYSTEM PERFORMANCE TEST

Table 2-18 Test setup, Select Ports settings and calibration sequence

Option	Select Ports	Test setup (Figure)	Calibration	Termination and cable connection for calibration
	3-4	Figure 2-63	Port 3 Open	"Open" to the tip of N-N cable
			Port 3 Short	"Short" to the tip of N-N cable
			Port 3 Load	"Load" to the tip of N-N cable
			Port 4 Open	"Open" to Port 4
			Port 4 Short	"Short" to Port 4
			Port 4 Load	"Load" to Port 4
	Figure 2-62	Thru	N-N cable between Port 3 and Port 4	
Perform Step 28 and 29. Record the test results in the performance test record ("port 4") Response/Stimulus Port of Directivity/Source match/Load match test are as follows; Response Port: 4, Stimulus Port : 3 Record the test results in the performance test record ("port 4").				

Figure 2-59 O/S/L calibration setup for uncorrected system performance test (Opt. 313/314)

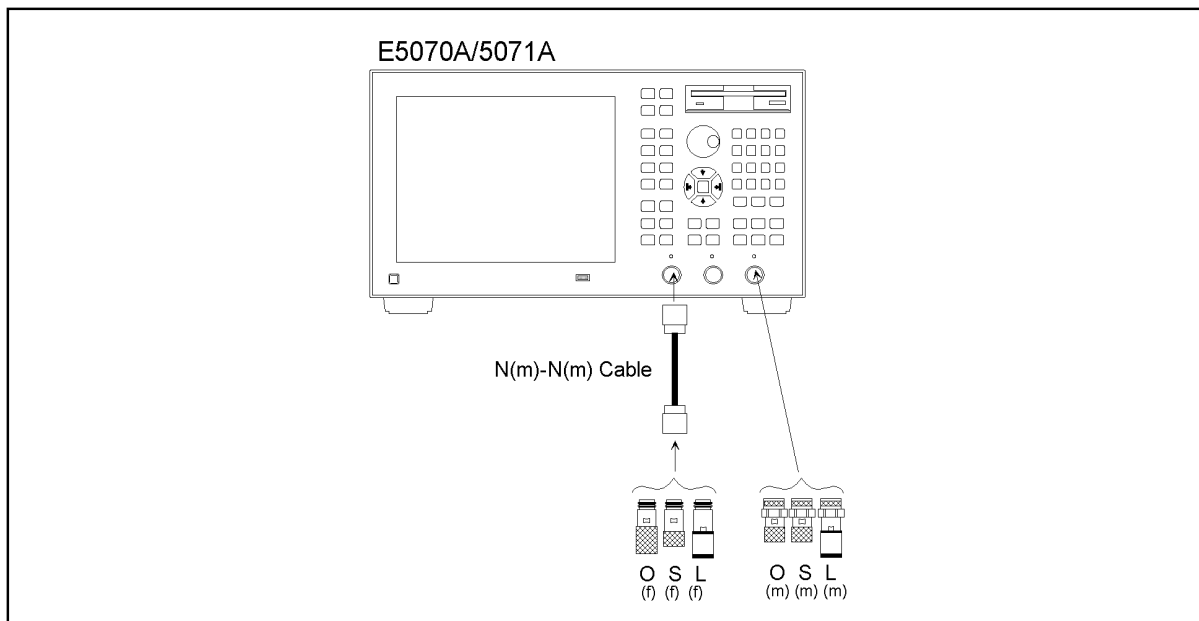

e5070ase039

Figure 2-60 Thru calibration setup for uncorrected system performance test (Opt. 313/314)

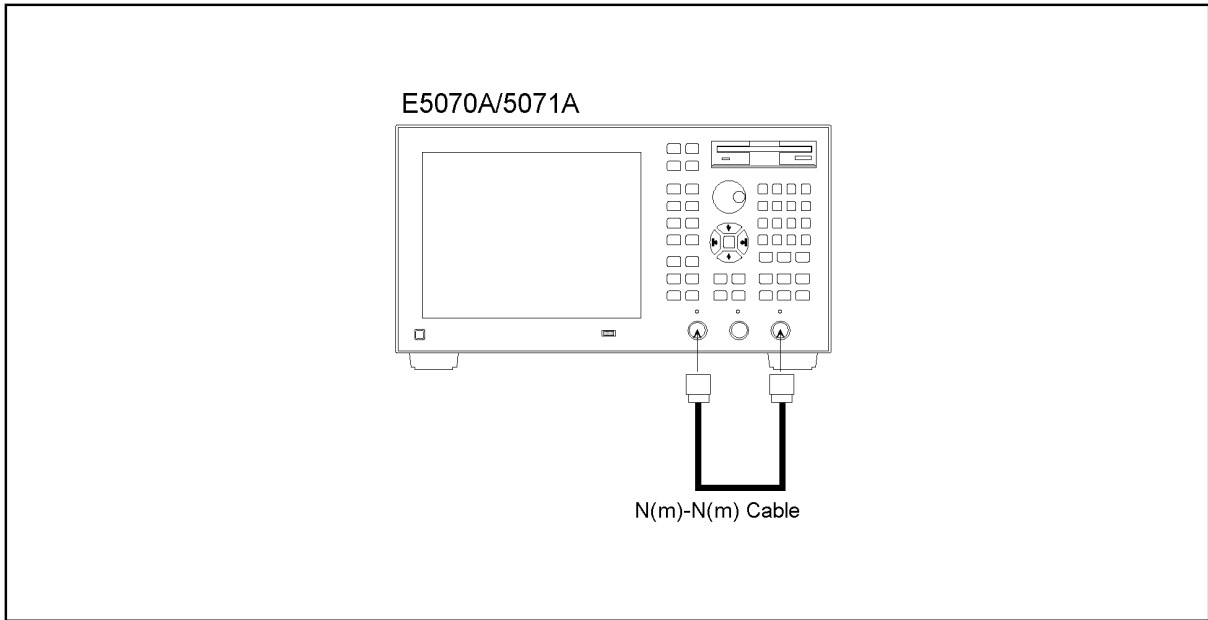

e5070ase044

2. Performance Test

Figure 2-61 O/S/L calibration setup for uncorrected system performance test (Opt. 413/414)

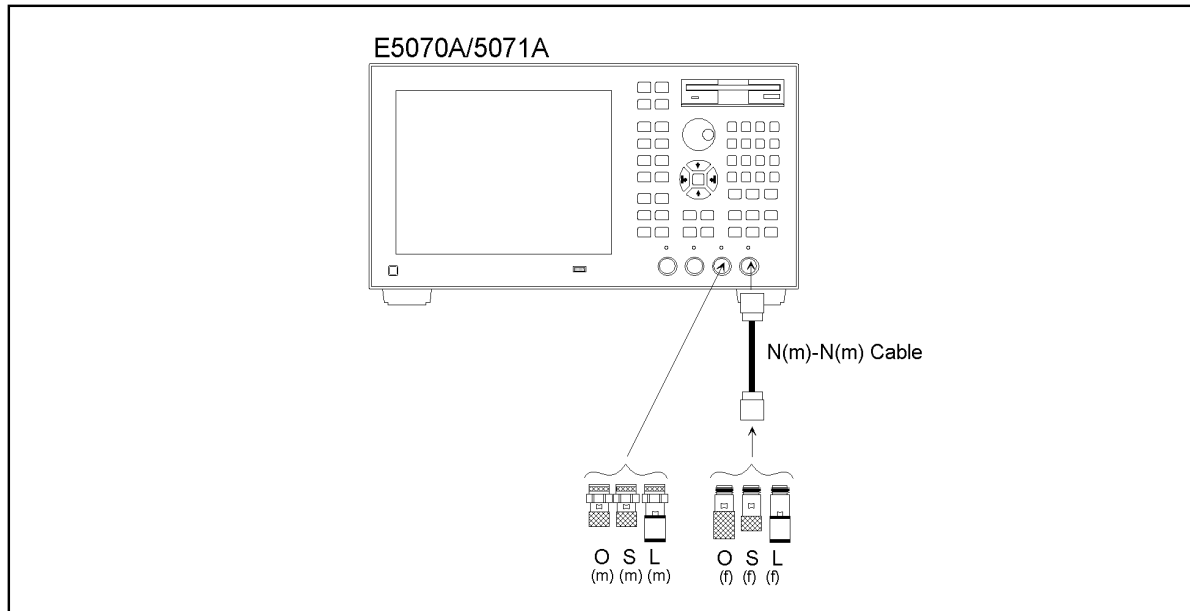

e5070ase042

8. UNCORRECTED SYSTEM PERFORMANCE TEST

Figure 2-62 Thru calibration setup for uncorrected system performance test (Opt. 413/414)

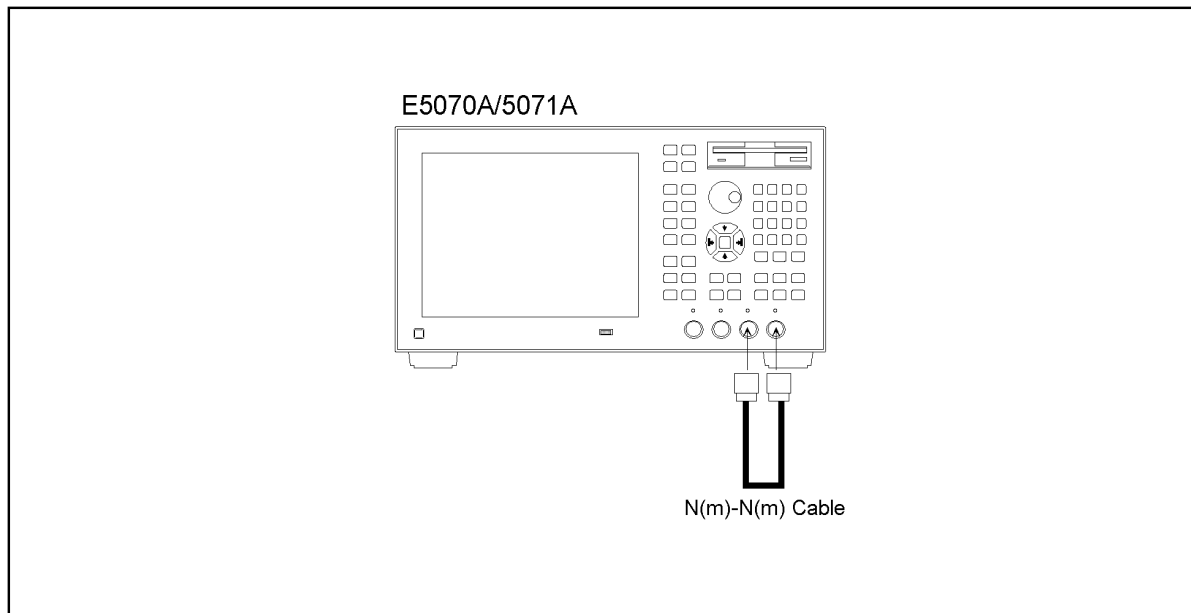

e5070ase014

Figure 2-63 O/S/L calibration setup for uncorrected system performance test (Opt. 413/414)

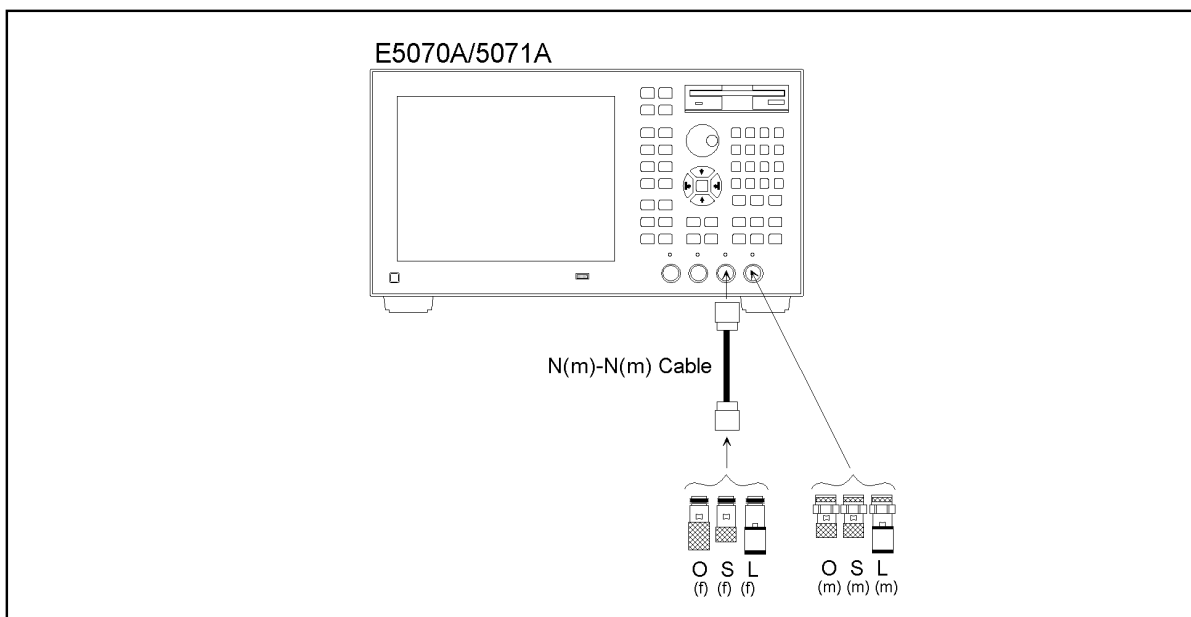

e5070ase043

E5070A/E5071A Performance Test Calculation Sheet

Introduction

This section contains calculation sheets for each performance test that requires additional calculations to determine the final test result.

Use the calculation sheet in this section as an aid for recording raw measurement data and calculating the performance test results.

Calculation sheet entries are provided only for performance tests in which calculations are required to obtain the test results.

2. RF Output Level Accuracy and Flatness Test

Flatness Test (E5070A and E5071A)

Frequency [Hz]	Power meter reading [dBm]		Test result equation
	[a]	[REF]	
50 M	_____		
10 M		_____	a - REF
550 M		_____	a - REF
1.05 G		_____	a - REF
1.55 G		_____	a - REF
2.05 G		_____	a - REF
3.00 G		_____	a - REF

(E5071A only)

Frequency [Hz]	Power meter reading [dBm]		Test result equation
	[a]	[REF]	
4.25 G		_____	a - REF
5.05 G		_____	a - REF
6.05 G		_____	a - REF
7.05 G		_____	a - REF
8.05 G		_____	a - REF
8.5 G		_____	a - REF

3. RF Output Level Linearity Test

NOTE

Make a copy of the following calculation sheet for each combination of the test frequencies listed below:

E5070A: 10 MHz and 3 GHz

E5071A: 10 MHz and 3 GHz, 4.25 GHz and 8.5 GHz

CW frequency: _____ Hz

Power level [dBm]	Power meter reading [dBm]		Test result equation
	[a]	REF	
0	_____		
-1		_____	a-REF
-2		_____	a-REF
-3		_____	a-REF
-4		_____	a-REF
-5		_____	a-REF
-6		_____	a-REF
-7		_____	a-REF
-8		_____	a-REF
-9		_____	a-REF
-10		_____	a-REF
-11		_____	a-REF
-12		_____	a-REF
-13		_____	a-REF
-14		_____	a-REF
-15		_____	a-REF

CW frequency: _____ Hz

Power level [dBm]	Power meter reading [dBm]		Test result equation
	[a]	REF	
0	_____		
-1		_____	a-REF
-2		_____	a-REF

Power level [dBm]	Power meter reading [dBm]		Test result equation
	[a]	REF	
-3		_____	a-REF
-4		_____	a-REF
-5		_____	a-REF
-6		_____	a-REF
-7		_____	a-REF
-8		_____	a-REF
-9		_____	a-REF
-10		_____	a-REF
-11		_____	a-REF
-12		_____	a-REF
-13		_____	a-REF
-14		_____	a-REF
-15		_____	a-REF

2. Performance Test

Performance Tests
E5070A/E5071A Performance Test Calculation Sheet

4. Trace Noise CW Test

NOTE

Make a copy of the following calculation sheet for each combination of the S-parameters Listed below:

Option 212/213: S21 and S12

Option 313/314: S21 and S12, S23 and S32

Option 413/414: S21 and S12, S43 and S34

(One calculation sheet can cover 2 parameters.)

S-parameter: _____ (E5070A and E5071A)

CW frequency [Hz]	s.dev [μ U]	Trace noise level [dB rms]	Test result equation
3 MHz			Trace noise level = 20 log (1 + s.dev $\times 10^{-3}$)
1.3 GHz			
2.1 GHz			
3 GHz			

(E5071A only)

CW frequency [Hz]	s.dev [μ U]	Trace noise level [dB rms]	Test result equation
4.25 GHz			Trace noise level = 20 log (1 + s.dev $\times 10^{-3}$)
7.5 GHz			
8.5 GHz			

S-parameter: _____ (E5070A and E5071A)

CW frequency [Hz]	s.dev [μ U]	Trace noise level [dB rms]	Test result equation
3 MHz			Trace noise level = 20 log (1 + s.dev $\times 10^{-3}$)
1.3 GHz			
2.1 GHz			
3 GHz			

(E5071A only)

CW frequency [Hz]	s.dev [μ U]	Trace noise level [dB rms]	Test result equation
4.25 GHz			Trace noise level = 20 log (1 + s.dev $\times 10^{-3}$)
7.5 GHz			
8.5 GHz			

7. Dynamic Accuracy Test

Make a copy of the following calculation sheet for each of the S-parameters listed below:

Option 213 and 214: S21 and S12

Option 313 and 314: S21, S12 and S31

Option 413 and 414: S21, S12, S31 and S41

NOTE

A dynamic accuracy calculation example is shown at the end of the calculation sheets.

S-Parameter: _____ (-20 dBm to -110 dBm)

Name	A1	A2	Power setting [dB]	Pm [dB]	Sxy [dB] @ Port Char ON	R [dB]@ Port Char OFF	Sxy × R [dB]	Running D.A.	True D.A.
DA20	0	20						REF	REF
DA25	5	20						_____	_____
(Sxy × R @ DA25) - (Sxy × R @ DA20) - (Pm @ DA25) + (Pm @ DA20) →									
DA30	10	20						_____	_____
(Sxy × R @ DA30) - (Sxy × R @ DA20) - (Pm @ DA30) + (Pm @ DA20) →									
DA30a	0	30						_____	_____
Adjust source power for (Pm [db] @ DA30a) - (Sxy × R [dB] @ DA30a) + (Sxy × R [dB] @ DA30)									
DA30b	0	30						REF30	REF30
DA35	5	30						_____	_____
(Sxy × R @ DA35) - (Sxy × R @ DA30b) - (Pm @ DA35) + (Pm @ DA30b) → True D.A. = (Running D.A. [dB] @ DA35) + (True D.A. [dB] @ DA30)									
								_____	_____
DA40	10	30						_____	_____
(Sxy × R @ DA40) - (Sxy × R @ DA30b) - (Pm @ DA40) + (Pm @ DA30b) → True D.A. = (Running D.A. [dB] @ DA40) + (True D.A. [dB] @ DA30)									
DA40a	0	40						_____	_____
Adjust source power for (Pm [db] @ DA40a) - (Sxy × R [dB] @ DA40a) + (Sxy × R [dB] @ DA40)									
DA40b	0	40						REF40	REF40
DA45	5	40						_____	_____
(Sxy × R @ DA45) - (Sxy × R @ DA40b) - (Pm @ DA45) + (Pm @ DA40b) → True D.A. = (Running D.A. [dB] @ DA45) + (True D.A. [dB] @ DA40)									
DA50	10	40						_____	_____
(Sxy × R @ DA50) - (Sxy × R @ DA40b) - (Pm @ DA50) + (Pm @ DA40b) → True D.A. = (Running D.A. [dB] @ DA50) + (True D.A. [dB] @ DA40)									

2. Performance Test

Performance Tests
E5070A/E5071A Performance Test Calculation Sheet

Name	A1	A2	Power setting [dB]	Pm [dB]	Sxy [dB] @ Port Char ON	R [dB]@ Port Char OFF	Sxy × R [dB]	Running D.A.	True D.A.
DA50a	0	50						_____	_____
Adjust source power for (Pm [db] @ DA50a) - (Sxy × R [dB] @ DA50a) + (Sxy × R [dB] @ DA50)									
DA50b	0	50						REF50	REF50
DA55	5	50						_____	_____
	(Sxy × R @ DA55) - (Sxy × R @ DA50b) - (Pm @ DA55) + (Pm @ DA50b) → True D.A. = (Running D.A. [dB] @ DA55) + (True D.A. [dB] @ DA50)								
DA60	10	50						_____	_____
	(Sxy × R @ DA60) - (Sxy × R @ DA50b) - (Pm @ DA60) + (Pm @ DA50b) → True D.A. = (Running D.A. [dB] @ DA60) + (True D.A. [dB] @ DA50)								
DA60a	0	60						_____	_____
Adjust source power for (Pm [db] @ DA60a) - (Sxy × R [dB] @ DA60a) + (Sxy × R [dB] @ DA60)									
DA60b	0	60						REF60	REF60
DA65	5	60						_____	_____
	(Sxy × R @ DA65) - (Sxy × R @ DA60b) - (Pm @ DA65) + (Pm @ DA60b) → True D.A. = (Running D.A. [dB] @ DA65) + (True D.A. [dB] @ DA60)								
DA70	10	60						_____	_____
	(Sxy × R @ DA70) - (Sxy × R @ DA60b) - (Pm @ DA70) + (Pm @ DA60b) → True D.A. = (Running D.A. [dB] @ DA70) + (True D.A. [dB] @ DA60)								
DA70a	0	70						_____	_____
Adjust source power for (Pm [db] @ DA70a) - (Sxy × R [dB] @ DA70a) + (Sxy × R [dB] @ DA70)									
DA70b	0	70						REF70	REF70
DA75	5	70						_____	_____
	(Sxy × R @ DA75) - (Sxy × R @ DA70b) - (Pm @ DA75) + (Pm @ DA70b) → True D.A. = (Running D.A. [dB] @ DA75) + (True D.A. [dB] @ DA70)								
DA80	10	70						_____	_____
	(Sxy × R @ DA80) - (Sxy × R @ DA70b) - (Pm @ DA80) + (Pm @ DA70b) → True D.A. = (Running D.A. [dB] @ DA80) + (True D.A. [dB] @ DA70)								
DA80a	0	80						_____	_____
Adjust source power for (Pm [db] @ DA80a) - (Sxy × R [dB] @ DA80a) + (Sxy × R [dB] @ DA80)									
DA80b	0	80						REF80	REF80
DA85	5	80						_____	_____
	(Sxy × R @ DA85) - (Sxy × R @ DA80b) - (Pm @ DA85) + (Pm @ DA80b) → True D.A. = (Running D.A. [dB] @ DA85) + (True D.A. [dB] @ DA80)								
DA90	10	80						_____	_____

Performance Tests
E5070A/E5071A Performance Test Calculation Sheet

Name	A1	A2	Power setting [dB]	Pm [dB]	Sxy [dB] @ Port Char ON	R [dB]@ Port Char OFF	Sxy × R [dB]	Running D.A.	True D.A.
$(Sxy \times R @ DA90) - (Sxy \times R @ DA80b) - (Pm @ DA90) + (Pm @ DA80b) \rightarrow$ True D.A. = (Running D.A. [dB] @ DA90) + (True D.A. [dB] @ DA80)									
DA90a	0	90						_____	_____
Adjust source power for (Pm [db] @ DA90a) - (Sxy × R [dB] @ DA90a) + (Sxy × R [dB] @ DA90)									
DA90b	0	90						REF90	REF90
DA95	5	90						_____	_____
$(Sxy \times R @ DA95) - (Sxy \times R @ DA90b) - (Pm @ DA95) + (Pm @ DA90b) \rightarrow$ True D.A. = (Running D.A. [dB] @ DA95) + (True D.A. [dB] @ DA90)									
DA100	10	90						_____	_____
$(Sxy \times R @ DA100) - (Sxy \times R @ DA90b) - (Pm @ DA100) + (Pm @ DA90b)$ True D.A. = (Running D.A. [dB] @ DA100) + (True D.A. [dB] @ DA90)									
DA100a	0	100						_____	_____
Adjust source power for (Pm [db] @ DA100a) - (Sxy × R [dB] @ DA100a) + (Sxy × R [dB] @ DA100)									
DA100b	0	100						REF100	REF100
DA105	5	100						_____	_____
$(Sxy \times R @ DA105) - (Sxy \times R @ DA100b) - (Pm @ DA105) + (Pm @ DA100b) \rightarrow$ True D.A. = (Running D.A. [dB] @ DA105) + (True D.A. [dB] @ DA100)									
DA110	10	100						_____	_____
$(Sxy \times R @ DA110) - (Sxy \times R @ DA100b) - (Pm @ DA110) + (Pm @ DA100b) \rightarrow$ True D.A. = (Running D.A. [dB] @ DA110) + (True D.A. [dB] @ DA100)									
DA20	10	10						REF10	REF10
DA15	5	10						_____	_____
$(Sxy \times R @ DA15) - (Sxy \times R @ DA20) - (Pm @ DA15) + (Pm @ DA20)$									
DA10	0	10						_____	_____
$(Sxy \times R @ DA10) - (Sxy \times R @ DA20) - (Pm @ DA10) + (Pm @ DA20) \rightarrow$									
DA10a	10	0						_____	_____
Adjust source power for (Pm [db] @ DA10a) - (Sxy × R [dB] @ DA10a) + (Sxy × R [dB] @ DA10)									
DA10b	10	0						REF0	REF0
DA5	5	0						_____	_____
$(Sxy \times R @ DA5) - (Sxy \times R @ DA10b) - (Pm @ DA5) + (Pm @ DA10b) \rightarrow$ True D.A. = (Running D.A. [dB] @ DA5) + (True D.A. [dB] @ DA10)									
DA0	0	0						_____	_____
$(Sxy \times R @ DA0) - (Sxy \times R @ DA10b) - (Pm @ DA0) + (Pm @ DA10b) \rightarrow$ True D.A. = (Running D.A. [dB] @ DA0) + (True D.A. [dB] @ DA10)									

2. Performance Test

E5070A Performance Test Record

Agilent Technologies E5070A RF Network Analyzer

Serial Number:		Option:	
Temperature:	°C	Test Date:	
Humidity:	% R.H.	Tested by:	

Frequency Accuracy Test

Without Option 1E5

Frequency [Hz]	Test limit [Hz]	Test result [Hz]	Measurement uncertainty [Hz]
50 M	± 250		± 11
3 G	± 15 k	k	± 0.64 k

With Option 1E5

Frequency [Hz]	Test limit [Hz]	Test result [Hz]	Measurement uncertainty [Hz]
50 M	± 50		± 11
3 G	± 3.00 k	k	± 0.64 k

RF Output Level Accuracy and Flatness Test

Level Accuracy Test (@ Port 1)

Power level [dBm]	Frequency [Hz]	Test limit [dB]	Test result [dB]	Measurement uncertainty [dB]
0	50 M	± 0.65		± 0.13

Level Flatness Test (@ Port 1) (at 0dBm, relative to 50 MHz reference)

Frequency [Hz]	Test limit [dB]	Test result [dB]	Measurement uncertainty [dB]
10 M	± 1.0		± 0.30
550 M	± 1.0		± 0.14
1.05 G	± 1.0		± 0.14
1.55 G	± 1.0		± 0.14

Frequency [Hz]	Test limit [dB]	Test result [dB]	Measurement uncertainty [dB]
2.05 G	± 1.0		± 0.16
3.00 G	± 1.0		± 0.16

RF Output Level Linearity Test (@ Port1)

CW Frequency: 10 MHz (relative to 0 dBm reference)

Power level [dBm]	Test limit [dB]	Test result [dB]	Measurement uncertainty [dB]
-1	± 0.75		± 0.17
-2	± 0.75		± 0.17
-3	± 0.75		± 0.17
-4	± 0.75		± 0.17
-5	± 0.75		± 0.17
-6	± 0.75		± 0.17
-7	± 0.75		± 0.17
-8	± 0.75		± 0.17
-9	± 0.75		± 0.17
-10	± 0.75		± 0.17
-11	± 0.75		± 0.17
-12	± 0.75		± 0.17
-13	± 0.75		± 0.17
-14	± 0.75		± 0.17
-15	± 0.75		± 0.17

CW Frequency: 3 GHz (relative to 0 dBm reference)

Power level [dBm]	Test limit [dB]	Test result [dB]	Measurement uncertainty [dB]
-1	± 0.75		± 0.17
-2	± 0.75		± 0.17
-3	± 0.75		± 0.17
-4	± 0.75		± 0.17
-5	± 0.75		± 0.17

Performance Tests
E5070A Performance Test Record

Power level [dBm]	Test limit [dB]	Test result [dB]	Measurement uncertainty [dB]
-6	± 0.75		± 0.17
-7	± 0.75		± 0.17
-8	± 0.75		± 0.17
-9	± 0.75		± 0.17
-10	± 0.75		± 0.17
-11	± 0.75		± 0.17
-12	± 0.75		± 0.17
-13	± 0.75		± 0.17
-14	± 0.75		± 0.17
-15	± 0.75		± 0.17

Trace Noise CW Test (Magnitude)

Direction: S21

CW frequency [Hz]	IF bandwidth [Hz]	Test limit [dB rms]	Test result [dB rms]
3 M	3 k	< 0.001	
1.3 G	3 k	< 0.001	
2.1 G	3 k	< 0.001	
3 G	3 k	< 0.001	

Direction: S12

CW frequency [Hz]	IF bandwidth [Hz]	Test limit [dB rms]	Test result [dB rms]
3 M	3 k	< 0.001	
1.3 G	3 k	< 0.001	
2.1 G	3 k	< 0.001	
3 G	3 k	< 0.001	

Direction: S23 (Option 313 and 314 only)

CW frequency [Hz]	IF bandwidth [Hz]	Test limit [dB rms]	Test result [dB rms]
3 M	3 k	< 0.001	
1.3 G	3 k	< 0.001	
2.1 G	3 k	< 0.001	
3 G	3 k	< 0.001	

Direction: S32 (Option 313 and 314 only)

CW frequency [Hz]	IF bandwidth [Hz]	Test limit [dB rms]	Test result [dB rms]
3 M	3 k	< 0.001	
1.3 G	3 k	< 0.001	
2.1 G	3 k	< 0.001	
3 G	3 k	< 0.001	

Direction: S43 (Option 413 and 414 only)

CW frequency [Hz]	IF bandwidth [Hz]	Test limit [dB rms]	Test result [dB rms]
3 M	3 k	< 0.001	
1.3 G	3 k	< 0.001	
2.1 G	3 k	< 0.001	
3 G	3 k	< 0.001	

Direction: S34 (Option 413 and 414 only)

CW frequency [Hz]	IF bandwidth [Hz]	Test limit [dB rms]	Test result [dB rms]
3 M	3 k	< 0.001	
1.3 G	3 k	< 0.001	
2.1 G	3 k	< 0.001	
3 G	3 k	< 0.001	

Crosstalk Test

Direction: S21 (Options 213, 214, 313 and 314 only)

Frequency range [Hz]	IF bandwidth [Hz]	Test limit [dB]	Test result [dB]
3 M - 3 G	10	< -120	

Direction: S12 (Options 213, 214, 313 and 314 only)

Frequency range [Hz]	IF bandwidth [Hz]	Test limit [dB]	Test result [dB]
3 M - 3 G	10	< -120	

Direction: S32 (Options 313, 314, 413 and 414 only)

Frequency range [Hz]	IF bandwidth [Hz]	Test limit [dB]	Test result [dB]
3 M - 3 G	10	< -120	

Direction: S23 (Options 313, 314, 413 and 414 only)

Frequency range [Hz]	IF bandwidth [Hz]	Test limit [dB]	Test result [dB]
3 M - 3 G	10	< -120	

Direction: S41 (Options 413 and 414 only)

Frequency range [Hz]	IF bandwidth [Hz]	Test limit [dB]	Test result [dB]
3 M - 3 G	10	< -120	

Direction: S14 (Options 413 and 414 only)

Frequency range [Hz]	IF bandwidth [Hz]	Test limit [dB]	Test result [dB]
3 M - 3 G	10	< -120	

System Dynamic Range Test

Direction: S21 (Options 213, 214, 313 and 314 only)

Frequency range [Hz]	IF bandwidth [Hz]	Test limit [dB]	Test result [dB]
3 M - 1.5 G	10	< -120	
1.5 G - 3 G	10	< -122	
3 M - 1.5 G	3 k	< -95	
1.5 G - 3 G	3 k	< -97	

Direction: S12 (Options 213, 214, 313 and 314 only)

Frequency range [Hz]	IF bandwidth [Hz]	Test limit [dB]	Test result [dB]
3 M - 1.5 G	10	< -120	
1.5 G - 3 G	10	< -122	
3 M - 1.5 G	3 k	< -95	
1.5 G - 3 G	3 k	< -97	

Direction: S32 (Options 313, 314, 413, 414 only)

Frequency range [Hz]	IF bandwidth [Hz]	Test limit [dB]	Test result [dB]
3 M - 1.5 G	10	< -120	
1.5 G - 3 G	10	< -122	
3 M - 1.5 G	3 k	< -95	
1.5 G - 3 G	3 k	< -97	

Direction: S23 (Options 313, 314, 413 and 414 only)

Frequency range [Hz]	IF bandwidth [Hz]	Test limit [dB]	Test result [dB]
3 M - 1.5 G	10	< -120	
1.5 G - 3 G	10	< -122	
3 M - 1.5 G	3 k	< -95	
1.5 G - 3 G	3 k	< -97	

Direction: S41 (Options 413 and 414 only)

Frequency range [Hz]	IF bandwidth [Hz]	Test limit [dB]	Test result [dB]
3 M - 1.5 G	10	< -120	
1.5 G - 3 G	10	< -122	
3 M - 1.5 G	3 k	< -95	
1.5 G - 3 G	3 k	< -97	

Direction: S14 (Options 413 and 414 only)

Frequency range [Hz]	IF bandwidth [Hz]	Test limit [dB]	Test result [dB]
3 M - 1.5 G	10	< -120	
1.5 G - 3 G	10	< -122	
3 M - 1.5 G	3 k	< -95	

Performance Tests
E5070A Performance Test Record

Frequency range [Hz]	IF bandwidth [Hz]	Test limit [dB]	Test result [dB]
1.5 G - 3 G	3 k	< -97	

Dynamic Accuracy Test

@ Reference power level: -20 dBm

Direction: S21

Power level [dBm]	Test limit [dB]	Test result [dB]	Measurement uncertainty [dB]
0	± 0.207		± 0.015
-5	± 0.075		± 0.015
-10	± 0.042		± 0.012
-15	± 0.031		± 0.012
-25	± 0.030		± 0.0087
-30	± 0.035		± 0.0087
-35	± 0.040		± 0.012
-40	± 0.045		± 0.012
-45	± 0.056		± 0.015
-50	± 0.067		± 0.015
-55	± 0.078		± 0.017
-60	± 0.091		± 0.017
-65	± 0.106		± 0.019
-70	± 0.125		± 0.019
-75	± 0.151		± 0.021
-80	± 0.189		± 0.021
-85	± 0.248		± 0.023
-90	± 0.346		± 0.023
-95	± 0.509		± 0.024
-100	± 0.785		± 0.024
-105	± 1.248		± 0.026
-110	± 2.008		± 0.026

Direction: S12

Power level [dBm]	Test limit [dB]	Test result [dB]	Measurement uncertainty [dB]
0	± 0.207		± 0.015
-5	± 0.075		± 0.015
-10	± 0.042		± 0.012
-15	± 0.031		± 0.012
-25	± 0.030		± 0.0087
-30	± 0.035		± 0.0087
-35	± 0.040		± 0.012
-40	± 0.045		± 0.012
-45	± 0.056		± 0.015
-50	± 0.067		± 0.015
-55	± 0.078		± 0.017
-60	± 0.091		± 0.017
-65	± 0.106		± 0.019
-70	± 0.125		± 0.019
-75	± 0.151		± 0.021
-80	± 0.189		± 0.021
-85	± 0.248		± 0.023
-90	± 0.346		± 0.023
-95	± 0.509		± 0.024
-100	± 0.785		± 0.024
-105	± 1.248		± 0.026
-110	± 2.008		± 0.026

Direction: S31 (Options 313, 314, 413 and 414 only)

Power level [dBm]	Test limit [dB]	Test result [dB]	Measurement uncertainty [dB]
0	± 0.207		± 0.015
-5	± 0.075		± 0.015
-10	± 0.042		± 0.012
-15	± 0.031		± 0.012

Performance Tests
E5070A Performance Test Record

Power level [dBm]	Test limit [dB]	Test result [dB]	Measurement uncertainty [dB]
-25	± 0.030		± 0.0087
-30	± 0.035		± 0.0087
-35	± 0.040		± 0.012
-40	± 0.045		± 0.012
-45	± 0.056		± 0.015
-50	± 0.067		± 0.015
-55	± 0.078		± 0.017
-60	± 0.091		± 0.017
-65	± 0.106		± 0.019
-70	± 0.125		± 0.019
-75	± 0.151		± 0.021
-80	± 0.189		± 0.021
-85	± 0.248		± 0.023
-90	± 0.346		± 0.023
-95	± 0.509		± 0.024
-100	± 0.785		± 0.024
-105	± 1.248		± 0.026
-110	± 2.008		± 0.026

Direction: S41 (Options 413 and 414 only)

Power level [dBm]	Test limit [dB]	Test result [dB]	Measurement uncertainty [dB]
0	± 0.207		± 0.015
-5	± 0.075		± 0.015
-10	± 0.042		± 0.012
-15	± 0.031		± 0.012
-25	± 0.030		± 0.0087
-30	± 0.035		± 0.0087
-35	± 0.040		± 0.012
-40	± 0.045		± 0.012

Power level [dBm]	Test limit [dB]	Test result [dB]	Measurement uncertainty [dB]
-45	± 0.056		± 0.015
-50	± 0.067		± 0.015
-55	± 0.078		± 0.017
-60	± 0.091		± 0.017
-65	± 0.106		± 0.019
-70	± 0.125		± 0.019
-75	± 0.151		± 0.021
-80	± 0.189		± 0.021
-85	± 0.248		± 0.023
-90	± 0.346		± 0.023
-95	± 0.509		± 0.024
-100	± 0.785		± 0.024
-105	± 1.248		± 0.026
-110	± 2.008		± 0.026

Uncorrected System Performance Test

Port 1

System performance	Frequency range [Hz]	Test limit [dB]	Test result [dB]
Directivity	3 M - 3 G	< -10	
Source match	3 M - 3 G	< -15	
Load match	3 M - 3 G	< -17	

Port 2

System performance	Frequency range [Hz]	Test limit [dB]	Test result [dB]
Directivity	3 M - 3 G	< -10	
Source match	3 M - 3 G	< -15	
Load match	3 M - 3 G	< -17	

Performance Tests
E5070A Performance Test Record

Port 3 (Options 313, 314, 413 and 414 only)

System performance	Frequency range [Hz]	Test limit [dB]	Test result [dB]
Directivity	3 M - 3 G	< -10	
Source match	3 M - 3 G	< -15	
Load match	3 M - 3 G	< -17	

Port 4 (Options 413 and 414 only)

System performance	Frequency range [Hz]	Test limit [dB]	Test result [dB]
Directivity	3 M - 3 G	< -10	
Source match	3 M - 3 G	< -15	
Load match	3 M - 3 G	< -17	

E5071A Performance Test Record

Agilent Technologies E5071A RF Network Analyzer

Serial Number:		Option:	
Temperature:	°C	Test Date:	
Humidity:	% R.H.	Tested by:	

Frequency Accuracy Test

Without Option 1E5

Frequency [Hz]	Test limit [Hz]	Test result [Hz]	Measurement uncertainty [Hz]
50 M	± 250		± 11
3 G	± 15 k	k	± 0.64 k

With Option 1E5

Frequency [Hz]	Test limit [Hz]	Test result [Hz]	Measurement uncertainty [Hz]
50 M	± 50		± 11
3 G	± 3.00 k	k	± 0.64 k

RF Output Level Accuracy and Flatness Test

Level Accuracy Test (@ Port 1)

Power level [dBm]	Frequency [Hz]	Test limit [dB]	Test result [dB]	Measurement uncertainty [dB]
0	50 M	± 0.65		± 0.13

Level Flatness Test (@ Port 1) (at 0dBm, relative to 50 MHz reference)

Frequency [Hz]	Test limit [dB]	Test result [dB]	Measurement uncertainty [dB]
10 M	± 1.0		± 0.30
550 M	± 1.0		± 0.14
1.05 G	± 1.0		± 0.14
1.55 G	± 1.0		± 0.14

Performance Tests
E5071A Performance Test Record

Frequency [Hz]	Test limit [dB]	Test result [dB]	Measurement uncertainty [dB]
2.05 G	± 1.0		± 0.16
3.00 G	± 1.0		± 0.16
4.25 G	± 1.0		± 0.21
5.05 G	± 1.0		± 0.21
6.05 G	± 1.0		± 0.26
7.05 G	± 1.0		± 0.26
8.05 G	± 1.0		± 0.26
8.50 G	± 1.0		± 0.26

RF Output Level Linearity Test (@ Port1)

CW Frequency: 10 MHz (relative to 0 dBm reference)

Power level [dBm]	Test limit [dB]	Test result [dB]	Measurement uncertainty [dB]
-1	± 0.75		± 0.17
-2	± 0.75		± 0.17
-3	± 0.75		± 0.17
-4	± 0.75		± 0.17
-5	± 0.75		± 0.17
-6	± 0.75		± 0.17
-7	± 0.75		± 0.17
-8	± 0.75		± 0.17
-9	± 0.75		± 0.17
-10	± 0.75		± 0.17
-11	± 0.75		± 0.17
-12	± 0.75		± 0.17
-13	± 0.75		± 0.17
-14	± 0.75		± 0.17
-15	± 0.75		± 0.17

CW Frequency: 3 GHz (relative to 0 dBm reference)

Power level [dBm]	Test limit [dB]	Test result [dB]	Measurement uncertainty [dB]
-1	± 0.75		± 0.17
-2	± 0.75		± 0.17
-3	± 0.75		± 0.17
-4	± 0.75		± 0.17
-5	± 0.75		± 0.17
-6	± 0.75		± 0.17
-7	± 0.75		± 0.17
-8	± 0.75		± 0.17
-9	± 0.75		± 0.17
-10	± 0.75		± 0.17
-11	± 0.75		± 0.17
-12	± 0.75		± 0.17
-13	± 0.75		± 0.17
-14	± 0.75		± 0.17
-15	± 0.75		± 0.17

CW Frequency: 4.25 GHz (relative to 0 dBm reference)

Power level [dBm]	Test limit [dB]	Test result [dB]	Measurement uncertainty [dB]
-1	± 1.5		± 0.17
-2	± 1.5		± 0.17
-3	± 1.5		± 0.17
-4	± 1.5		± 0.17
-5	± 1.5		± 0.17
-6	± 1.5		± 0.17
-7	± 1.5		± 0.17
-8	± 1.5		± 0.17
-9	± 1.5		± 0.17
-10	± 1.5		± 0.17
-11	± 3.0		± 0.17

2. Performance Test

Performance Tests
E5071A Performance Test Record

Power level [dBm]	Test limit [dB]	Test result [dB]	Measurement uncertainty [dB]
-12	± 3.0		± 0.17
-13	± 3.0		± 0.17
-14	± 3.0		± 0.17
-15	± 3.0		± 0.17

CW Frequency: 8.5 GHz (relative to 0 dBm reference)

Power level [dBm]	Test limit [dB]	Test result [dB]	Measurement uncertainty [dB]
-1	± 1.5		± 0.17
-2	± 1.5		± 0.17
-3	± 1.5		± 0.17
-4	± 1.5		± 0.17
-5	± 1.5		± 0.17
-6	± 1.5		± 0.17
-7	± 1.5		± 0.17
-8	± 1.5		± 0.17
-9	± 1.5		± 0.17
-10	± 1.5		± 0.17
-11	± 3.0		± 0.17
-12	± 3.0		± 0.17
-13	± 3.0		± 0.17
-14	± 3.0		± 0.17
-15	± 3.0		± 0.17

Trace Noise CW Test (Magnitude)

Direction: S21

CW frequency [Hz]	IF bandwidth [Hz]	Test limit [dB rms]	Test result [dB rms]
3 M	3 k	< 0.001	
1.3 G	3 k	< 0.001	
2.1 G	3 k	< 0.001	

CW frequency [Hz]	IF bandwidth [Hz]	Test limit [dB rms]	Test result [dB rms]
3 G	3 k	< 0.001	
4.25 G	3 k	< 0.003	
7.5 G	3 k	< 0.003	
8.5 G	3 k	< 0.005	

Direction: S12

CW frequency [Hz]	IF bandwidth [Hz]	Test limit [dB rms]	Test result [dB rms]
3 M	3 k	< 0.001	
1.3 G	3 k	< 0.001	
2.1 G	3 k	< 0.001	
3 G	3 k	< 0.001	
4.25 G	3 k	< 0.003	
7.5 G	3 k	< 0.003	
8.5 G	3 k	< 0.005	

Direction: S23 (Option 313 and 314 only)

CW frequency [Hz]	IF bandwidth [Hz]	Test limit [dB rms]	Test result [dB rms]
3 M	3 k	< 0.001	
1.3 G	3 k	< 0.001	
2.1 G	3 k	< 0.001	
3 G	3 k	< 0.001	
4.25 G	3 k	< 0.003	
7.5 G	3 k	< 0.003	
8.5 G	3 k	< 0.005	

Direction: S32 (Option 313 and 314 only)

CW frequency [Hz]	IF bandwidth [Hz]	Test limit [dB rms]	Test result [dB rms]
3 M	3 k	< 0.001	
1.3 G	3 k	< 0.001	

Performance Tests
E5071A Performance Test Record

CW frequency [Hz]	IF bandwidth [Hz]	Test limit [dB rms]	Test result [dB rms]
2.1 G	3 k	< 0.001	
3 G	3 k	< 0.001	
4.25 G	3 k	< 0.003	
7.5 G	3 k	< 0.003	
8.5 G	3 k	< 0.005	

Direction: S43 (Option 413 and 414 only)

CW frequency [Hz]	IF bandwidth [Hz]	Test limit [dB rms]	Test result [dB rms]
3 M	3 k	< 0.001	
1.3 G	3 k	< 0.001	
2.1 G	3 k	< 0.001	
3 G	3 k	< 0.001	
4.25 G	3 k	< 0.003	
7.5 G	3 k	< 0.003	
8.5 G	3 k	< 0.005	

Direction: S34 (Option 413 and 414 only)

CW frequency [Hz]	IF bandwidth [Hz]	Test limit [dB rms]	Test result [dB rms]
3 M	3 k	< 0.001	
1.3 G	3 k	< 0.001	
2.1 G	3 k	< 0.001	
3 G	3 k	< 0.001	
4.25 G	3 k	< 0.003	
7.5 G	3 k	< 0.003	
8.5 G	3 k	< 0.005	

Crosstalk Test

Direction: S21 (Options 213, 214, 313 and 314 only)

Frequency range [Hz]	IF bandwidth [Hz]	Test limit [dB]	Test result [dB]
3 M - 3 G	10	< -120	
3 G - 6 G	10	< -110	
6 G - 7.5 G	10	< -100	
7.5 G - 8.5 G	10	< -90	

Direction: S12 (Options 213, 214, 313 and 314 only)

Frequency range [Hz]	IF bandwidth [Hz]	Test limit [dB]	Test result [dB]
3 M - 3 G	10	< -120	
3 G - 6 G	10	< -110	
6 G - 7.5 G	10	< -100	
7.5 G - 8.5 G	10	< -90	

Direction: S32 (Options 313, 314, 413 and 414 only)

Frequency range [Hz]	IF bandwidth [Hz]	Test limit [dB]	Test result [dB]
3 M - 3 G	10	< -120	
3 G - 6 G	10	< -110	
6 G - 7.5 G	10	< -100	
7.5 G - 8.5 G	10	< -90	

Direction: S23 (Options 313, 314, 413 and 414 only)

Frequency range [Hz]	IF bandwidth [Hz]	Test limit [dB]	Test result [dB]
3 M - 3 G	10	< -120	
3 G - 6 G	10	< -110	
6 G - 7.5 G	10	< -100	
7.5 G - 8.5 G	10	< -90	

Direction: S41 (Options 413 and 414 only)

Frequency range [Hz]	IF bandwidth [Hz]	Test limit [dB]	Test result [dB]
3 M - 3 G	10	< -120	
3 G - 6 G	10	< -110	

Performance Tests
E5071A Performance Test Record

Frequency range [Hz]	IF bandwidth [Hz]	Test limit [dB]	Test result [dB]
6 G - 7.5 G	10	< -100	
7.5 G - 8.5 G	10	< -90	

Direction: S14 (Options 413 and 414 only)

Frequency range [Hz]	IF bandwidth [Hz]	Test limit [dB]	Test result [dB]
3 M - 3 G	10	< -120	
3 G - 6 G	10	< -110	
6 G - 7.5 G	10	< -100	
7.5 G - 8.5 G	10	< -90	

System Dynamic Range Test

Direction: S21 (Options 213, 214, 313 and 314 only)

Frequency range [Hz]	IF bandwidth [Hz]	Test limit [dB]	Test result [dB]
3 M - 1.5 G	10	< -120	
1.5 G - 4 G	10	< -122	
4 G - 6 G	10	< -120	
6 G - 7.5 G	10	< -117	
7.5 G - 8.5 G	10	< -110	
3 M - 1.5 G	3 k	< -95	
1.5 G - 4 G	3 k	< -97	
4 G - 6 G	3 k	< -95	
6 G - 7.5 G	3 k	< -92	
7.5 G - 8.5 G	3 k	< -85	

Direction: S12 (Options 213, 214, 313 and 314 only)

Frequency range [Hz]	IF bandwidth [Hz]	Test limit [dB]	Test result [dB]
3 M - 1.5 G	10	< -120	
1.5 G - 4 G	10	< -122	
4 G - 6 G	10	< -120	
6 G - 7.5 G	10	< -117	
7.5 G - 8.5 G	10	< -110	

Frequency range [Hz]	IF bandwidth [Hz]	Test limit [dB]	Test result [dB]
3 M - 1.5 G	3 k	< -95	
1.5 G - 4 G	3 k	< -97	
4 G - 6 G	3 k	< -95	
6 G - 7.5 G	3 k	< -92	
7.5 G - 8.5 G	3 k	< -85	

Direction: S32 (Options 313, 314, 413, 414 only)

Frequency range [Hz]	IF bandwidth [Hz]	Test limit [dB]	Test result [dB]
3 M - 1.5 G	10	< -120	
1.5 G - 4 G	10	< -122	
4 G - 6 G	10	< -120	
6 G - 7.5 G	10	< -117	
7.5 G - 8.5 G	10	< -110	
3 M - 1.5 G	3 k	< -95	
1.5 G - 4 G	3 k	< -97	
4 G - 6 G	3 k	< -95	
6 G - 7.5 G	3 k	< -92	
7.5 G - 8.5 G	3 k	< -85	

Direction: S23 (Options 313, 314, 413 and 414 only)

Frequency range [Hz]	IF bandwidth [Hz]	Test limit [dB]	Test result [dB]
3 M - 1.5 G	10	< -120	
1.5 G - 4 G	10	< -122	
4 G - 6 G	10	< -120	
6 G - 7.5 G	10	< -117	
7.5 G - 8.5 G	10	< -110	
3 M - 1.5 G	3 k	< -95	
1.5 G - 4 G	3 k	< -97	
4 G - 6 G	3 k	< -95	
6 G - 7.5 G	3 k	< -92	
7.5 G - 8.5 G	3 k	< -85	

Performance Tests
E5071A Performance Test Record

Direction: S41 (Options 413 and 414 only)

Frequency range [Hz]	IF bandwidth [Hz]	Test limit [dB]	Test result [dB]
3 M - 1.5 G	10	< -120	
1.5 G - 4 G	10	< -122	
4 G - 6 G	10	< -120	
6 G - 7.5 G	10	< -117	
7.5 G - 8.5 G	10	< -110	
3 M - 1.5 G	3 k	< -95	
1.5 G - 4 G	3 k	< -97	
4 G - 6 G	3 k	< -95	
6 G - 7.5 G	3 k	< -92	
7.5 G - 8.5 G	3 k	< -85	

Direction: S14 (Options 413 and 414 only)

Frequency range [Hz]	IF bandwidth [Hz]	Test limit [dB]	Test result [dB]
3 M - 1.5 G	10	< -120	
1.5 G - 4 G	10	< -122	
4 G - 6 G	10	< -120	
6 G - 7.5 G	10	< -117	
7.5 G - 8.5 G	10	< -110	
3 M - 1.5 G	3 k	< -95	
1.5 G - 4 G	3 k	< -97	
4 G - 6 G	3 k	< -95	
6 G - 7.5 G	3 k	< -92	
7.5 G - 8.5 G	3 k	< -85	

Dynamic Accuracy Test

@ Reference power level: -20 dBm

Direction: S21

Power level [dBm]	Test limit [dB]	Test result [dB]	Measurement uncertainty [dB]
0	± 0.207		± 0.015

Power level [dBm]	Test limit [dB]	Test result [dB]	Measurement uncertainty [dB]
-5	± 0.075		± 0.015
-10	± 0.042		± 0.012
-15	± 0.031		± 0.012
-25	± 0.030		± 0.0087
-30	± 0.035		± 0.0087
-35	± 0.040		± 0.012
-40	± 0.045		± 0.012
-45	± 0.056		± 0.015
-50	± 0.067		± 0.015
-55	± 0.078		± 0.017
-60	± 0.091		± 0.017
-65	± 0.106		± 0.019
-70	± 0.125		± 0.019
-75	± 0.151		± 0.021
-80	± 0.189		± 0.021
-85	± 0.248		± 0.023
-90	± 0.346		± 0.023
-95	± 0.509		± 0.024
-100	± 0.785		± 0.024
-105	± 1.248		± 0.026
-110	± 2.008		± 0.026

Direction: S12

Power level [dBm]	Test limit [dB]	Test result [dB]	Measurement uncertainty [dB]
0	± 0.207		± 0.015
-5	± 0.075		± 0.015
-10	± 0.042		± 0.012
-15	± 0.031		± 0.012
-25	± 0.030		± 0.0087

Performance Tests
E5071A Performance Test Record

Power level [dBm]	Test limit [dB]	Test result [dB]	Measurement uncertainty [dB]
-30	± 0.035		± 0.0087
-35	± 0.040		± 0.012
-40	± 0.045		± 0.012
-45	± 0.056		± 0.015
-50	± 0.067		± 0.015
-55	± 0.078		± 0.017
-60	± 0.091		± 0.017
-65	± 0.106		± 0.019
-70	± 0.125		± 0.019
-75	± 0.151		± 0.021
-80	± 0.189		± 0.021
-85	± 0.248		± 0.023
-90	± 0.346		± 0.023
-95	± 0.509		± 0.024
-100	± 0.785		± 0.024
-105	± 1.248		± 0.026
-110	± 2.008		± 0.026

Direction: S31 (Options 313, 314, 413 and 414 only)

Power level [dBm]	Test limit [dB]	Test result [dB]	Measurement uncertainty [dB]
0	± 0.207		± 0.015
-5	± 0.075		± 0.015
-10	± 0.042		± 0.012
-15	± 0.031		± 0.012
-25	± 0.030		± 0.0087
-30	± 0.035		± 0.0087
-35	± 0.040		± 0.012
-40	± 0.045		± 0.012
-45	± 0.056		± 0.015

Power level [dBm]	Test limit [dB]	Test result [dB]	Measurement uncertainty [dB]
-50	± 0.067		± 0.015
-55	± 0.078		± 0.017
-60	± 0.091		± 0.017
-65	± 0.106		± 0.019
-70	± 0.125		± 0.019
-75	± 0.151		± 0.021
-80	± 0.189		± 0.021
-85	± 0.248		± 0.023
-90	± 0.346		± 0.023
-95	± 0.509		± 0.024
-100	± 0.785		± 0.024
-105	± 1.248		± 0.026
-110	± 2.008		± 0.026

Direction: S41 (Options 413 and 414 only)

Power level [dBm]	Test limit [dB]	Test result [dB]	Measurement uncertainty [dB]
0	± 0.207		± 0.015
-5	± 0.075		± 0.015
-10	± 0.042		± 0.012
-15	± 0.031		± 0.012
-25	± 0.030		± 0.0087
-30	± 0.035		± 0.0087
-35	± 0.040		± 0.012
-40	± 0.045		± 0.012
-45	± 0.056		± 0.015
-50	± 0.067		± 0.015
-55	± 0.078		± 0.017
-60	± 0.091		± 0.017
-65	± 0.106		± 0.019

Performance Tests
E5071A Performance Test Record

Power level [dBm]	Test limit [dB]	Test result [dB]	Measurement uncertainty [dB]
-70	± 0.125		± 0.019
-75	± 0.151		± 0.021
-80	± 0.189		± 0.021
-85	± 0.248		± 0.023
-90	± 0.346		± 0.023
-95	± 0.509		± 0.024
-100	± 0.785		± 0.024
-105	± 1.248		± 0.026
-110	± 2.008		± 0.026

Uncorrected System Performance Test

Port 1

System performance	Frequency range [Hz]	Test limit [dB]	Test result [dB]
Directivity	3 M - 3 G	< -10	
Directivity	3 G - 6 G	< -6	
Directivity	6 G - 8.5 G	< -4	
Source match	3 M - 3 G	< -15	
Source match	3 G - 6 G	< -10	
Source match	6 G - 8.5 G	< -10	
Load match	3 M - 3 G	< -17	
Load match	3 G - 6 G	< -12	
Load match	6 G - 8.5 G	< -12	

Port 2

System performance	Frequency range [Hz]	Test limit [dB]	Test result [dB]
Directivity	3 M - 3 G	< -10	
Directivity	3 G - 6 G	< -6	
Directivity	6 G - 8.5 G	< -4	
Source match	3 M - 3 G	< -15	

System performance	Frequency range [Hz]	Test limit [dB]	Test result [dB]
Source match	3 G - 6 G	< -10	
Source match	6 G - 8.5 G	< -10	
Load match	3 M - 3 G	< -17	
Load match	3 G - 6 G	< -12	
Load match	6 G - 8.5 G	< -12	

Port 3 (Options 313, 314, 413 and 414 only)

System performance	Frequency range [Hz]	Test limit [dB]	Test result [dB]
Directivity	3 M - 3 G	< -10	
Directivity	3 G - 6 G	< -6	
Directivity	6 G - 8.5 G	< -4	
Source match	3 M - 3 G	< -15	
Source match	3 G - 6 G	< -10	
Source match	6 G - 8.5 G	< -10	
Load match	3 M - 3 G	< -17	
Load match	3 G - 6 G	< -12	
Load match	6 G - 8.5 G	< -12	

Port 4 (Options 413 and 414 only)

System performance	Frequency range [Hz]	Test limit [dB]	Test result [dB]
Directivity	3 M - 3 G	< -10	
Directivity	3 G - 6 G	< -6	
Directivity	6 G - 8.5 G	< -4	
Source match	3 M - 3 G	< -15	
Source match	3 G - 6 G	< -10	
Source match	6 G - 8.5 G	< -10	
Load match	3 M - 3 G	< -17	
Load match	3 G - 6 G	< -12	
Load match	6 G - 8.5 G	< -12	

Performance Tests
E5071A Performance Test Record

3 Adjustment

This chapter provides the adjustment information for the E5070A/E5071A ENA Series Network Analyzer to ensure that the it is within its specifications. The adjustment must be performed Agilent's qualified service personnel. If you need the adjustment for your E5070A/E5071A, it should be sent to the nearest Agilent Technologies service office.

Safety Considerations

This manual contains NOTES, CAUTIONs, and WARNINGs that must be followed to ensure the safety of the operator and to keep the instrument in a safe and serviceable condition. The adjustment must be performed by Agilent's qualified service personnel.

WARNING

Any interruption of the protective ground conductor (inside or outside the equipment) or disconnection of the protective ground terminal can make the instrument dangerous. Intentional interruption of the protective ground system for any reason is prohibited.

Warm-up for Adjustment

Warm-up the E5070A/E5071A for at least 30 minute before performing any of the following Adjustment procedures to ensure proper results and correct instrument operation.

Required Equipment

Table 1-1 on page 20 lists the equipment required to perform the Adjustment procedures described in this chapter. Use only calibrated test equipment when adjusting the E5070A/E5071A.

Required Adjustment after Replacing Assembly

After replacing the following assembly, the adjustment items described in Table 3-1 must be required. The adjustment must be performed Agilent's qualified service personnel. If you need the adjustment for your E5070A/E5071A, it should be sent to the nearest Agilent Technologies service office.

Table 3-1 Required Adjustment Item after Replacing Assembly

Replaced Assembly	Adjustment Item					
	Writing ID	Frequency Reference Adjustment	Oven Reference Adjustment (Opt. 1E5)	IF Range Gain/Phase Adjustment	Source Power Adjustment	Test Ports Characteristics Adjustment
Source Board		√			√	√
Receiver (RF) Board					√	√
Receiver (IF) Board				√	√	√
RF Switch					√	√
Crystal Oven (Opt. 1E5)			√			
Attenuator (Opt.214, 314 and 414)					√	√
Hard Disk Drive						
Analog Interface Board	√					

Writing ID

This item writes the serial number and the option structure into the E5070A/E5071A.

Required equipment for the writing ID

None

Frequency Reference Adjustment

The purpose of this procedure is to adjust the 10 MHz frequency reference on the source board.

Adjustment

Required Adjustment after Replacing Assembly

Required equipment for frequency reference adjustment

Description	Recommended Model
Frequency Counter	Agilent 53181A Opt. 010
Frequency Standard	Agilent 5071A
BNC(m)-BNC(m) Cable, 61 cm	Agilent p/n 8120-1839

Oven Reference Adjustment

The purpose of this procedure is to adjust the frequency of the crystal oven on the crystal oven assembly.

Required equipment for the oven reference adjustment

Description	Recommended Model
Frequency Counter	Agilent 53181A Opt. 010
Frequency Standard	Agilent 5071A
BNC(m)-BNC(m) Cable, 61 cm	Agilent p/n 8120-1839

IF Range Gain/Phase Adjustment

The purpose of this procedure is to adjust difference of the gain and phase between neighbor IF ranges.

Required equipment for the F rang gain/phase adjustment

Description	Recommended Model
6 dB Attenuator	Agilent 8491A w/Opt. 006 and H60
N(m)-N(m) Cable, 61 cm	Agilent N6314A (p/n 8120-8862)

Source Power Adjustment

The purpose of this procedure is to adjust the output level from the source board.

Required equipment for the source power adjustment

Description	Recommended Model
Power Meter	Agilent E4419A/B
Power Sensor	Agilent E4412A
Power Sensor	Agilent 8482A

Test Ports Characteristics Adjustment

The purpose of this procedure is to adjust source match, directivity and tracking.

Required equipment for the test port characteristics adjustment

Description	Recommended Model
Calibration Kit	Agilent 85052F
N(m)-N(m) Cable	Agilent N6314A (p/n 8120-8862)

Adjustment
Required Adjustment after Replacing Assembly

4 Troubleshooting

This chapter provides procedure to isolate a faulty assembly in the E5070A/E5071A Network Analyzer

Introduction

WARNING These servicing instructions are for use by qualified personnel only. To avoid possible electrical shock, do not perform any servicing unless you are qualified to do so.

WARNING The opening of covers or removal of parts is likely to expose dangerous voltages. Disconnect the instrument from its power supply beforehand.

CAUTION Many of the assemblies in the instrument are very susceptible to damage from ESD (electrostatic discharge). Perform the following procedures only at a static-safe workstation and wear a grounding strap.

CAUTION DO NOT operate without following instructions. Programs or files in the instrument may be broken.

How to exit from the E5070A/E5071A Measurement View

You need to exit from the E5070A/E5071A Measurement View to perform some troubleshooting. The following is the procedure to exit from the E5070A/E5071A Measurement View.

- Step 1.** Connect the mouse and external keyboard to the connectors on the E5070A/E5071A rear panel.
- Step 2.** Turn the instrument on.
- Step 3.** Press **System** key.
- Step 4.** Click **Service Menu** and **Restart Menu**. Password dialog box opens as shown in Figure 4-1.

Figure 4-1

Password dialog box



- Step 5.** Enter the password **e507xa** in the Password box and then click "OK" button.
- Step 6.** Click **Restart as Service** in Restart Menu. "E5070" dialog box opens and prompts you to make sure that you are going to restart the instrument (in windows desktop mode).
- Step 7.** Click "OK" button and wait for about 40 seconds to exit the Measurement View. Then windows desktop screen appears with 4 icons (My Computer, Recycle Bin, Network Neighborhood, and Restart as Instr.)

NOTE

If you wish to return to the Measurement View, double-click "Restart as Instr" icon. Then click "OK" button in "Restart as Instr" dialog box .

NOTE

If you need to shut down the E5070A/E5071A and again turn on, perform in accordance with the following procedure.

- a. To get "Start" menu bar displayed, move the pointer to the bottom of the screen with mouse.
- b. Click "Start" and "Shut Down..." in the pull up menu. "Shut Down Windows" dialog box opens.
- c. Click "Shut down" button in the dialog box.
- d. Click "OK" button in the dialog box.

To Troubleshoot the Instrument

This section describes basic procedural flow of troubleshooting when servicing the E5070A/E5071A. The primary procedural tool in this section is the flowchart. The flowchart contains entire troubleshooting path from a failure symptom to the isolation of faulty assembly, and will direct you to the completion of repair in an ordinary manner through the possible failure symptoms. Reference letters (Yes/No) on the flowcharts point to procedural steps that briefly explain the troubleshooting method to be performed next.

Primary Trouble Isolation

The primary trouble isolation procedure can be performed without disassembling the E5070A/E5071A. Figure 4-2 shows the trouble isolation flow chart.

Step 1. Turn the instrument power on

About a few minutes after the E5070A/E5071A is turned on, the measurement view is displayed on the screen. The display on the screen should be similar to Figure 4-13, “Measurement view,” on page 155.

Step 2. Check the display

- If no display appears on the LCD after the E5070A/E5071A is turned on, go to “No Display troubleshooting” on page 144.
- If the E5070A/E5071A stops in booting process despite something being displayed on the LCD, go to “Booting Process Troubleshooting” on page 147.
- The power-on self test is performed once automatically after the E5070A/E5071A measurement view is displayed. If the power-on self test fails, go to “Troubleshooting Using Internal Test” on page 156.

Step 3. Check the basic function

If the front-panel/keyboard/mouse controls, LCD display, data storage, remote interface or another function (except for measurement part) does not work correctly, go to “Function Specific Troubleshooting” on page 165.

Step 4. Check the measurement function

If the instrument fails performance tests, go to “Performance test failure troubleshooting” on page 214.

If the measurement function does not work correctly, perform the internal test and external test provided in the E5070A/E5071A's service function. When the internal test fails, go to “Internal Test Failure Troubleshooting” on page 160. When the external test fails, go to “External Test Failure Troubleshooting” on page 208.

NOTE

The internal test includes some unique measurement function tests in addition to the tests that are common to the power-on self test. Thus, it is necessary to perform the internal test even if the power-on self test passed.

Figure 4-2 Primary trouble isolation flowchart

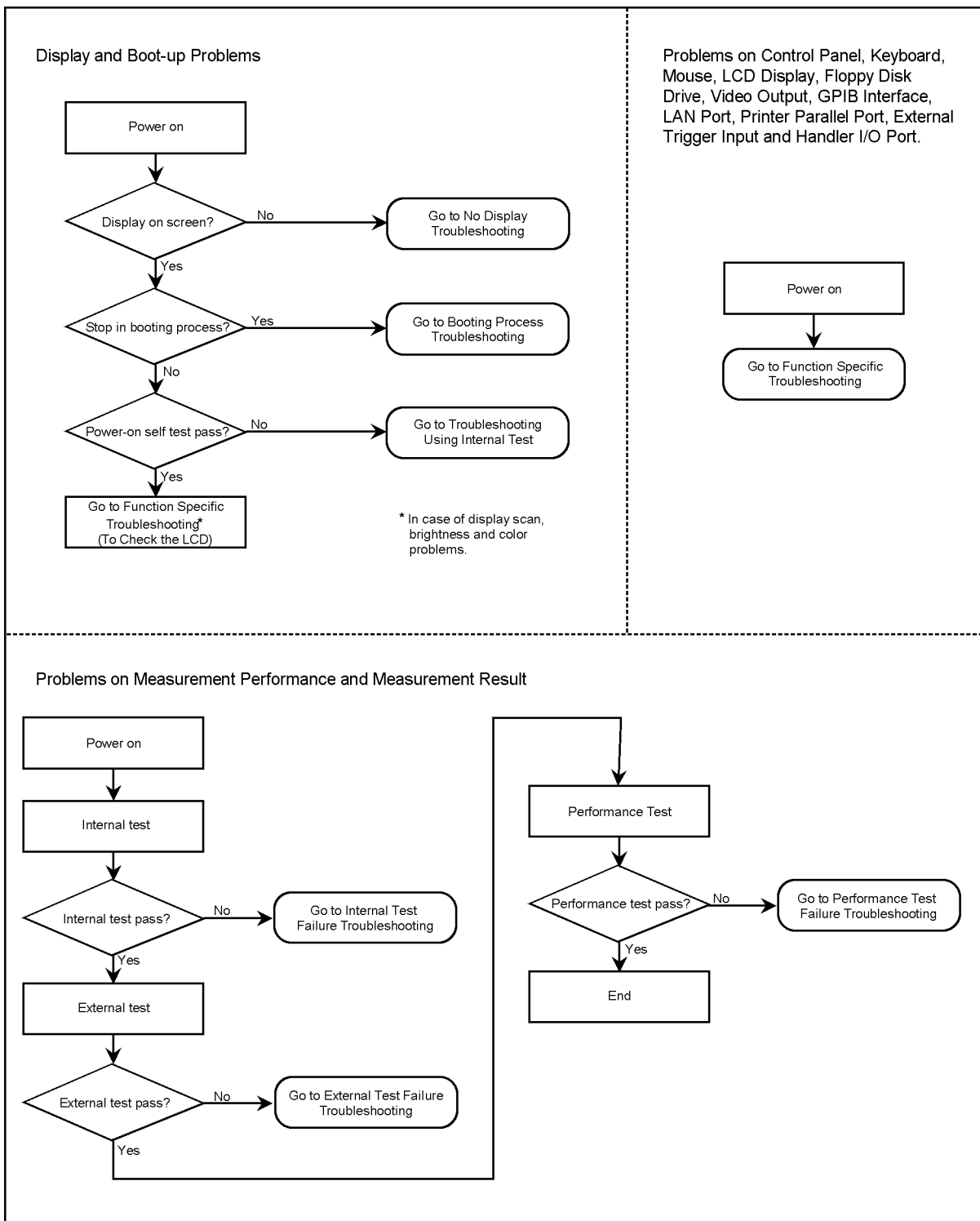

e5070ase288

No Display troubleshooting

If the E5070A/E5071A displays nothing despite it is powered from proper ac power line, isolate the failure in accordance with the procedure shown in Figure 4-3.

Connect the keyboard to the E5070A/E5071A rear panel connector, turn the power on and start trouble isolation. The methods of trouble isolation are described in the procedural step 1 to 5.

Figure 4-3

No display trouble isolation procedure

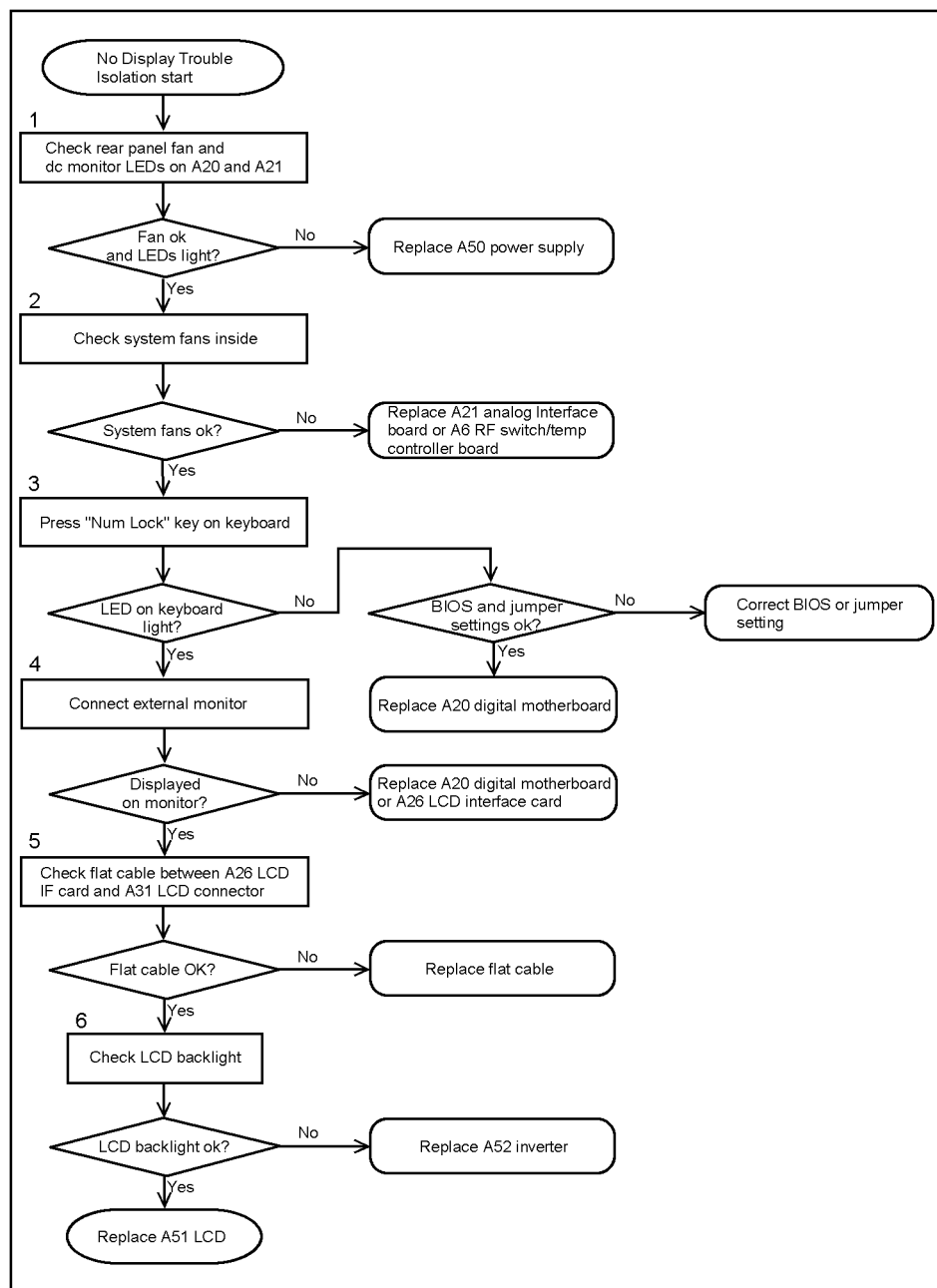

e5070ase156

Step 1. Check fan operation and DC monitor LED

If the rear panel fan (blower) doesn't run, a failure in A50 ATX power supply is assumed. Remove the E5070A/E5071A outer cover and check if the following LEDs light:

- +3.3V and +5V dc monitor LEDs on A21 analog interface board
- 2-digits seven-segment LEDs on A20 digital motherboard that normally display "00"

NOTE

To check all the outputs of the A50, measure the dc voltages at the output lead connectors with a DMM. The dc output voltages and lead color information is provided in the module cover label of the A50.

Step 2. Check system fans inside.

If the system fans on the chassis inside the E5070A/E5071A don't run, problem seems in the A21 analog interface board or the flat cable between the A21 and the A22 front panel keyboard. In this case, remove the E5070A/E5071A outer cover and make sure whether the fans run or not.

If a beep and a power shutdown occur immediately after power on, there is a possibility that either of the fans doesn't run. There are three system fans, which are independently controlled by A6 RF switch/temperature controller board. These fans initially run fast after the power is turned on, and usually stop after a while. One or some of them restart running when the instrument warms up. The power shutdown occurs the moment the system fan stops by any anomaly. In this case, check the A6 board and the fan that doesn't run.

If the power shutdown occurs without a beep, the problem seems in the A21 or the A20 board.

NOTE

Before replacing the board, check if jumper settings on the A20 are correct as described in "Configure the Motherboard" on page 216.

Step 3. Check LED of "Num Lock" key

Press "Num Lock" key on the keyboard. If the LED in the key doesn't light as shown in Figure 4-4, a problem seems in the A20 digital motherboard.

Figure 4-4

LED of the Num Lock key

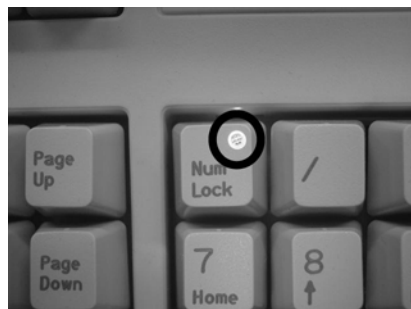

If 2-digits seven-segment LED display (POST DISPLAY) on the A20 board indicates a number other than "00", a failure in the A20 board is suspected.

Make sure the followings before replacing the A20 board.

- Whether all the connections to the A20 are normal or not. Check if there is any disconnection or connection working loose.
- Whether the jumper settings on the A20 are correct or not as described in “Configure the Motherboard” on page 216.
- Whether BIOS options are correct or not as described in “To Confirm or Set the BIOS Options” on page 218.

NOTE

The LED display cannot surely indicate whether the A20 board is normal or faulty. ("00" may be displayed despite the A20 is faulty.)

Step 4. Checking with the external monitor

Connect an external VGA monitor to the VIDEO output on the E5070A/E5071A rear panel.

- If something is displayed on the external monitor, the problem is present around the LCD. Also check the A21 and A22 because the ON/OFF setting of the LCD backlight is controlled by the A21 through the A22 front interface board.
- If nothing is displayed even on the external monitor, the problem seems in the A20 digital motherboard or A26 LCD interface card.

NOTE

Check if the A26 board is securely connected to the A20 board.

Step 5. Checking flat cable

Check a flat cable between the A26 and A31 LCD connector.

Step 6. Check around the backlight

Check A52 inverter board and a cable between the A52 and A26. Also check the cables between the A51 LCD and A52. If the cables are normal, check the A51 LCD.

Booting Process Troubleshooting

Figure 4-5 represents the booting process flow in the E5070A/E5071A. If the E5070A/E5071A stops in the booting process, troubleshoot using the following step-by-step procedure.

Figure 4-5

Booting process flowchart

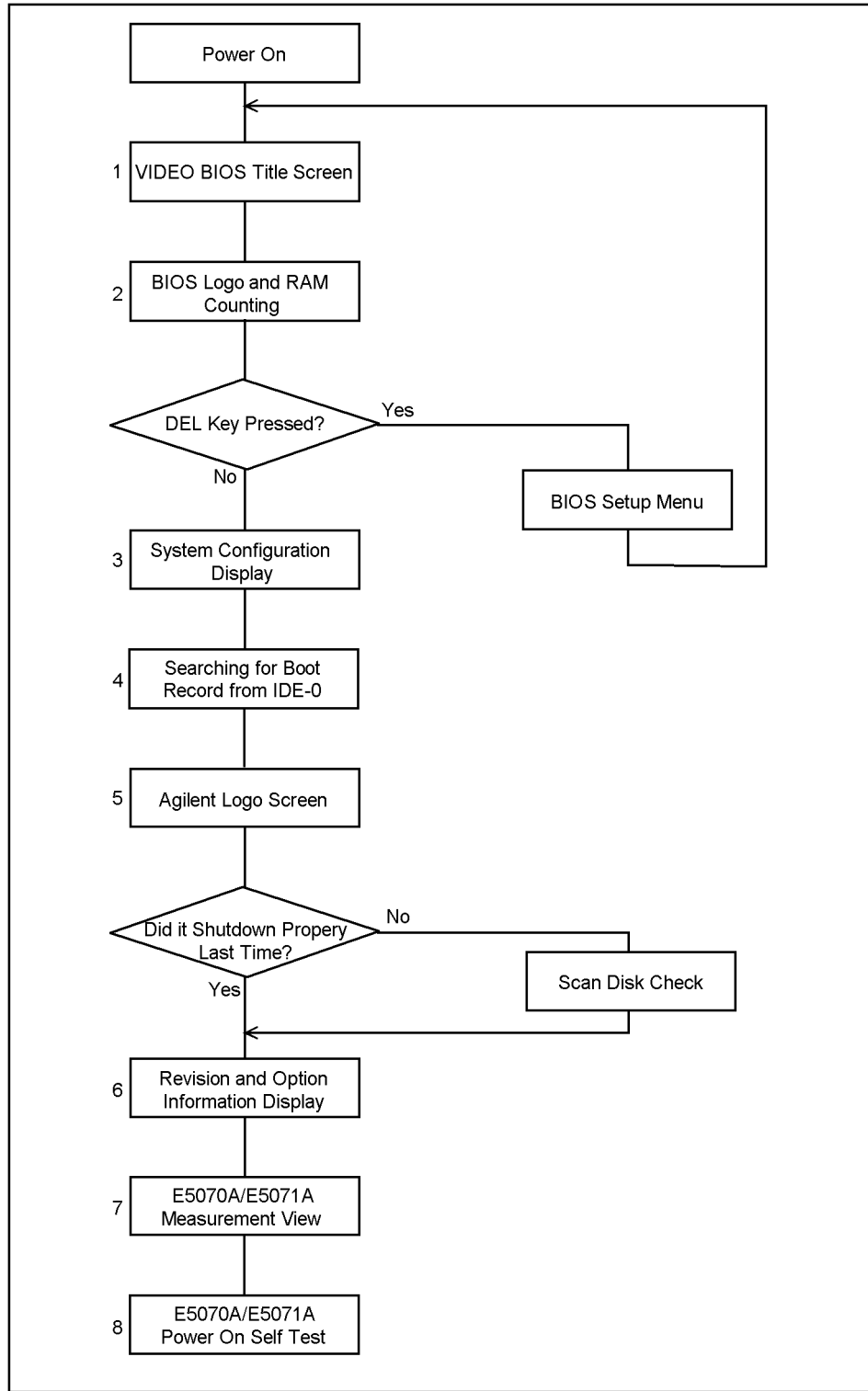

e5070ase157

Step 1. Video BIOS booting

Video BIOS title screen shown in Figure 4-6 is displayed first, when the E5070A/E5071A

is turned on. If this screen doesn't appear (nothing appears), go to “No Display troubleshooting” on page 144.

Figure 4-6 Video BIOS title screen

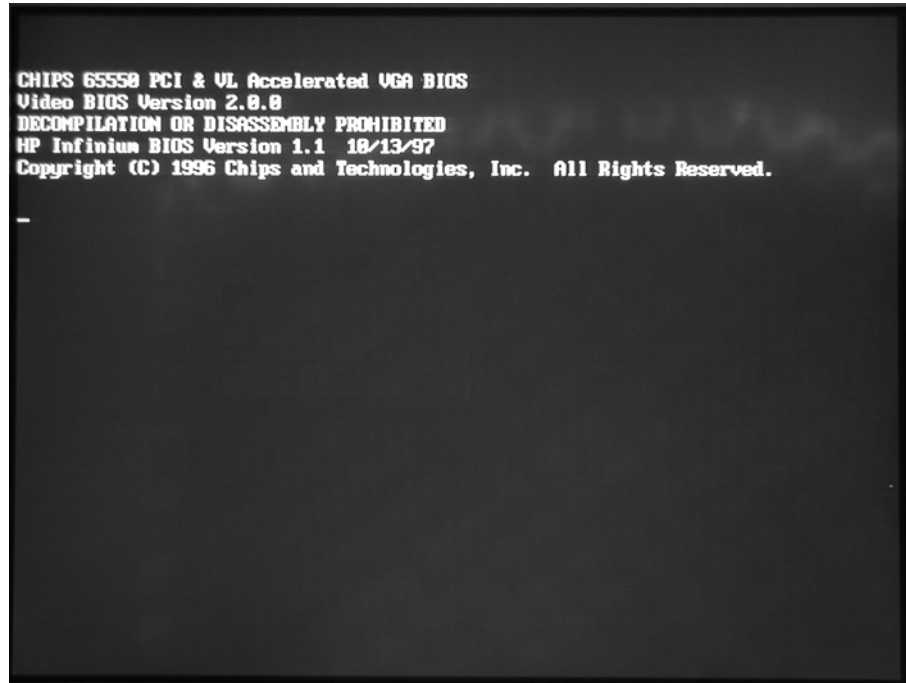

Step 2. BIOS logo and RAM counting

BIOS logo screen as shown in Figure 4-7 describes the BIOS name, model number of the digital motherboard, CPU type, RAM size on the digital motherboard and type of the mass storage.

If the message is displayed, you can assume that the A20 digital motherboard is functioning correctly.

If the message stops during RAM counting, a problem in the A20 board is suspected.

NOTE

If you want to run the BIOS setup utility, push Delete key as soon as the message of "Hit DEL if you want to run SETUP" is displayed during RAM counting. The BIOS setup utility allows you to perform the followings.

- Setting the system date and time
- Changing the first boot device (if you want to boot from a floppy disk, it is necessary to change it.)
- Confirming the BIOS options

For details of the BIOS options specified for the E5070A/E5071A, refer to “To Confirm or Set the BIOS Options” on page 218.

Figure 4-7

BIOS logo and RAM counting screen

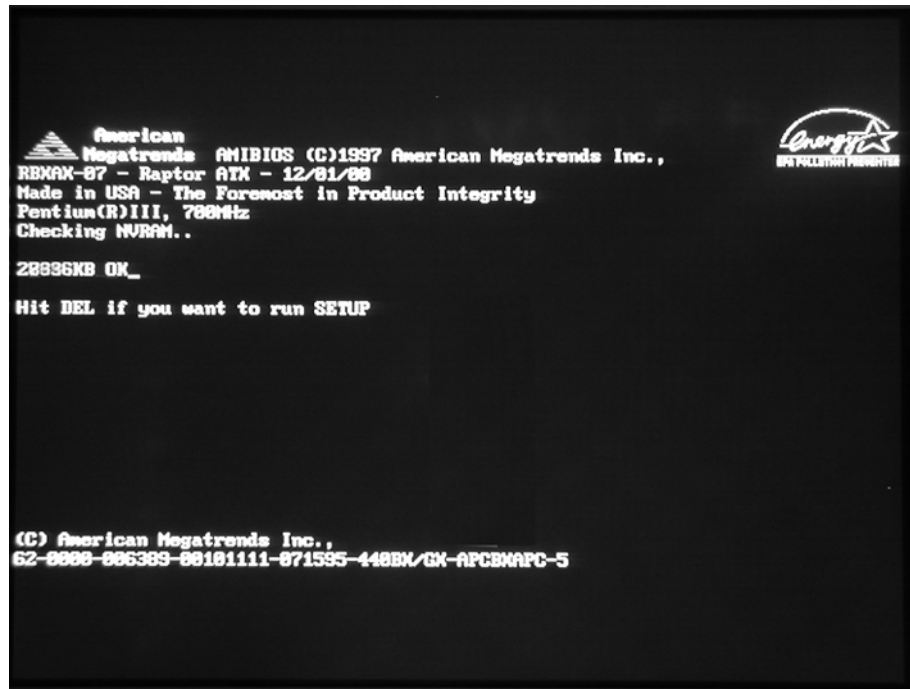

Step 3. System configuration

The BIOS checks the E5070A/E5071A configuration and displays the results as shown in Figure 4-8. Two PCI boards, A21 and A26 can be confirmed as follows:

- PCI Slot 3: "VGA" is A26 LCD interface card.
- PCI Slot 4: "Bridge Device, IRQ5" is A21 analog interface board.

If the BIOS couldn't detect the above boards due to a hardware problem or incomplete PCI slot connection, nothing is displayed there. Additionally, the BIOS cannot check the operation of the above boards. In this case, check first whether a PCI slot connection has a problem (poor contact) or not.

A24 GPIB card cannot be confirmed because it is on the ISA slot.

Figure 4-8 System configuration page

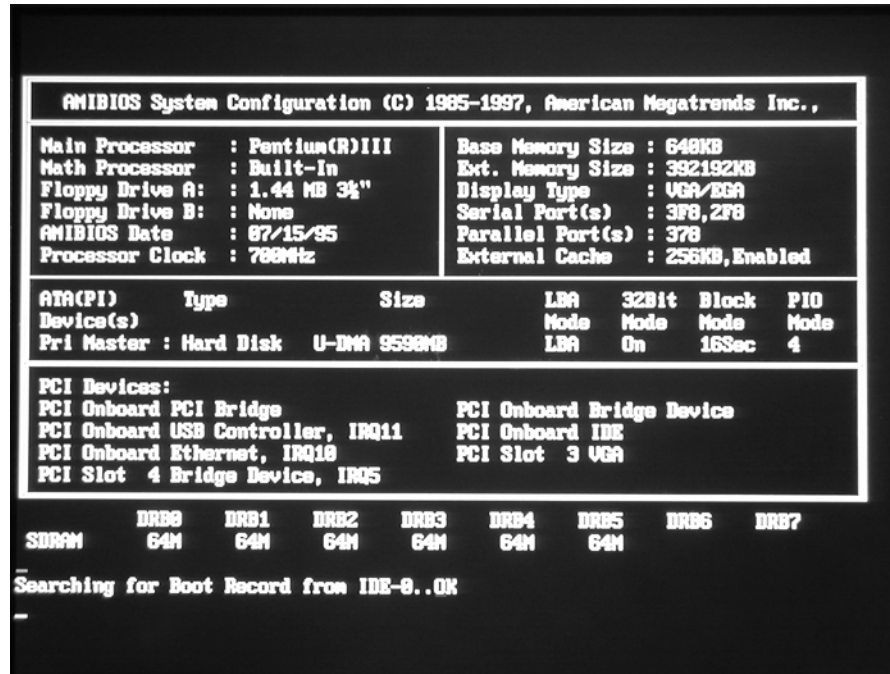

Step 4. Searching for boot record

A message of " Searching for Boot Record from IDE-0..OK" shown in Figure 4-8 is displayed after the system configuration check is performed. At this moment, the E5070A/E5071A starts booting from A27 mass storage (IDE-0) without problem. However, if the E5070A/E5071A cannot boot from the A27, a message of "Boot Failure" is displayed as shown in Figure 4-9. In this case, the E5070A/E5071A may have a problem around the A27.

Figure 4-9

Message of Boot Failure

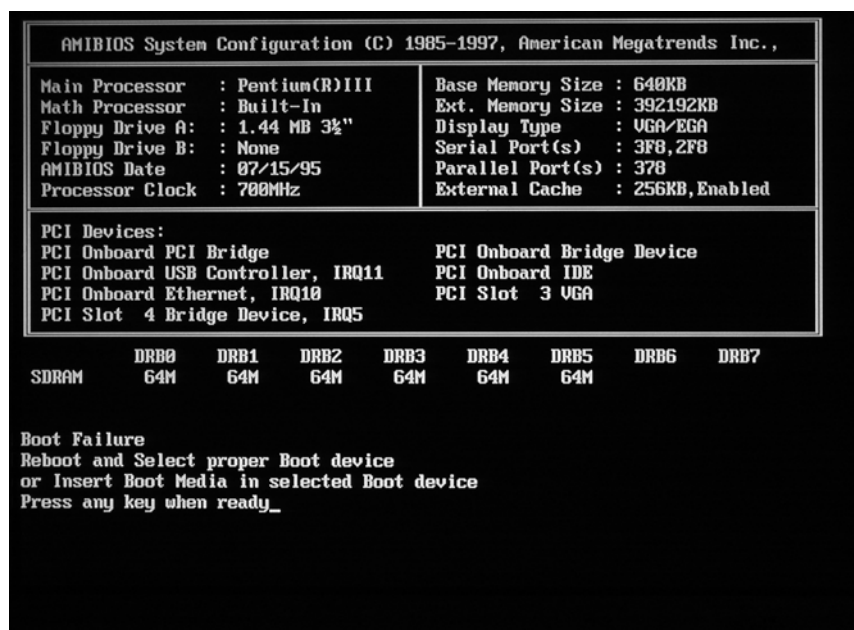

Check whether the A27 has a problem or is not using BIOS setup utility as shown in Figure 4-10. For details of how to run the BIOS setup utility, refer to “Run the BIOS setup utility” on page 219.

Move the cursor to "Auto-Detect Hard Disks" using and keys on the keyboard and press Enter key at the BIOS setup utility main menu. When the mass storage is detected, the disk size, cyln and so on are displayed as shown in Figure 4-10.

Figure 4-10

Auto-Detect Hard Disk page

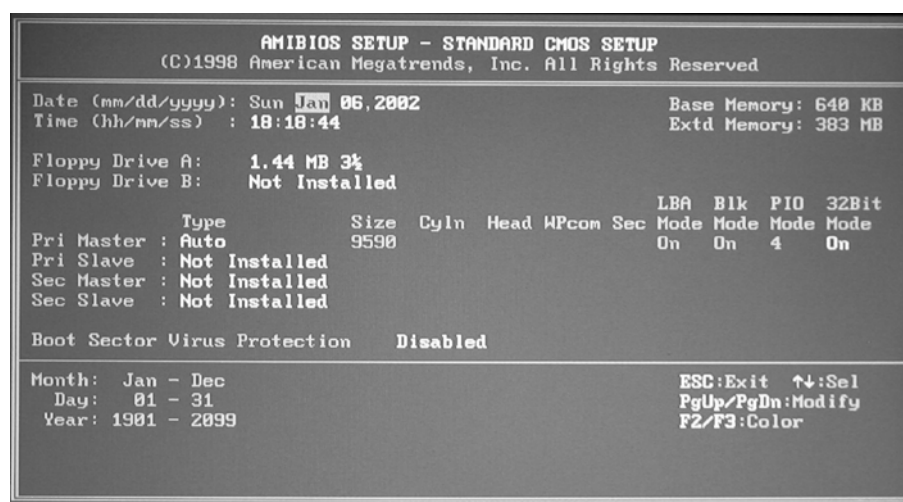

If the mass storage is not detected, "Not installed" is displayed in the Pri Master status report. The A27 mass storage is connected to the IDE connector on the A20 digital motherboard via A30 3.5"-2.5" adapter and a flat cable. Check the flat cable first. If it has no problem, replace the A27 mass storage.

Step 5. Agilent logo screen

Agilent Technologies logo screen is displayed as shown in Figure 4-11. Since the logo file is in the A27 mass storage, if the logo is displayed, it is assumed that the A27 works. Subsequently, a message of "Push [R] key to enter recovery mode [R, N]?" is displayed for a moment and the Agilent logo screen recovers. While the logo screen is displayed, Windows operating system is starting up.

Figure 4-11 Agilent logo screen

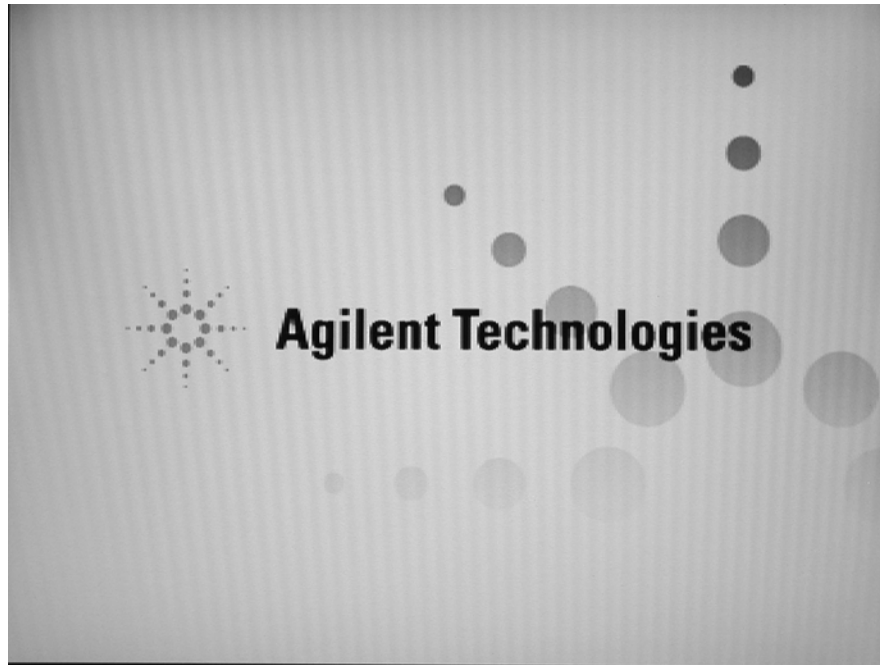

NOTE

If the E5070A/E5071A was turned off without shutdown process, Microsoft Scandisk runs after the message of "Push [R] key to enter recovery mode [R, N]?" is displayed. If a serious problem is found in the scandisk, reinstall the operating system. For details of the operating system installation, refer to Appendix B, "System Recovery," on page 343. If the operating system still doesn't boot up properly after reinstallation, replace the A27.

If you encounter the following problems, try to reinstall the operating system before replacing the A27.

- "xxx file is missing" is displayed on DOS screen.
- The Agilent logo screen is not displayed after "Searching for Boot Record from IDE-0..OK" is displayed.
- Windows always boots up with Safe Mode.

NOTE

The operating system automatically checks the device drivers, which are necessary to use the E5070A/E5071A functions and are installed in the system before the E5070A/E5071A is shipped from Agilent factory. If the operating system doesn't detect them, a message box is displayed. In this case, install the device driver.

Step 6. Revision and option information

The firmware revision and hardware option information along with copyright declaration is displayed as shown in Figure 4-12. The E5070A/E5071A firmware quickly starts up just before this display appears. While the revision and option information is displayed, the applications of various devices in the system are initialized.

Figure 4-12 Firmware revision and option information

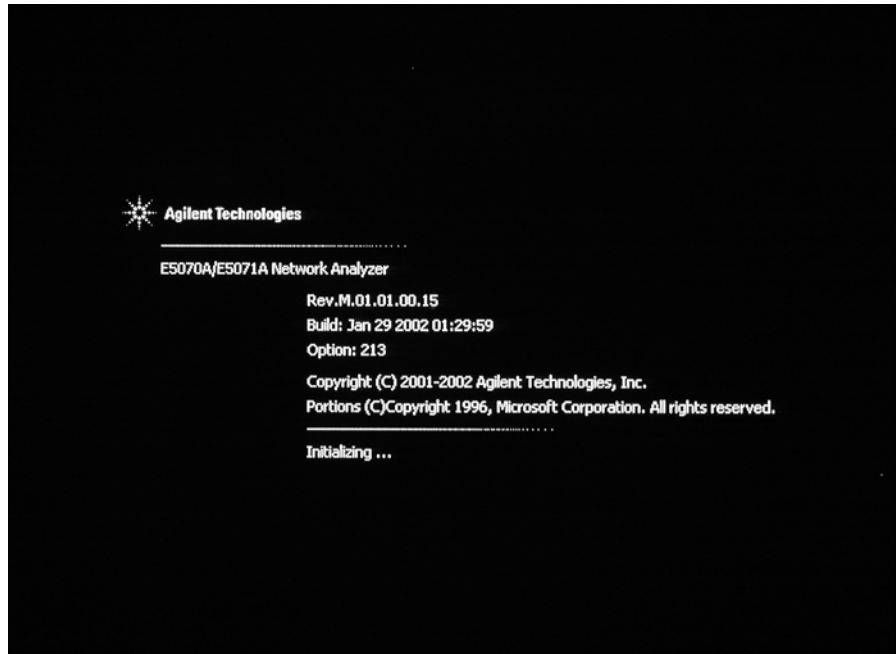

If the display whited out, entirely blued or appeared with a dialog box, a mass storage problem is suspected. Try to perform the mass storage recovery procedure.

NOTE

If a message of "Will Shut Down in Five Seconds" is displayed in place of "Initializing.." and the shutdown occurs, the A21 board fails in starting up. The following message may be displayed before the shutdown occurs:

"Fatal Error: Failed to Initialize DSP Driver":

or "Fatal Error: Failed to Initialize DSP":

This message indicates that the A21 board doesn't work or is not properly connected to the A20. When the firmware is revision 1.0 or 1.1, the problem may possibly be in the A1 source board.

"Fatal Error: Failed to Update DSP Code":

If this happened, the A21 board failed in writing DSP program into flash ROM when the firmware was installed first or updated to the newest version. A problem in the A21 or A20 is suspected.

Step 7. Measurement view

The measurement view as shown in Figure 4-13 is displayed after the system initialization is completed without problem.

Figure 4-13

Measurement view

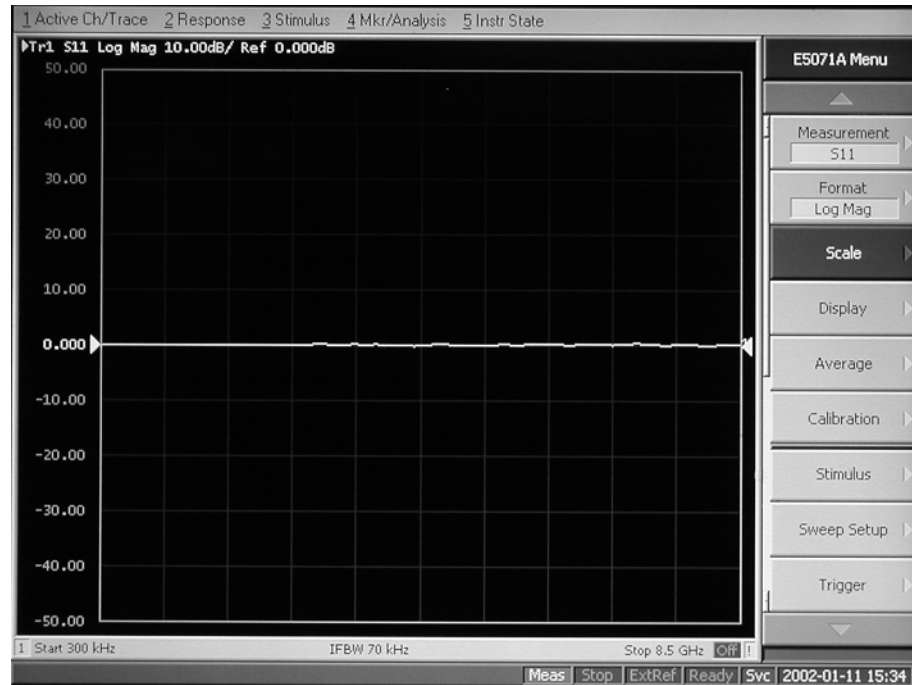

Step 8. Power-on self test

The power-on self test is executed once automatically before the measurement starts. While the power-on self test is in progress, "Power on test" is displayed at the left in the instrument status bar. If the power-on test fails, an error message is displayed there. For more details, refer to "Troubleshooting Using Internal Test" on page 156.

Troubleshooting Using Internal Test

The Agilent E5070A/E5071A has an internal test function to diagnose the analog measurement section and internal dc power supply voltages. The internal test makes it possible to isolate a faulty board assembly without need of external test equipment. The following paragraphs describe the procedure to perform the internal test.

NOTE There are two types of the internal test dialog box (test menu). This section describes the procedure for each internal test dialog box.

- Procedure where the internal test revision A.01.02 (or earlier) has been installed.
- Procedure where the internal test revision A.03.00 (or later) has been installed.

NOTE There are cases where the internal test is ineffective (insufficient) for trouble isolation because the test objects are limited to the circuit blocks and functions that can be tested with nothing connected to the test ports. In such cases, refer to external test to perform the diagnosis for the range uncovered with the internal test.

Power On Self Test

Power-on self-test always takes place once after the E5070A/E5071A is turned on. When a failure is detected, a message of the "Power on self test failed" is displayed. The content of the power-on self-test is the same as a portion of the internal test program and includes the dc power supply voltage, source PLL synthesizer and level controller (ALC) tests. When the self-test failed, perform the internal test to break down into the individual tests and narrow down failure possibilities.

NOTE The following procedure can be used to restart the power-on self test as required.

- a. Press **System** key.
 - b. Click **Service Menu** and, then, **Test Menu** in the softkeys.
 - c. Click **Power On Test** to restart the test. Wait until the power-on test ends.
 - d. The test result (OK or Failed) is displayed in the **Power On Test** key.
-

PLL unlock

When a PLL of the frequency synthesizers is unlocked, not the "Power on self test failed" but "Phase lock loop unlocked" message is displayed. If it occurs, A1 Source board may be faulty. (There is also a low possibility that A17 ADC part of A2 Receiver board is faulty).

External reference signal phase unlock (Opt. 1E5)

If the "ExtRef" in the instrument status bar is displayed in gray, not turning blue, in using the high stability time base (Opt. 1E5), A5 Crystal Oven board or the interconnection cable between rear panel Ref Oven and Ref In connectors may be faulty. Also check whether the "Ready" in the instrument status bar is displayed in blue (the warm-up in the instrument is completed). If it is in gray, wait until the "Ready" turns blue.

To Execute the Internal Test

To isolate faulty board assembly in analog section, execute the internal test in accordance with the following procedure. The test procedure needs to be performed using a mouse in addition to the front panel keys.

-
- NOTE** To perform the internal test properly, the following conditions must be met:
1. Environmental temperature: 23°C ± 5°C
 2. Warm-up status indicator in the instrument status bar exhibits "Ready" in blue.
-
- NOTE** Do not operate front panel keys, keyboard and mouse during the internal test. Changing the instrument settings while the internal test is in progress will cause incorrect test results.
-

- Step 1.** Connect a mouse to the rear panel connector
- Step 2.** Press **Macro Setup** key.
- Step 3.** Press **↓** - **↓** - **Enter** keys (or click **Load Project**) to select **Load Project** function. "Open" dialog box will be displayed as shown in Figure 4-14.

Figure 4-14 Open dialog box

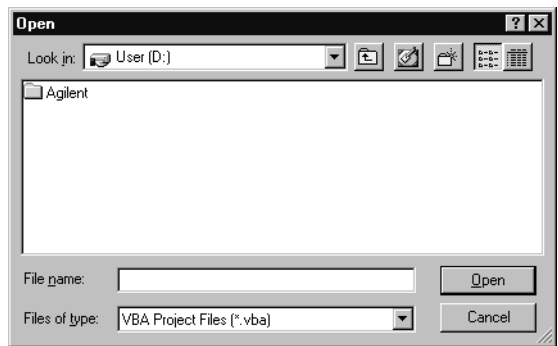

- Step 4.** Select "User [D]" (preset state) from menu in the "Lock in:" box.
- Step 5.** Double-click "Agilent" folder to open it and to access its menu.
- Step 6.** Double-click "Service" folder to open it.
- Step 7.** Click "Internal Test. VBA" program file to select it from program menu.
- Step 8.** Click "Open" button to download the internal test program.
- Step 9.** Press **↓** - **↓** - **↓** - **Enter** (or click **Select Macro**) to select **Select Macro** function.
- Step 10.** Press **Enter** (or click **Module1 main**) to open the **Module1 main** program file. "Internal Test" dialog box will appear as shown in Figure 4-15. The dialog box shows the menu of test groups to choose from.

Figure 4-15 Internal Test dialog box (rev. A01.02 or earlier)



Figure 4-16 Internal Test dialog box (rev. A03.00 or later)

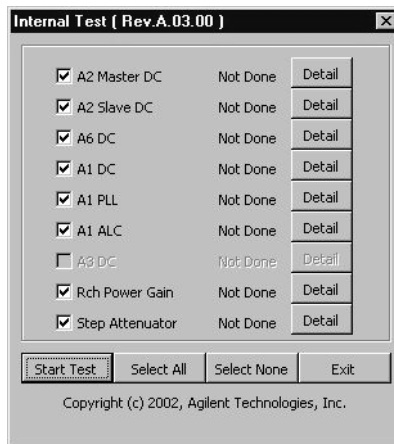

e5070ase298

Step 11. All the test groups are preset to take effect. If it is necessary to perform a specific test group or some test groups only, check in (click) the check boxes for the desired test group(s) and clear the other check boxes.

NOTE

Clicking "Select None" button clears all the check boxes. Clicking "Detail" button displays the names of individual tests included in each test group. Click "Exit" to return to the Internal Test dialog box.

Step 12. Click "Test" or "Start Test" button to run the internal test program. The dialog box displays "Now testing ..." while the internal test is in progress.

Step 13. When the internal test is completed, the dialog box displays Pass or Fail for each test group as an example shown in Figure 4-17.

Figure 4-17

Internal test result display example (rev. A.01.02 or earlier)

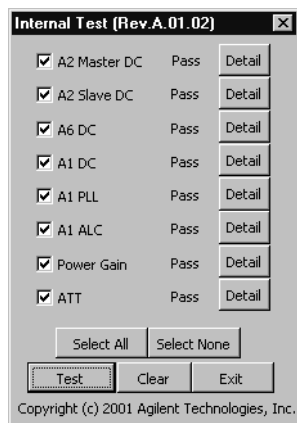
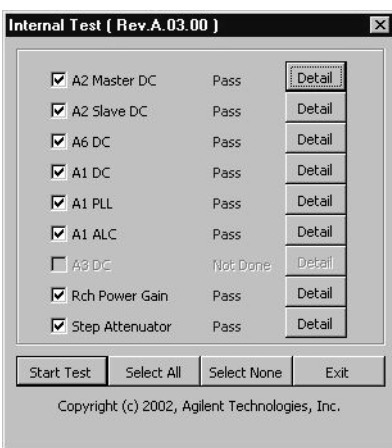

Figure 4-18

Internal test result display example (rev. A.03.00 or later)



e5070ase299

If any of the test groups failed, click "Detail" button of that test group to look into the breakdown of the test results. Figure 4-19 shows a breakdown test result example.

Figure 4-19

Breakdown test result display example (rev. A.01.02 or earlier)

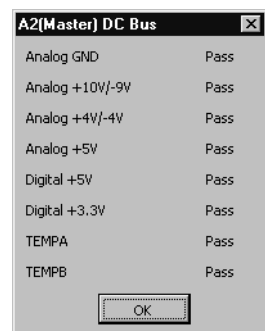
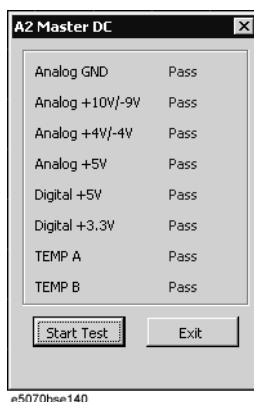

Figure 4-20 Breakdown test result display example (rev. A.03.00 or later)



Step 14. To exit the internal test, click "Exit" button.

NOTE

Clicking "Select None" button clears all the check boxes, but it does not clear the test results. To initialize the internal test rev. A.01.02 (or earlier), click "Clear" button. (Test results will change to "Not Done".)

Internal Test Failure Troubleshooting

Table 4-1 represents the contents of the internal tests and the relationships of failed tests to probable faulty board assemblies. If the instrument fails the internal test, replace the faulty board assembly as shown in Table 4-1.

Table 4-1 Internal tests failure troubleshooting information

Test No.	Test group	First failed test	Test point / objective	Probable faulty board assembly				
				A1 Source	A6 Sw/T cont	A2 Receiver		A7 Att
						A14	A17	
1	A2 Master DC	Analog GND	DC bus on A2 (master)				###	
2		Analog +10V/-9V	+10V and -9V on A2				###	
3		Analog +4V/-4V	+4V and -4V on A2				###	
4		Analog +5V	+5V for analog on A2				###	
5		Digital +5V	+5V for digital on A2				###	
6		Digital +3.3V	+3.3V on A2				###	
7		TEMPA	Thermometer A			##	###	
8		TEMPB	Thermometer B			##	###	

Table 4-1 Internal tests failure troubleshooting information

Test No.	Test group	First failed test	Test point / objective	Probable faulty board assembly				
				A1 Source	A6 Sw/T cont	A2 Receiver		A7 Att
						A14	A17	
9	A2 Slave DC(Opt. 313/314/413/414 only)	Analog GND	DC bus on A2 (slave)				###	
10		Analog +10V/-9V	+10V and -9V on A2				###	
11		Analog +4V/-4V	+4V and -4V on A2				###	
12		Analog +5V	+5V for analog on A2				###	
13		Digital +5V	+5V for digital on A2				###	
14		Digital +3.3V	+3.3V on A2				###	
15		TEMPA	Thermometer A on A2			##	###	
16		TEMPB	Thermometer B on A2			##	###	
17	A6 DC	Analog GND	DC bus on A6		###		#	
18		Analog +11V	+11V on A6		###		#	
19		AP5V	+5V on A6		###		#	
20		FAN1	Blower control 1 on A6		###		#	
21		FAN2	Blower control 2 on A6		###		#	
22		FAN3	Blower control 3 on A6		###		#	
23	A1 DC	RVT	DC bus on A1	###			#	
24		VTEMP	Thermometer on A1	###			#	
25	A1 PLL	FVT(2.80000GHz)	Fixed synthesizer on A1	###			#	
26		FVT(2.84375GHz)	Fixed synthesizer on A1	###			#	
27		SVT(2.11GHz)	Source swept synthe on A1	###			#	
28		LVT(2.11GHz)	Local swept synthe on A1	###			#	
29		SVT(4.25GHz)	Source swept synthe on A1	###			#	
30		LVT(4.25GHz)	Local swept synthe on A1	###			#	

4. Troubleshooting

Table 4-1 Internal tests failure troubleshooting information

Test No.	Test group	First failed test	Test point / objective	Probable faulty board assembly				
				A1 Source	A6 Sw/T cont	A2 Receiver		A7 Att
						A14	A17	
31	A1 ALC	SAV(DAC100)	Source level control on A1	###			#	
32		SAV(DAC2000)	Source level control on A1	###			#	
33		SOP(f=300k)	Source ALC on A1	###			#	
34		LOP(f=300k)	Local ALC on A1	###			#	
35		SOP(f=1.3G)	Source ALC on A1	###			#	
36		LOP(f=1.3G)	Local ALC on A1	###			#	
37		SOP(f=1.31G)	Source ALC on A1	###			#	
38		LOP(f=1.31G)	Local ALC on A1	###			#	
39		SOP(f=2.1G)	Source ALC on A1	###			#	
40		LOP(f=2.1G)	Local ALC on A1	###			#	
41		SOP(f=2.11G)	Source ALC on A1	###			#	
42		LOP(f=2.11G)	Local ALC on A1	###			#	
43		SOP(f=4.25G)	Source ALC on A1	###			#	
44		LOP(f=4.25G)	Local ALC on A1	###			#	

Table 4-1 Internal tests failure troubleshooting information

Test No.	Test group	First failed test	Test point / objective	Probable faulty board assembly				
				A1 Source	A6 Sw/T cont	A2 Receiver		A7 Att
						A14	A17	
45	Power Gain (A1 and A2)	S11(50MHz)	Source power and Ref channel receiver gain for Port 1	##		##	##	
46		S11(3GHz)	Source power and Ref channel receiver gain for Port 1	##		##	##	
47		S11(6GHz)	Source power and Ref channel receiver gain for Port 1 (E5071A)	##		##	##	
48		S22(50MHz)	Source power and Ref channel receiver gain for Port 2	##		##	##	
49		S22(3GHz)	Source power and Ref channel receiver gain for Port 2	##		##	##	
50		S22(6GHz)	Source power and Ref channel receiver gain for Port 2 (E5071A)	##		##	##	
51		S33(50MHz)	Source power and Ref channel receiver gain for Port 3 (Opt.313/314/413/414)	##		##	##	
52		S33(3GHz)	Source power and Ref channel receiver gain for port 3 (Opt.313/314/413/414)	##		##	##	
53		S33(6GHz)	Source power and Ref channel receiver gain for Port 3 (E5071A Opt.313/314/413/44)	##		##	##	
54		S44(50MHz)	Source power and Ref channel receiver gain for Port 4 (Opt.413/414)	##		##	##	
55		S44(3GHz)	Source power and Ref channel receiver gain for Port 4 (Opt.413/414)	##		##	##	
56		S44(6GHz)	Source power and Ref channel receiver gain for Port 4 (E5071A Opt.413/414)	##		##	##	

4. Troubleshooting

Table 4-1 Internal tests failure troubleshooting information

Test No.	Test group	First failed test	Test point / objective	Probable faulty board assembly				
				A1 Source	A6 Sw/T cont	A2 Receiver		A7 Att
						A14	A17	
57	ATT (A7)(Opt.21 4/314/414 only)	R(5dB)-R(0dB)	Source attenuator on A7	#	##			###
58		R(10dB)-R(0dB)	Source attenuator on A7	#	##			###
59		R(15dB)-R(0dB)	Source attenuator on A7	#	##			###
60		R(20dB)-R(0dB)	Source attenuator on A7	#	##			###
61		R(25dB)-R(0dB)	Source attenuator on A7	#	##			###
62		R(30dB)-R(0dB)	Source attenuator on A7	#	##			###
63		R(35dB)-R(0dB)	Source attenuator on A7	#	##			###

###: Most suspicious assembly

##: Suspicious assembly

#: Possible faulty assembly

NOTE Internal tests from item number 1 to 44 are common to the power on self test.

NOTE When the internal test for a specific receiver port fails, identify the faulty A2 receiver board as shown in Figure 4-21.

Figure 4-21 Test port configuration

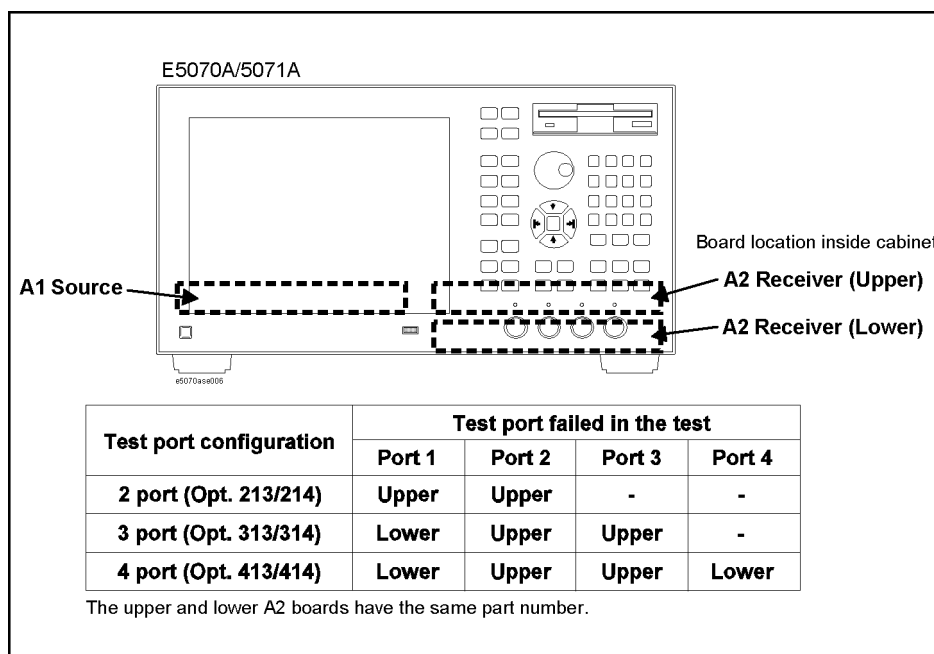

e5070ase282

Function Specific Troubleshooting

If the E5070A/E5071A exhibits a failure symptom that is related to a specific function or control such as a front panel key control, display, data storage, remote control interface, printer interface, external trigger, external keyboard or mouse, isolate the trouble using the Function Specific Troubleshooting procedures described below. The major functions of the E5070A/E5071A and the troubleshooting procedure for each function are shown in Table 4-2.

Table 4-2 Major functions and troubleshooting procedures

Function	Description	Troubleshooting
Front panel keys	All the E5070A/E5071A functions except for VBA and service functions can be set and controlled via the front panel keys.	Refer to “To Check the Front Panel” on page 167.
Touch panel	The E5070A/E5071A equipped with option 016 has a touch screen display that allows all the functions in the menu bars, setup windows and dialog boxes to be set by a touch to the screen panel.	Refer to “To Check the Touch Panel (Option 016 only)” on page 168.
LCD display	Almost all the information including the measurement value, setup state, result data processing, menu bar, softkey label and others are indicated on the 10.4-inch color LCD display.	Refer to “To Check the LCD” on page 169.
External keyboard	The external keyboard can be used for the entry of numerical and character data when it is connected to the keyboard interface connector (PS-2) on the rear panel.	Refer to “To Check the External Keyboard” on page 169.
Mouse	The mouse can be used to move the pointer on the LCD display, select a function and change a setting, when it is connected to the mouse interface connector (PS-2) on the rear panel.	Refer to “To Check the Mouse” on page 169.
Floppy disk drive	The 3.5-inch floppy disk drive on the front panel is used to save the E5070A/E5071A setup state and measurement data in a 3.5-inch, 1.4 MB floppy disk in MS-DOS compatible format.	Refer to “To Check the FDD” on page 170.
Video output	An external color monitor can be used to display the same information as the E5070A/E5071A LCD display, when it is connected to the Video output connector (24-pin D-Sub) on the rear panel.	Refer to “To Check the Video output” on page 170.
External trigger input	The external trigger input terminal (BNC) on the rear panel allows an external trigger source to be used for measurement trigger.	Refer to “To Check the External Trigger Input” on page 170.

Table 4-2 Major functions and troubleshooting procedures

Function	Description	Troubleshooting
LAN port	The LAN interface port on the rear panel allows the E5070A/E5071A to be connected to 10/100 Base-T Ethernet.	Refer to “To Check the LAN” on page 171.
Printer parallel port	A specified printer can be used to print the E5070A/E5071A measurement display, setup display and others, when it is connected to the Printer port (36-pin D-Sub) on the rear panel.	Refer to “To Check the Printer Parallel Port” on page 175.
GPIB interface	The GPIB compatibility allows the E5070A/E5071A to be operated as a talker/listener or system controller on IEEE 488 interface bus.	Refer to “To Check the GPIB” on page 176.
Handler I/O port	The Handler I/O port can be used to transfer a comparator decision output data to and perform timing synchronization with an external handler.	Perform “[13] Handler I/O Board tests” in “Troubleshooting Using External Test” on page 177 .

To Check the Device Driver

Make sure first whether the E5070A/E5071A device drivers are installed properly or not by the following procedure, if a function of specific device in the E5070A/E5071A doesn't work.

- Step 1.** Exit from the E5070A/E5071A measurement view in accordance with the procedure described in “How to exit from the E5070A/E5071A Measurement View” on page 141. Then, Windows desktop screen is displayed.
- Step 2.** Click "My Computer" and "Properties" icons to open System Properties dialog box.
- Step 3.** Click Device Manager tag. The operating system detects all the necessary device drivers and displays the device names as shown in Figure 4-22.

Figure 4-22 System Properties - Device Manager window

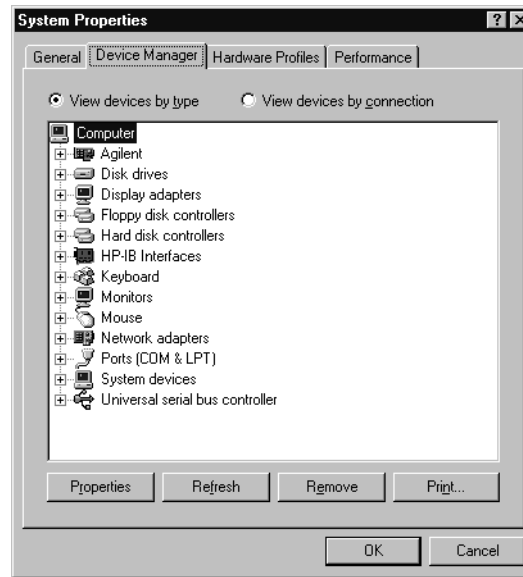

If the operating system cannot detect a necessary device driver, the device driver is marked with "X" as shown in Figure 4-23. This figure shows the example of the icon with "X" displayed when the PCI adapter (Intel(R) GD82559ER) is not detected.

Figure 4-23 Example of no device driver file in the system

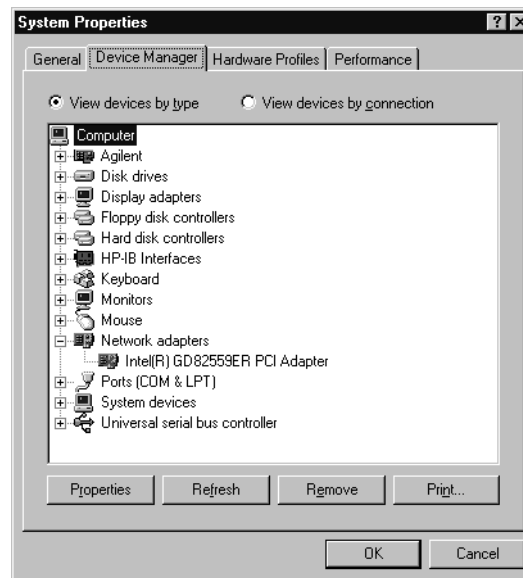

To Check the Front Panel

Procedure

Randomly press the front panel keys and rotate the knob to verify that they work normally.

Step 1. Press **[System]** key.

Troubleshooting

Function Specific Troubleshooting

Step 2. Click **Service Menu** and, then, **Test Menu** in the softkeys.

Step 3. Click **Front Panel** in the test menu. This opens "Front Panel Test" dialog box as shown in Figure 4-24.

Figure 4-24 Front Panel Test dialog box

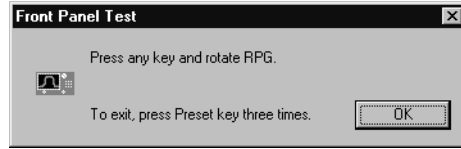

Step 4. Randomly press the front panel keys. The key code along with the name of the pressed key are displayed in the dialog box as shown in Figure 4-25. Turn the rotary knob clockwise or counterclockwise. The dialog box indicates the direction of the turned knob and a count of RPG output.

Figure 4-25 Key code and key name display example

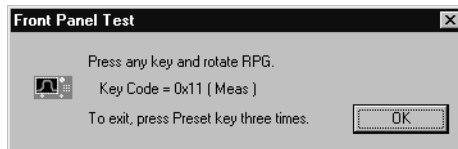

Step 5. To exit the front panel test, press **Preset** key three times.

- If multiple keys fail to work, a problem in A22 front interface board or A21 analog interface board is suspected. Also check the flat cable between the A21 and A22.
- If only a specific key doesn't work, check first if the key is subsided in the panel.
- If the rotary knob doesn't work, check the A22 board involving the RPG.

To Check the Touch Panel (Option 016 only)

Procedure

By touching the LCD display panel, select or change the setting of a function in the softkey menu and, then, perform the same operation with hardkeys.

- If the touch panel doesn't work correctly whereas the hardkeys function normally, a failure seems in the touch screen controller assembly (5183-4184) or touch-panel LCD assembly (E5070-60102). (The touch panel is not replaceable independently of the LCD.)
- Check the cable between the touch screen controller and the serial interface connector on the A20 digital motherboard.
- If no problem is found in the above checks, a failure in the A20 digital motherboard is suspected.

To Check the LCD

Procedure

- Step 1.** Press **System** key.
- Step 2.** Click **Service Menu** and, then, **Test Menu** in the softkeys menu.
- Step 3.** Click **Display** in the test menu. The whole of the LCD screen turns Red, Green, Blue, White and Black in every 2 seconds and returns to the measurement view. If the color test screen doesn't appear correctly, perform step 4.
- Step 4.** Connect an external VGA monitor to the VIDEO output port on the E5070A/E5071A rear panel.
 - If the monitor screen view is the same as the LCD display, the problem seems in the A26 LCD interface card. Check first if the A26 board is securely connected to the A20 board.
 - If only the LCD display has a problem, check a flat cable between the A26 and A31 LCD connector.
 - If the LCD is not illuminated with backlight, check A52 inverter board and the cable between the A52 and A26. Also check the cables between the A51 LCD and A52.
 - If the cables are normal, check the A51 LCD.

To Check the External Keyboard

Procedure

- Step 1.** Connect the external keyboard to the E5070A/E5071A rear panel connector.
- Step 2.** Turn the instrument on.
- Step 3.** Press **Meas** key.
- Step 4.** Press **↑** and **↓** keys on the external keyboard, and verify that the cursor on the menu bar moves up and down. If it doesn't work, the external keyboard or the A20 digital motherboard may be faulty.

To Check the Mouse

Procedure

- Step 1.** Connect the mouse to the E5070A/E5071A rear panel connector.
- Step 2.** Turn the instrument on.
- Step 3.** Move the mouse and verify that the mouse pointer moves smoothly. If it doesn't move smoothly, check first whether a foreign substance (dust, lint, etc.) is in the track ball hole of the mouse or not.
- Step 4.** Verify that the mouse buttons work normally. If any button doesn't work or the mouse pointer doesn't move, a failure in the mouse or the A20 digital motherboard is suspected.

To Check the FDD

Procedure

- Step 1.** Connect the external keyboard to the E5070A/E5071A rear panel connector.
- Step 2.** Turn the instrument on.
- Step 3.** Insert a 1.44 MB floppy disk, formatted in DOS format, into the FDD slot.
- Step 4.** Press key, and click **Save State** in the menu bar.
- Step 5.** Click **File Dialog...** to open the "Save As" dialog box.
- Step 6.** Select 3 1/2 Floppy [A:] from "Save in" pull-down menu.
- Step 7.** Enter **e5070a** in the file name box from the keyboard.
- Step 8.** Click "Save" button.
- Step 9.** Press key, and click **Recall State** in the menu bar.
- Step 10.** Click **File Dialog...** to open the "Open" dialog box.
- Step 11.** Select 3 1/2 Floppy [A:] from "Look in" pull-down menu.
- Step 12.** Select e5070a file from the file menu or enter **e5070a** in the file name box.
- Step 13.** Click "Open" button.

If the file save or recall operation fails, a failure in the A28 FDD or the flat cable between the A28 and A20 digital motherboard is suspected.

To Check the Video output

Procedure

- Step 1.** Connect an external VGA color monitor to the Video output port on the E5070A/E5071A rear panel.
- Step 2.** Turn the external monitor on.
- Step 3.** Verify that the monitor screen view is the same as the display on the LCD. If the monitor screen view is abnormal, a failure seems in the A26 LCD interface card.

To Check the External Trigger Input

Procedure

- Step 1.** Press key to initialize the E5070A/E5071A.
- Step 2.** Press key.
- Step 3.** Click **Trigger Source** and, then, **External** in the menu bar to set the trigger mode to "External".
- Step 4.** Connect a BNC Short or 50 Ω termination to the Ext Trig connector on the rear panel and

disconnect it. Thereby a measurement trigger should be generated and a measurement result (trace) should be refreshed.

Step 5. If no trigger occurs, a failure in the A21 analog interface board is suspected.

To Check the LAN

Procedure

Step 1. Connect a LAN cable between the LAN port on the rear panel and an external computer (PC).

NOTE

Use a crossed LAN cable to enable the peer-to-peer communication between the E5070A/E5071A and the PC. If the E5070A/E5071A needs to be connected to the PC via a multi port Hub, use a straight LAN cable.

Step 2. Press **[System]** key.

Step 3. Click - **Misc Setup** (for firmware rev 2.0 and above) - **Network Setup** and **Network Device DISABLE** in the softkey menu to change the Network Device setting to "ENABLE". (It doesn't actually change to "Enable" from "Disable" unless the instrument is restarted.)

A dialog box shown in Figure 4-26 will appear to confirm whether you restart the instrument or not.

Figure 4-26

Network device setting change dialog box

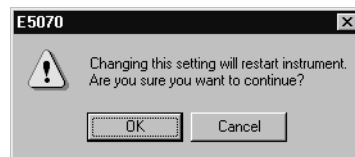

Step 4. Click "OK" button to restart the instrument. Wait until the E5070A/E5071A is shut down and resumes the measurement view.

Step 5. Press **[System]** key and click **Misc Setup - Network Setup**. Confirm that the Network Device setting has been changed to **Network Device ENABLE**.

Step 6. Set up the IP address/subnet mask of the E5070A/E5071A as follows.

a. Click **Network Configuration**. This opens the "Network" dialog box as shown in Figure 4-27.

Figure 4-27 Network dialog box

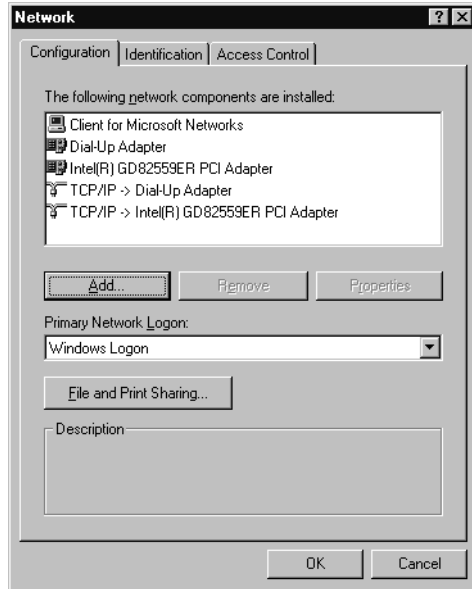

- b. Click "TCP/IP icon in the "Configuration" tab to select it.
- c. Click the "Properties" button. This opens the "TCP/IP Properties" dialog box as shown in Figure 4-28.

Figure 4-28 TCP/IP Properties dialog box (IP Address tab)

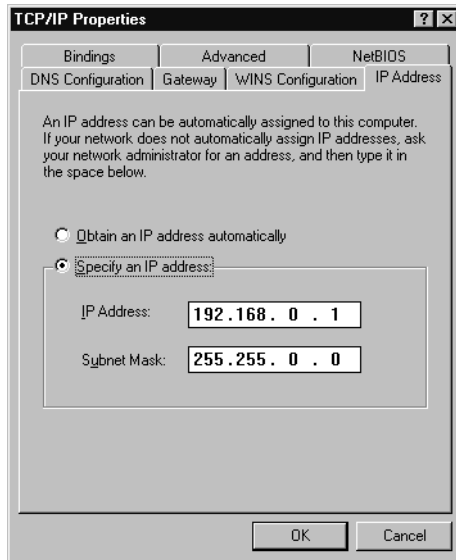

- d. If the IP Address and the Subnet Mask are already assigned, go to step 8. If they are not assigned yet, enter them as follows:

IP Address 192.168.0.1
Subnet Mask 255.255.0.0

To enter a specific IP Address and Subnet Mask, click "Specify an IP address" option button to select it. Input your IP address in the "IP Address" box and your subnet mask in the Subnet Mask box (overwrite the initial values).

NOTE The modified network configuration will not take effect until you shut down once and restart the E5070A/E5071A.

- Step 7.** Shut down the E5070A/E5071A as follows.
- a. Click "OK" button to close the "TCP/IP Properties" dialog box.
 - b. Click "OK" button to close the "Network" dialog box. This opens the "System Settings Change" dialog box as shown in Figure 4-29.

Figure 4-29 System Settings Change dialog box

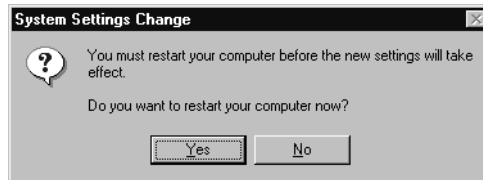

- c. Click "Yes" button to shut down and restart the E5070A/E5071A.

NOTE If you mistakenly clicked "No" button, restart the E5070A/E5071A as follows.

1. Click "Start" and "Shut down..." in the Windows menu bar.
 2. Click the "Restart" button in the "Shut Down Windows" dialog box to select it.
 3. Click "OK" button.
-

- Step 8.** Set up the IP address/subnet mask of the external PC as follows.
- a. Double-click "**My Computer**" icon on Windows desktop of the external PC. And double-click **Control Panel**. The Control Panel window will appear.
 - b. In the Control Panel window, double-click **Network**. The Network dialog box will appear. In the **Configuration** tab, select **TCP/IP** (display it in reverse video) and press the **Properties** button.
 - c. The dialog box appears. If **Specify an IP address** has been selected, record the IP address and subnet mask.
 - d. If the **Obtain an IP address automatically** has been selected, select the **Specify an IP address**. Enter the IP address xxx.xxx.xxx.y and subnet mask xxx.xxx.xxx.xxx as shown in Figure 4-30. The letters x represent the IP address and subnet mask of the E5070A/E5071A. The letter y is different from the IP address of the E5070A/E5071A. Press the **OK** button.

Figure 4-30 Network Dialog Box ("IP Address" Tab)

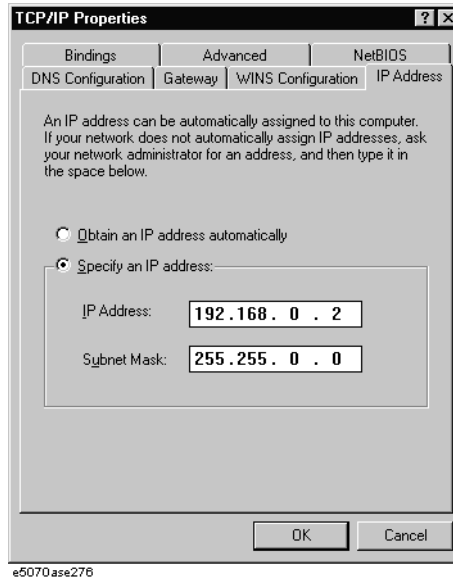

Step 9. By restarting the E5070A/E5071A, the LAN settings take effect. Verify the E5070A/E5071A LAN settings and response to a command from the external computer as follows:

- a. On the external computer, click "Start" button in the Windows Start menu bar using a mouse.
- b. Click "Programs" and "MS-DOS Prompt" (or "Command Prompt") to open the DOS (Command) Prompt window.
- c. Type a ping command followed by the E5070A/E5071A IP address as "ping xxx.xxx.xxx.xxx" (where, xxx.xxx.xxx.xxx is the IP address such as 192.168.0.1 assigned in step 6-d.) Press **Enter** key on the keyboard.
- d. The external computer displays a message of ping command response from the E5070A/E5071A. Figure 4-31 shows an example of normal result that indicates the IP address, packet size, and a response time counted by the computer. The ping command is repeated 4 times.

Figure 4-31 Example of normal ping command test result

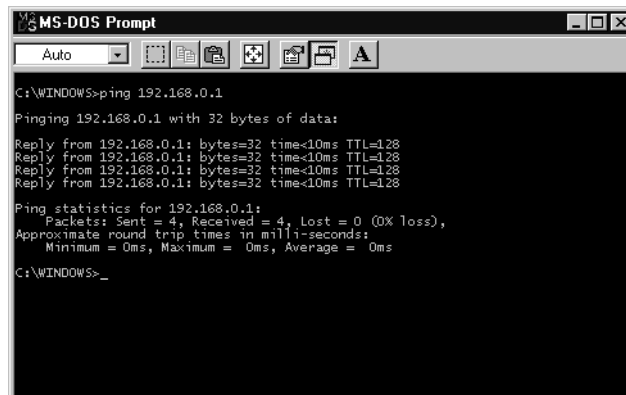

If the E5070A/E5071A doesn't return the response, the external computer displays a message of "Request timed out" as shown in Figure 4-32. In this case, a failure in the A20 digital motherboard is suspected.

Figure 4-32 Example of no response for ping command

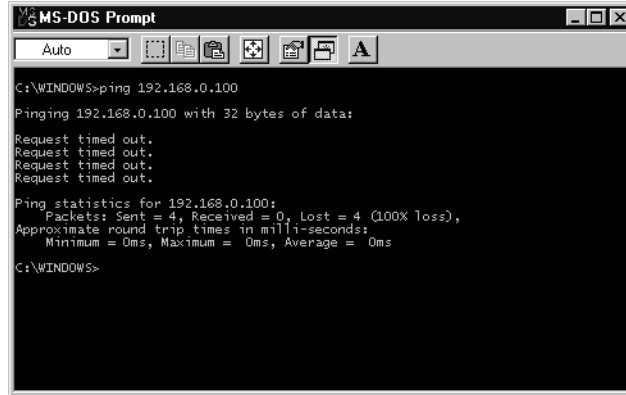

To Check the Printer Parallel Port

Test equipment

It is recommended that the following compatible printers be used.

Manufacturer	Recommended printer (as of February 2002)
Hewlett Packard	DeskJet 930C series
	DeskJet 948C series

Printer cable: Parallel cable

Procedure

- Step 1.** Connect the printer cable between the printer and the E5070A/E5071A printer parallel port. Turn the printer on.
- Step 2.** Press **[Preset]** key to initialize the E5070A/E5071A.
- Step 3.** Press **[System]** key.
- Step 4.** Click **Printer Setup** in the softkey menu.
- Step 5.** Depending on the printer used, select either "hp deskjet 930c" or "hp deskjet 948c" from the pull down menu of the Name box. Then, click "OK" button.
- Step 6.** Click **Print** in the softkey menu. Confirm the printout of the display image.
- Step 7.** If the printer fails to work, the problem seems in the A20 digital motherboard, printer driver or connection of the printer cable.

To Check the GPIB

Procedure

Perform the E5070A/E5071A performance test program. If the controller cannot detect the E5070A/E5071A, the problem seems in the A24 GPIB card or the connection of the GPIB cable.

Troubleshooting Using External Test

External test is the diagnostic test function to supplement the internal test. To enable a diagnosis for the analog measurement blocks uncovered with the internal test, the external test is performed using a coaxial cable, a fixed attenuator, coaxial terminations, a calibration kit and a handler I/O test kit. The following paragraphs describe the procedure to perform the external test.

NOTE

There are two types of the external test dialog box (test menu). This section describes the procedure for each external test dialog box.

- Procedure where the external test revision A.01.01 (or earlier) has been installed.
- Procedure where the internal test revision A.03.00 has been installed.

Contents of the external test

The external test rev. A.01.01(or earlier) contains 13 test groups shown in Table 4-3, the external test rev. A.03.00 contains 7 test groups shown in Table 4-4. Each test group can be performed independently and verifies one of various operating characteristics of the analog measurement section.

Table 4-3 External test group menu (rev. A.01.01 or earlier)

1	Tch Power Gain
2	Tch IF Ranging
3	Receiver Linearity
4	Dynamic Range
5	Trace Noise (Port1)
6	Trace Noise (Port2)
7	Trace Noise (Port3)
8	Trace Noise (Port4)
9	Error Term (Port1)
10	Error Term (Port2)
11	Error Term (Port3)
12	Error Term (Port4)
13	Handler I/O Board

Table 4-4 External test group menu (rev. A.03.00)

1	Tch Power Gain
2	IF Ranging

Table 4-4 External test group menu (rev. A.03.00)

3	Receiver Linearity
4	Dynamic Range
5	Trace Noise
6	Error Term
7	Handler I/O Board

Test equipment required for external test

Table 4-5 shows the equipment required for performing the external test.

Table 4-5 Required equipment

Required test equipment	Qty	Recommended model
Coaxial cable with N type (m) connectors, 61 cm (24 in)	1	N6314A
Fixed attenuator, 10 dB, N(m) - N(f)	1	8491A/B/C
Calibration kit	1	85032F
N-type coaxial Short termination	3	part of 85032F/85054D or part of 85033E/85050D with Type-N adapter
Handler I/O test kit	1	E5070-65001

NOTE Required quantity of Short termination is 3 in addition to one included in the calibration kit.

To Execute the External Test rev. A.01.01 (or earlier)

To isolate faulty board assembly in analog section, execute the external test rev. A.01.01 (or earlier) in accordance with the following procedure. The test procedure needs to be performed using a mouse in addition to the front panel keys.

NOTE To perform the external test properly, the following conditions must be met:

1. Environmental temperature: 23°C ± 5°C
2. Warm-up status indicator in the instrument status bar exhibits "Ready" in blue.

NOTE Do not operate front panel keys, keyboard and mouse during the external test. Changing the instrument settings while the external test is in progress will cause incorrect test results.

Step 1. Connect a mouse to the rear panel connector

- Step 2.** Press **Macro Setup** key.
- Step 3.** Press **↓** - **↓** - **Enter** keys (or click **Load Project**) to select **Load Project** function. "Open" dialog box will be displayed as shown in Figure 4-33.

Figure 4-33

Open dialog box

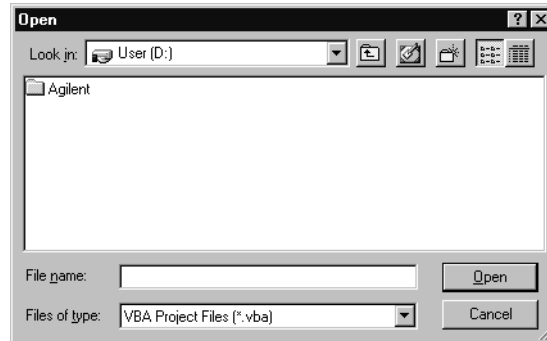

- Step 4.** Select "User [D]" (preset state) from menu in the "Lock in:" box.
- Step 5.** Double-click "Agilent" folder to open it and to access its menu.
- Step 6.** Double-click "Service" folder to open it.
- Step 7.** Click "External Test. VBA" program file to select it from program menu.
- Step 8.** Click "Open" button to download the external test program.
- Step 9.** Press **↓** - **↓** - **↓** - **Enter** (or click **Select Macro**) to select **Select Macro** function.
- Step 10.** Press **Enter** (or click **Module1 main**) to open the **Module1 main** program file. "External Test" dialog box will be displayed as shown in Figure 4-34. This dialog box shows Test List box, which prompts you to select a desired test group from a menu.

Figure 4-34

External test dialog box



- Step 11.** Click **▼** button of the Test List box to view the pull down menu of external test groups. See Figure 4-35. Scroll the menu and find the name of the desired test group. (A complete menu of the external test groups is shown in Table 4-3.)

Figure 4-35 Pull down menu of external test groups

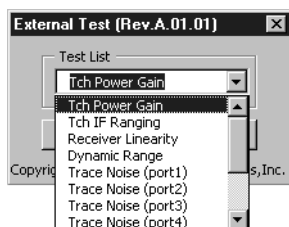

Step 12. To perform the individual tests in each test group, refer to the procedure described below.

Step 13. To end the external test, click "Exit" button in the dialog box.

[1] Tch Power Gain tests

These tests check the source output power along with the test channel receiver gain for each test port.

Required equipment:

Description	Recommended model
Coaxial cable with N type (m) connectors, 61 cm (24 in)	N6314A

Procedure:

Perform the following procedure after step 11.

- a. When ▼ button is clicked, "Tch Power Gain" is selected first (and displayed in blue). If not, click "Tch Power Gain" in the pull down menu.
- b. Click "Test" button in the dialog box to open the "Tch Power Gain" tests dialog box. The dialog box displays the names of 12 independent tests included in the Tch Power Gain tests as shown in Figure 4-36.

Figure 4-36 Tch Power Gain tests dialog box example (E5071A Opt. 413/414)

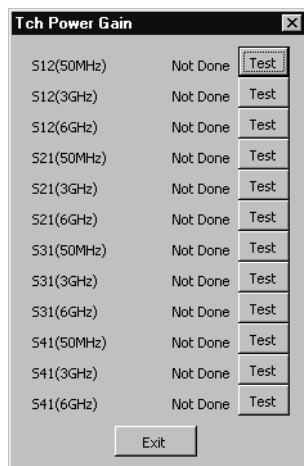

- c. Click the small "Test" button associated with each test. "THRU 1&2" (or "THRU 1&3" or "THRU 1&4") dialog box opens as shown in Figure 4-37.

Figure 4-37 THRU 1&2 dialog box



d. Connect an N-type (m) coaxial cable to the test ports in accordance with Table 4-6.

Table 4-6 Tch Power Gain tests setups

Test name	Objective of the test	Connect an N cable between	Center/Span freq and IFBW settings (Automatic)
S12(50MHz)	Source power for port 2 and test channel receiver gain for port 1	Port 1 and Port2	50 MHz/0 Hz, 10 kHz BW
S12(3GHz)			3 GHz/0 Hz, 10 kHz BW
S12(6GHz) (E5071A)			6GHz/0Hz, 10 kHz BW
S21(50MHz)	Source power for port 1 and test channel receiver gain for port 2	Port 1 and Port 2	50 MHz/0 Hz, 10 kHz BW
S21(3GHz)			3 GHz/0 Hz, 10 kHz BW
S21(6GHz) (E5071A)			6GHz/0Hz, 10 kHz BW
S31(50MHz)	Source power for port 1 and test channel receiver gain for port 3 (Opt. 313/314/413/414)	Port 1 and Port 3	50 MHz/0 Hz, 10 kHz BW
S31(3GHz)			3 GHz/0 Hz, 10 kHz BW
S31(6GHz) (E5071A)			6GHz/0Hz, 10 kHz BW
S41(50MHz)	Source power for port 1 and test channel receiver gain for port 4 (Opt. 413/414)	Port 1 and Port 4	50 MHz/0 Hz, 10 kHz BW
S41(3GHz)			3 GHz/0 Hz, 10 kHz BW
S41(6GHz) (E5071A)			6GHz/0Hz, 10 kHz BW

NOTE RF output power is 0 dBm and Nop is 101 for all the tests shown in the table.

- e. Click "OK" button to run the test program. The dialog box displays "Now testing..." while the Tch Power Gain tests are in progress.
- f. When the tests are completed, the dialog box displays Pass or Fail for each test as shown in Figure 4-38.

Figure 4-38 Power Gain test results display example (E5071A Opt. 413/414)

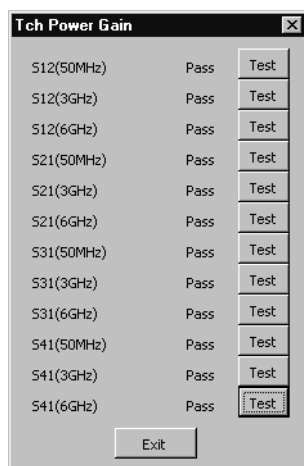

- g. If at least one of the Tch Power Gain tests failed, refer to Table 4-20 External Test Failure Troubleshooting Information.
- h. To return to the External Test dialog box, click "Exit" button.

[2] Tch IF Ranging tests

These tests check the IF signal level ranging operation of test channel receiver for each test port.

Required equipment:

Description	Recommended model
Fixed attenuator, 10 dB, N(m) - N(f)	8491A/B/C
Coaxial cable with N type (m) connectors, 61 cm (24 in)	N6314A

Procedure:

Perform the following procedure after step 11.

- a. Click "Tch IF Ranging" in the pull down menu of the Test List box.
- b. Click "Test" button in the dialog box to open the "IF Ranging" tests dialog box. The dialog box displays 4 independent tests included in the IF Ranging tests, as shown in Figure 4-39.

Figure 4-39 IF Ranging tests dialog box example (E5070A/E5071A Opt. 413/414)

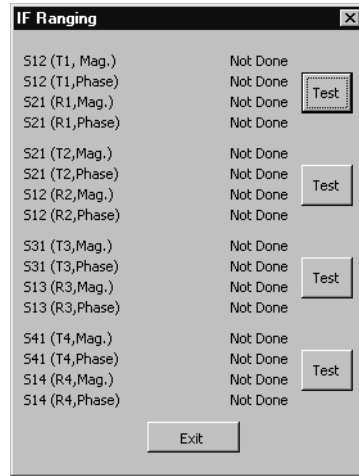

- c. Click the "Test" button associated with each test. "10dB 1&2" (or "10dB 1&3" or "10dB 1&4") dialog box opens as shown in Figure 4-40.

Figure 4-40 10dB 1&2 dialog box



- d. Connect a 10 dB fixed attenuator and an N-type (m) coaxial cable in series between the test ports in accordance with Table 4-7. Make the connection as shown in Figure 4-41.

Figure 4-41 10 dB attenuator and cable connection (E5070A/E5071A Opt. 413/414)

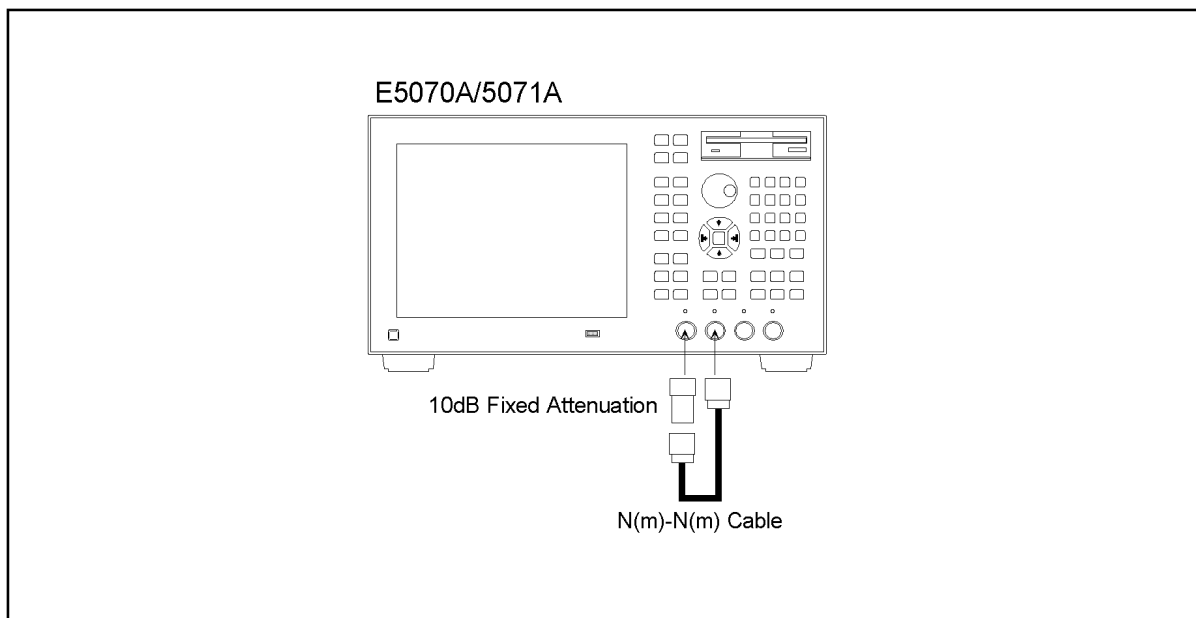

e5070ase159

Table 4-7 Tch Power Gain tests setups

Test name	Objective of the test	Connect a 10 dB attenuator and an N cable between	Center/Span freq, IFBW, Nop and RF power settings (Automatic)
S12 (T1, Mag) S12 (T1, Phase) S21 (R1, Mag) S21 (R1, Phase)	IF signal level ranging operation of test channel receiver for Port 1	Port 1 and Port 2	50 MHz/0 Hz, 1 kHz BW, 101, -15 dBm
S21 (T2, Mag) S21 (T2, Phase) S12 (R2, Mag) S12 (R2, Phase)	IF signal level ranging operation of test channel receiver for Port 2	Port 1 and Port 2	50 MHz/0 Hz, 1 kHz BW, 101, -15 dBm
S31 (T3, Mag) S31 (T3, Phase) S13 (R3, Mag) S13 (R3, Phase)	IF signal level ranging operation of test channel receiver for Port 3 (Opt. 313/314/413/414)	Port 1 and Port 3	50 MHz/0 Hz, 1 kHz BW, 101, -15 dBm
S41 (T4, Mag) S41 (T4, Phase) S14 (R4, Mag) S14 (R4, Phase)	IF signal level ranging operation of test channel receiver for Port 4 (Opt. 413/414)	Port 1 and Port 4	50 MHz/0 Hz, 1 kHz BW, 101, -15 dBm

- e. Click "OK" button to run the test program. The dialog box displays "Now testing..." while the Tch IF Ranging tests are in progress.
- f. When the tests are completed, the dialog box displays Pass or Fail for each test as shown in Figure 4-42.

Figure 4-42

Tch IF Ranging test results display example (E5070A/E5071A Opt. 413/414)

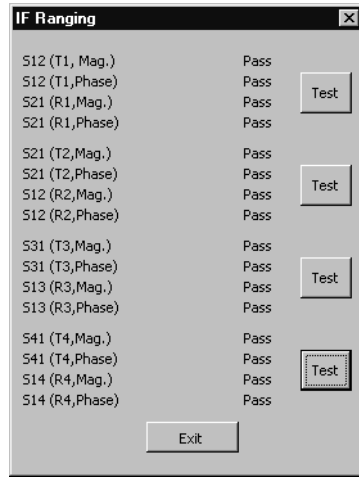

- g. If at least one of the Tch IF Ranging tests failed, refer to Table 4-20 External Test Failure Troubleshooting Information.
- h. To return to the External Test dialog box, click "Exit" button.

[3] Receiver Linearity tests

These tests check the linearity (gain compression) of test channel receiver for each test port.

Required equipment:

Description	Recommended model
Coaxial cable with N type (m) connectors, 61 cm (24 in)	N6314A

Procedure:

Perform the following procedure after step 11.

- a. Click "Receiver Linearity" in the pull down menu of the Test List box.
- b. Click "Test" button in the dialog box to open the "Receiver Linearity" tests dialog box. The dialog box displays 4 independent tests included in the Receiver Linearity tests, as shown in Figure 4-43.

Figure 4-43

Receiver Linearity tests dialog box example (E5070A/E5071A Opt. 413/414)

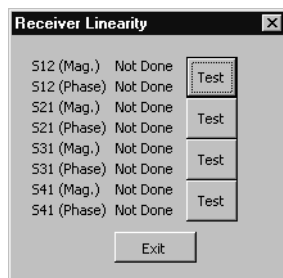

- c. Click the "Test" button associated with each test. "THRU 1&2" (or THRU 1&3" or

4. Troubleshooting

Troubleshooting
Troubleshooting Using External Test

"THRU 1&4") dialog box opens as shown in Figure 4-44.

Figure 4-44 THRU 1&2 dialog box



- d. Connect an N-type (m) coaxial cable between the test ports in accordance with Table 4-8.

Table 4-8 Receiver Linearity test setups

Test name	Objective of the test	Connect an N cable between	Sweep freq span, IFBW, Nop and RF power settings (Automatic)
S12 (Mag) S12 (Phase)	Receiver linearity for Port 1	Port 1 and Port 2	Full span, 10 kHz BW, 201, -10 dBm and 0 dBm
S21 (Mag) S21 (Phase)	Receiver linearity for Port 2	Port 1 and Port 2	Full span, 10 kHz BW, 201, -10 dBm and 0 dBm
S31 (Mag) S31 (Phase)	Receiver linearity for Port 3 (Opt. 313/314/413/414)	Port 1 and Port 3	Full span, 10 kHz BW, 201, -10 dBm and 0 dBm
S41 (Mag) S41 (Phase)	Receiver linearity for Port 4 (Opt. 413/414)	Port 1 and Port 4	Full span, 10 kHz BW, 201, -10 dBm and 0 dBm

- e. Click "OK" button to run the test program. The dialog box displays "Now testing..." while the Receiver Linearity tests are in progress.
- f. When the tests are completed, the dialog box displays Pass or Fail for each test as shown in Figure 4-45.

Figure 4-45 Receiver Linearity test results example (E5070A/E5071A Opt. 413/414)

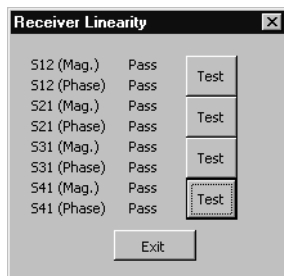

- g. If at least one of the Receiver Linearity tests failed, refer to Table 4-20 External Test Failure Troubleshooting Information.
- h. To return to the External Test dialog box, click "Exit" button.

[4] Dynamic Range tests

These tests check the dynamic range of test channel receiver for each test port.

Required equipment:

Description	Recommended model
N-type coaxial Short termination (4 ea.)	part of 85032F/85054D or part of 85033E/85050D with Type-N adapter

Procedure:

Perform the following procedure after step 11.

- a. Click "Dynamic Range" in the pull down menu of the Test List box.
- b. Click "Test" button in the dialog box to open the "Dynamic Range" tests dialog box.
 The dialog box displays a matrix of S-parameter settings and test frequency ranges as shown in Figure 4-46. The Dynamic Range tests are performed sequentially for all the test ports (receiver channels).

Figure 4-46

Dynamic Range tests dialog box example (E5071A Opt. 413/414)

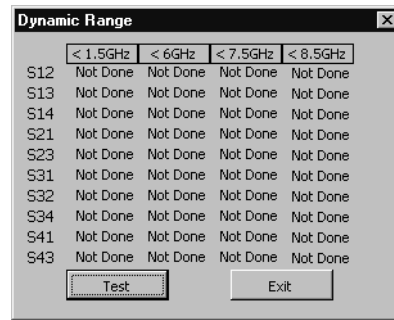

- c. Click "Test" button in the dialog box. Then "SHORT (all ports)" dialog box opens as shown in Figure 4-47.

Figure 4-47

SHORT (all ports) dialog box



- d. Connect N-type Short terminations to all the test ports.

NOTE For more information on the Dynamic Range tests setup, see Table 4-9.

Table 4-9 Dynamic Range tests setup

Test parameter	Connect Short terminations to	Sweep freq span, IFBW, Nop and RF power settings (Automatic)
S12 S13 (Opt. 313/314/413/414) S14 (Opt. 413/414) S21 S23 (Opt. 313/314/413/414) S31 (Opt. 313/314/413/414) S32 (Opt. 313/314/413/414) S34 (Opt. 413/414) S41 (Opt. 413/414) S43 (Opt. 413/414)	All the test ports	3 MHz to 3 GHz (E5070A), 3 MHz to 8.5 GHz (E5071A), 3 kHz BW, 101, 0 dBm

- e. Click "OK" button to run the test program. The dialog box displays "Now testing..." while the Dynamic Range tests are in progress.
- f. When the tests are completed, the dialog box displays Pass or Fail for each test as shown in Figure 4-48.

Figure 4-48 Dynamic Range test results example (E5071A Opt. 413/414)

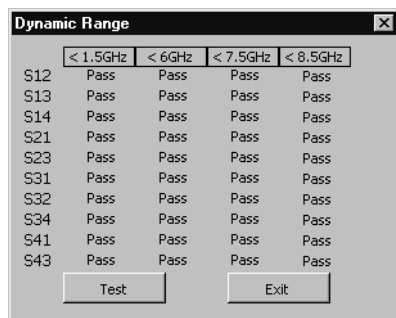

- g. If at least one of the Dynamic Range tests failed, refer to Table 4-20 External Test Failure Troubleshooting Information.
- h. To return to the External Test dialog box, click "Exit" button.

[5] Trace Noise (port 1) tests

These tests check the trace noise levels for Port 1.

Required equipment:

Description	Recommended model
N-type coaxial Short termination	part of 85032F/85054D or part of 85033E/85050D with Type-N adapter

Procedure:

Perform the following procedure after step 11.

- a. Click "Trace Noise (Port 1)" in the pull down menu of the Test List box.
- b. Click "Test" button in the dialog box to open the "Trace Noise (port 1)" tests dialog box. The dialog box displays the selected S-parameter and test frequencies as shown in Figure 4-49.

Figure 4-49 Trace Noise (port 1) tests dialog box example (E5071A)

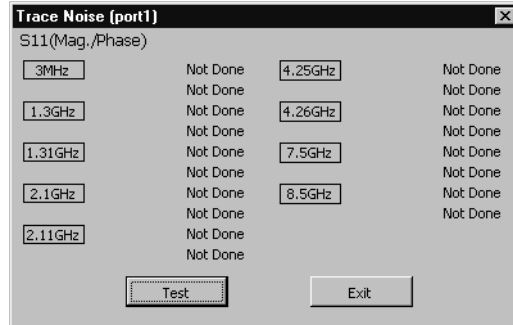

- c. Click "Test" button in the dialog box. Then "SHORT (port 1)" dialog box opens as shown in Figure 4-50.

Figure 4-50 SHORT (port 1) dialog box



- d. Connect an N-type Short termination to Port 1.

NOTE

For more information on the Trace Noise (port 1) tests setup, see Table 4-10.

Table 4-10 Trace Noise (port 1) tests setup

Test parameter	Connect Short termination to	Test frequency points, IFBW, Nop and RF power settings (Automatic)
S11 (Mag./Phase)	Port 1	3 MHz, 1.3 GHz, 1.31 GHz, 2.1 GHz and 2.11 GHz (5070A), 3 MHz, 1.3 GHz, 1.31 GHz, 2.1 GHz, 2.11 GHz, 4.25 GHz, 4.26 GHz, 7.5 GHz and 8.5 GHz (E5070A), 3 kHz BW, 101,0 dBm

- e. Click "OK" button to run the test program. The dialog box displays "Now testing..." while the Trace Noise (port 1) tests are in progress.
- f. When the tests are completed, the dialog box displays Pass or Fail for each test as shown in Figure 4-51.

Figure 4-51 Trace Noise (port 1) test results example (E5071A)

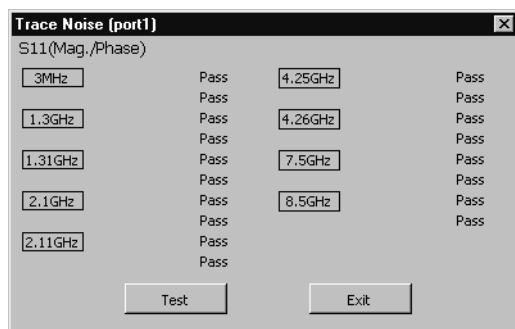

- g. If at least one of the Trace Noise (port 1) tests failed, refer to Table 4-20 External Test Failure Troubleshooting Information.
- h. To return to the External Test dialog box, click "Exit" button.

[6] Trace Noise (port 2) tests

[7] Trace Noise (port 3) tests

[8] Trace Noise (port 4) tests

These tests check the trace noise levels for Port 2, Port 3 and Port 4.

NOTE

Trace Noise (port 3) tests apply to Option 313/314/413/414 instruments only.

Trace Noise (port 4) tests apply to Option 413/414 instruments only.

Required equipment:

Same as the Trace Noise (port 1) tests.

Procedure:

Perform the same test procedure as the Trace Noise (port 1) tests. The port number of the dialog boxes and the test port where the Short termination is connected change as shown in Table 4-11.

Table 4-11 Trace Noise tests setups and procedures

Test item	Port number of dialog boxes	Connect Short termination to
Trace Noise (port 2)	port 2	Port 2
Trace Noise (port 3)	port 3	Port 3
Trace Noise (port 4)	port 4	Port 4

[9] Error Term (port 1) tests

These tests check the reflection tracking, directivity and source match for Port 1.

Required equipment:

Description	Recommended model
Calibration kit (N-type Open, Short and 50Ω Load terminations)	85032F

Procedure:

Perform the following procedure after step 11.

- a. Click "Error Term (port 1)" in the pull down menu of the Test List box.
- b. Click "Test" button in the dialog box to open the "Error Term (port 1)" tests dialog box. The dialog box displays some test frequency ranges, where the source match, directivity and reflection tracking are tested, as shown in Figure 4-52.

Figure 4-52

Error Term (port 1) tests dialog box example (E5071A)

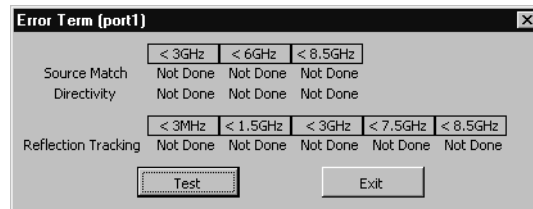

- c. Click "Test" button to run the test program. The dialog box displays "Now testing..." for a few seconds. Then "OPEN (port 1)" dialog box opens as shown in Figure 4-53.

Figure 4-53

OPEN (port 1) dialog box



- d. Connect an N-type Open termination to Port 1.

NOTE

For more information on Error Term (port 1) tests setup, see Table 4-12.

Table 4-12

Error Term (port 1) tests setup

Test parameter	Connect	Sweep freq span, IFBW, Nop and RF power settings, System correction (Automatic)
Source match	Open to Port 1	Full span, 100 Hz BW, 201, 0 dBm, System correction OFF
Directivity	Short to Port 1	
Reflection tracking	Load to Port 1	

- e. Click "OK" button to continue the test. The "Error Term (port 1)" dialog box displays "Now calibrating..." for a few seconds. Wait until "SHORT (port 1)" dialog box opens.

Troubleshooting
Troubleshooting Using External Test

- f. Connect an N-type Short termination to Port 1.
- g. Click "OK" button to continue the test and wait until "LOAD (port 1)" dialog box opens.
- h. Connect a 50 Ω Load termination to Port 1.
- i. Click "OK" button to continue the test and wait for a few seconds.
- j. When the tests are completed, the "Error Term (port 1)" dialog box displays Pass or Fail for each test as shown in Figure 4-54.

Figure 4-54 Error Term (port 1) test results example (E5071A)

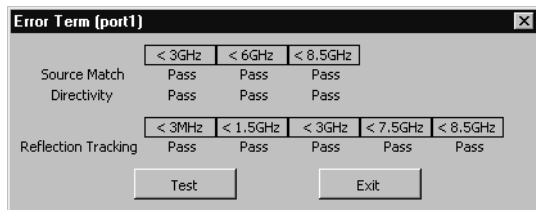

- k. If at least one of the Error Term (port 1) tests failed, refer to Table 4-20 External Test Failure Troubleshooting Information.
- l. To return to the External Test dialog box, click "Exit" button.

[10] Error Term (port 2) tests

[11] Error Term (port 3) tests

[12] Error Term (port 4) tests

These tests check the reflection tracking, directivity and source match for Port 2, Port 3 and Port 4.

NOTE

Error Term (port 3) tests apply to Option 313/314/413/414 instruments only.

Error Term (port 4) tests apply to Option 413/414 instruments only.

Required equipment:

Same as the Error Term (port 1) tests.

Procedure:

Perform the same test procedure as the Error Term (port 1) tests. The port number of the dialog boxes and the test port where the Open, Short and Load terminations are connected change as shown in Table 4-13.

Table 4-13 Error Term tests setups and procedures

Test item	Port number of dialog boxes	Connect Open, Short and Load terminations to
Error Term (port 2)	port 2	Port 2
Error Term (port 3)	port 3	Port 3
Error Term (port 4)	port 4	Port 4

[13] Handler I/O Board tests

These tests check the function of Handler I/O board for interfacing with an external component handler. The tests are performed using a handler I/O test kit as a substitute for the handler.

Required equipment:

Description	Recommended model
Handler I/O test kit	E5070-65001

Procedure:

Perform the following procedure after step 11.

- a. Click "Handler I/O Board" in the pull down menu of the Test List box.
- b. Click "Test" button in the dialog box. Then "Handler I/O Board" tests dialog box opens as shown in Figure 4-55.

Figure 4-55

Handler I/O Board tests dialog box



- c. Click the "Test" button in the dialog box. A message of "Connect Handler I/O Test Kit" will be displayed.
- d. Connect the handler I/O test kit to the Handler I/O connector on the rear panel.
- e. Click "OK" button. The dialog box displays "Now testing..." while the Handler I/O Board test is in progress.
- f. When the tests are completed, the dialog box displays Pass or Fail of test result as shown in Figure 4-56.

Figure 4-56

Handler I/O Board test result example

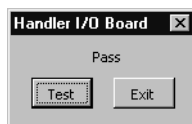

- g. If the Handler I/O Board test failed, refer to Table 4-20 External Test Failure Troubleshooting Information.
- h. To return to the External Test dialog box, click "Exit" button.

NOTE

To end the external test, click "Exit" button in the "External Test" dialog box.

To Execute the External Test rev. A.03.00

To isolate faulty board assembly in analog section, execute the external test rev. A.03.00 in accordance with the following procedure. The test procedure needs to be performed using a mouse in addition to the front panel keys.

NOTE To perform the external test properly, the following conditions must be met:

1. Environmental temperature: $23^{\circ}\text{C} \pm 5^{\circ}\text{C}$
2. Warm-up status indicator in the instrument status bar exhibits "Ready" in blue.

NOTE Do not operate front panel keys, keyboard and mouse during the external test. Changing the instrument settings while the external test is in progress will cause incorrect test results.

Step 1. Connect a mouse to the rear panel connector

Step 2. Press **Macro Run** key.

Step 3. Press **↓** - **↓** - **Enter** keys (or click **Load Project**) to select **Load Project** function. "Open" dialog box will be displayed as shown in Figure 4-57.

Figure 4-57

Open dialog box

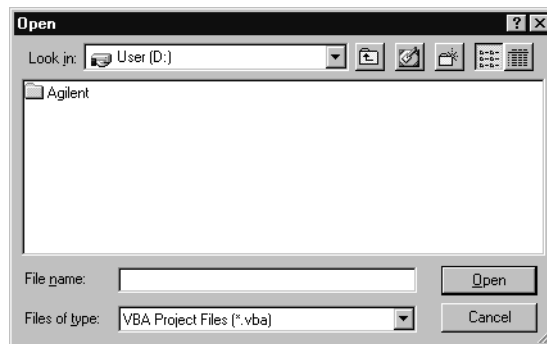

Step 4. Select "User [D]" (preset state) from menu in the "Lock in:" box.

Step 5. Double-click "Agilent" folder to open it and to access its menu.

Step 6. Double-click "Service" folder to open it.

Step 7. Click "External Test. VBA" program file to select it from program menu.

Step 8. Click "Open" button to download the external test program.

Step 9. Press **↓** - **↓** - **↓** - **Enter** (or click **Select Macro**) to select **Select Macro** function.

Step 10. Press **Enter** (or click **Module1 main**) to open the **Module1 main** program file. "External Test" window will be displayed as shown in Figure 4-58. This window shows the test items and their results.

Figure 4-58

External Test Window

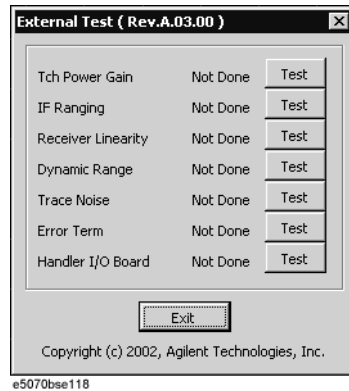

Step 11. To perform the individual tests in each test group, refer to the procedure described below.

Step 12. To end the external test, click "Exit" button in the dialog box.

[1] Tch Power Gain tests

These tests check the source output power along with the test channel receiver gain for each test port.

Required equipment:

Description	Recommended model
Coaxial cable with N type (m) connectors, 61 cm (24 in)	N6314A

Procedure:

Perform the following procedure after Step 11.

- a. Click "Test" button in the right of "Tch Power Gain" in the window to open the "Tch Power Gain" window. The window displays the S parameters and frequencies as the test points. Their results are displayed in the matrix.(Figure 4-59)

Figure 4-59

Tch Power Gain tests dialog box example (E5071A Opt. 413/414)

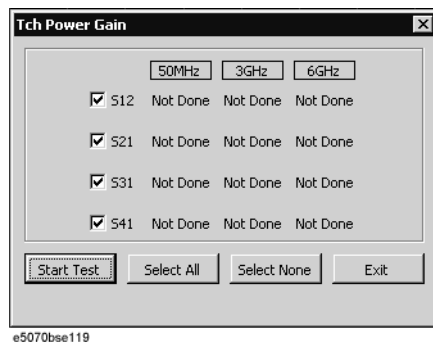

- b. Select the S parameter for the test by clicking the check boxes. Click the "Start Test" button. The instruction dialog box opens as shown in Figure 4-60. Follow the instruction.

4. Troubleshooting

NOTE Clicking “Select All” button checks all the check box. Clicking "Select None" button clears all the check boxes. Click "Exit" to return to the External Test dialog box

Figure 4-60 THRU 1&2 dialog box

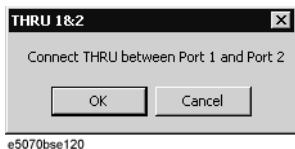

c. Connect an type-N (m) coaxial cable to the test ports in accordance with Table 4-14.

Table 4-14 Tch Power Gain tests setups

Test name	Objective of the test	Connect an N cable between	Freq and IFBW settings (Automatic)
S12	Source power for port 2 and test channel receiver gain for port 1	Port 1 and Port2	50 MHz/3 GHz/6GHz, 10 kHz BW
S21	Source power for port 1 and test channel receiver gain for port 2	Port 1 and Port 2	50 MHz/3 GHz/6GHz, 10 kHz BW
S31	Source power for port 1 and test channel receiver gain for port 3 (Opt. 313/314/413/414)	Port 1 and Port 3	50 MHz/3 GHz/6GHz, 10 kHz BW
S41	Source power for port 1 and test channel receiver gain for port 4 (Opt. 413/414)	Port 1 and Port 4	50 MHz/3 GHz/6GHz, 10 kHz BW

NOTE RF output power is 0 dBm and Nop is 101 for all the tests shown in the table.

- d. Click "OK" button to run the test program. The dialog box displays "Now testing..." while the Tch Power Gain tests are in progress.
- e. When the tests are completed, the dialog box displays Pass or Fail for each test as shown in Figure 4-61.

Figure 4-61 Power Gain test results display example (E5071A Opt. 413/414)

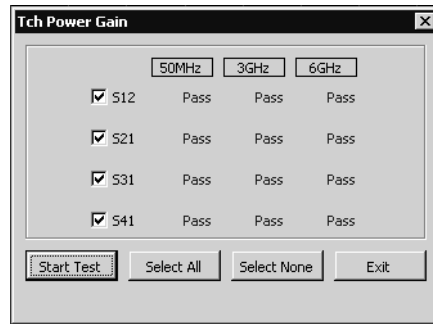

e5070bse121

- f. If at least one of the Tch Power Gain tests failed, refer to Table 4-20 External Test Failure Troubleshooting Information.
- g. To return to the External Test dialog box, click "Exit" button.

[2] Tch IF Ranging tests

These tests check the IF signal level ranging operation of test channel receiver for each test port.

Required equipment:

Description	Recommended model
Fixed attenuator, 10 dB, N(m) - N(f)	8491A/B/C

Figure 4-62 IF Ranging tests dialog box example (E5070A/E5071A Opt. 413/414)

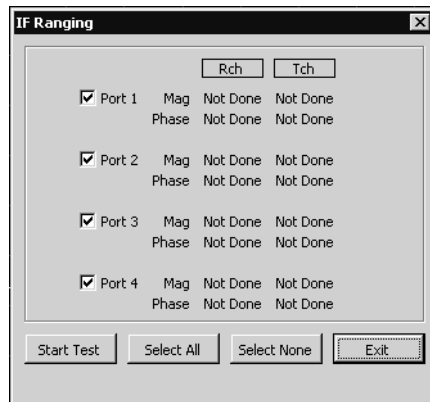

e5070bse122

- b. Select the port numbers for the test by clicking the check boxes. Then, click "Start Test" button. The instruction dialog box opens as shown in Figure 4-63. Follow the instruction.

NOTE

Clicking "Select All" button checks all the check boxes. Clicking "Select None" button clears all the check boxes. Click "Exit" to return to the External Test dialog box

Figure 4-63 10dB 1&2 dialog box

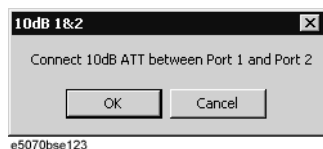

- c. Connect a 10 dB fixed attenuator and an type-N (m) coaxial cable in series between the test ports in accordance with Table 4-15. Make the connection as shown in Figure 4-64.

Figure 4-64 10 dB attenuator and cable connection (E5070A/E5071A Opt. 413/414)

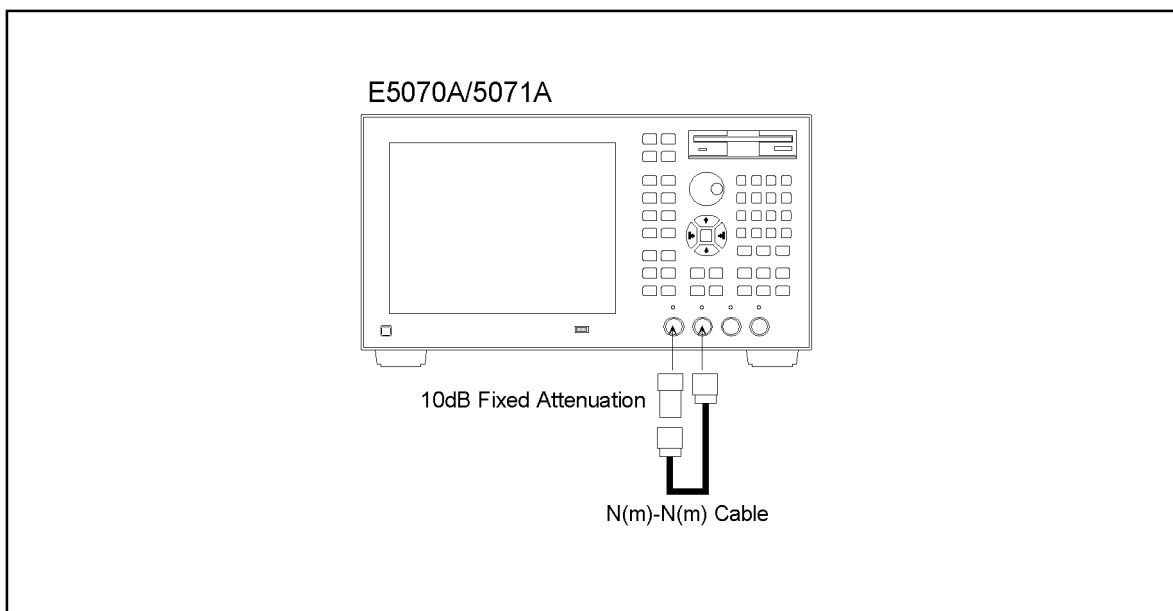

e5070ase159

Table 4-15 Tch IF Ranging tests setups

Test name	Objective of the test	Connect a 10 dB attenuator and an N cable between	Center/Span freq, IFBW, Nop and RF power settings (Automatic)
Port 1	IF signal level ranging operation of test channel receiver for Port 1	Port 1 and Port 2	50 MHz/0 Hz, 1 kHz BW, 101, -15 dBm
Port 2	IF signal level ranging operation of test channel receiver for Port 2	Port 1 and Port 2	50 MHz/0 Hz, 1 kHz BW, 101, -15 dBm
Port 3	IF signal level ranging operation of test channel receiver for Port 3 (Opt. 313/314/413/414)	Port 1 and Port 3	50 MHz/0 Hz, 1 kHz BW, 101, -15 dBm
Port 4	IF signal level ranging operation of test channel receiver for Port 4 (Opt. 413/414)	Port 1 and Port 4	50 MHz/0 Hz, 1 kHz BW, 101, -15 dBm

- d. Click "OK" button to run the test program. The dialog box displays "Now testing..." while the Tch IF Ranging tests are in progress.

- e. When the tests are completed, the dialog box displays Pass or Fail for each test as shown in Figure 4-65.

Figure 4-65

Tch IF Ranging test results display example (E5070A/E5071A Opt. 413/414)

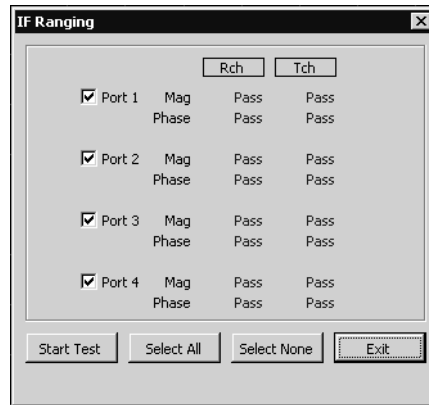

e5070bse124

- f. If at least one of the Tch IF Ranging tests failed, refer to Table 4-20 External Test Failure Troubleshooting Information.
- g. To return to the External Test dialog box, click "Exit" button.

[3] Receiver Linearity tests

These tests check the linearity (gain compression) of test channel receiver for each test port.

Required equipment:

Description	Recommended model
Coaxial cable with type-N (m) connectors, 61 cm (24 in)	N6314A

Procedure:

Perform the following procedure after Step 11.

- a. Click "Test" button in the right of "Receiver Linearity" in the window to open the "Receiver Linearity" window. The window displays the port number and receiver channel as the test points. The result for each S parameter is displayed as the 4x2 matrix.(Figure 4-66).

Figure 4-66 Receiver Linearity tests dialog box example (E5070A/E5071A Opt. 413/414)

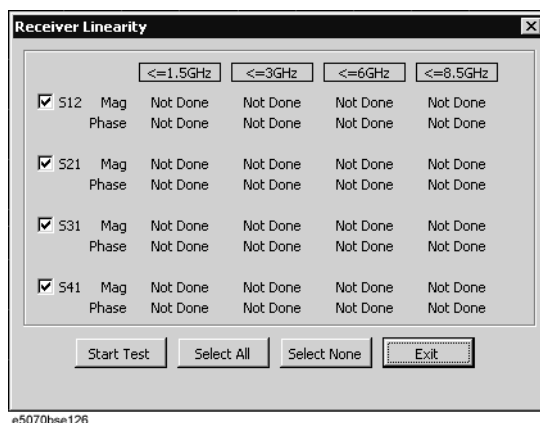

- b. Select the S parameters for the test by clicking the check boxes. Then, click “Start Test” button. The instruction dialog box opens as shown in Figure 4-67. Follow the instruction.

NOTE

Clicking “Select All” button checks all the check boxes. Clicking "Select None" button clears all the check boxes. Click "Exit" to return to the External Test dialog box

Figure 4-67 THRU 1&2 dialog box

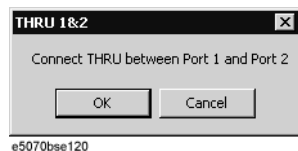

- c. Connect an type-N (m) coaxial cable between the test ports in accordance with Table 4-16.

Table 4-16 Receiver Linearity test setups

Test name	Objective of the test	Connect an N cable between	Sweep freq span, IFBW, Nop and RF power settings (Automatic)
S12	Receiver linearity for Port 1	Port 1 and Port 2	Full span, 10 kHz BW, 201, -10 dBm and 0 dBm
S21	Receiver linearity for Port 2	Port 1 and Port 2	Full span, 10 kHz BW, 201, -10 dBm and 0 dBm
S31	Receiver linearity for Port 3 (Opt. 313/314/413/414)	Port 1 and Port 3	Full span, 10 kHz BW, 201, -10 dBm and 0 dBm
S41	Receiver linearity for Port 4 (Opt. 413/414)	Port 1 and Port 4	Full span, 10 kHz BW, 201, -10 dBm and 0 dBm

- d. Click "OK" button to run the test program. The dialog box displays "Now testing..." while the Receiver Linearity tests are in progress.
- e. When the tests are completed, the dialog box displays Pass or Fail for each test as

shown in Figure 4-68.

Figure 4-68 Receiver Linearity test results example (E5070A/E5071A Opt. 413/414)

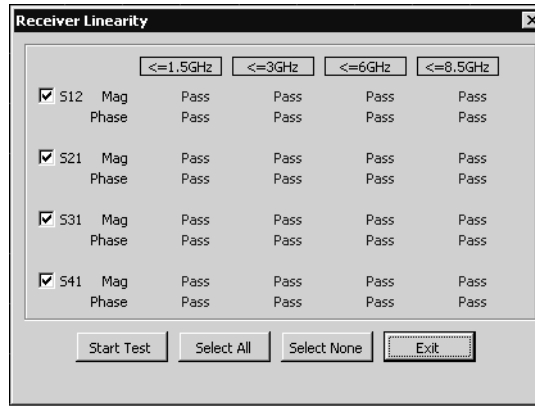

- f. If at least one of the Receiver Linearity tests failed, refer to Table 4-20 External Test Failure Troubleshooting Information.
- g. To return to the External Test dialog box, click "Exit" button.

[4] Dynamic Range tests

These tests check the dynamic range of test channel receiver for each test port.

Required equipment:

Description	Recommended model
Type-N coaxial Short termination (4 ea.)	part of 85032F/85054D or part of 85033E/85050D with Type-N adapter

Procedure:

Perform the following procedure after Step 11.

- a. Click "Test" button in the right of "Dynamic Range" in the window to open the "Dynamic Range" window. The window displays the S parameters and frequency as the test points. The results are displayed as matrix.(Figure 4-69).

Figure 4-69 Dynamic Range tests dialog box example (E5071B Opt. 413/414)

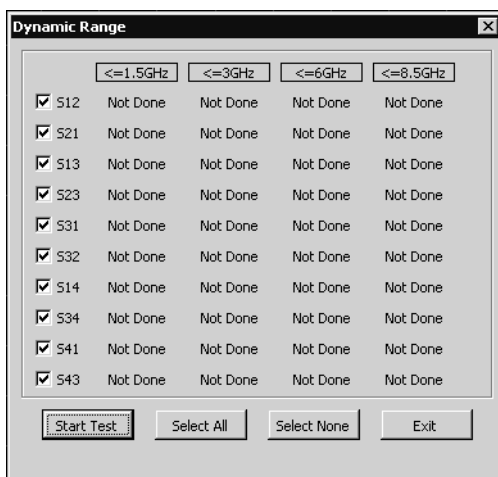

e5070bse127

- b. Select the S parameters for the test by clicking the check boxes. Then, click “Start Test” button. The instruction dialog box opens as shown in Figure 4-70. Follow the instruction.

NOTE

Clicking “Select All” button checks all the check boxes. Clicking "Select None" button clears all the check boxes. Click "Exit" to return to the External Test dialog box

Figure 4-70 SHORT (all ports) dialog box

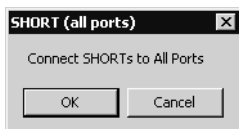

e5070bse128

- c. Connect type-N Short terminations to all the test ports.

NOTE

For more information on the Dynamic Range tests setup, see Table 4-17.

Table 4-17 Dynamic Range tests setup

Test parameter	Connect Short terminations to	Sweep freq span, IFBW, Nop and RF power settings (Automatic)
S12 S13 (Opt. 313/314/413/414) S14 (Opt. 413/414) S21 S23 (Opt. 313/314/413/414) S31 (Opt. 313/314/413/414) S32 (Opt. 313/314/413/414) S34 (Opt. 413/414) S41 (Opt. 413/414) S43 (Opt. 413/414)	All the test ports	3 MHz to 3 GHz (E5070A), 3 MHz to 8.5 GHz (E5071A), 3 kHz BW, 101, 0 dBm

- d. Click "OK" button to run the test program. The dialog box displays "Now testing..." while the Dynamic Range tests are in progress.
- e. When the tests are completed, the dialog box displays Pass or Fail for each test as shown in Figure 4-71.

Figure 4-71

Dynamic Range test results example (E5071A Opt. 413/414)

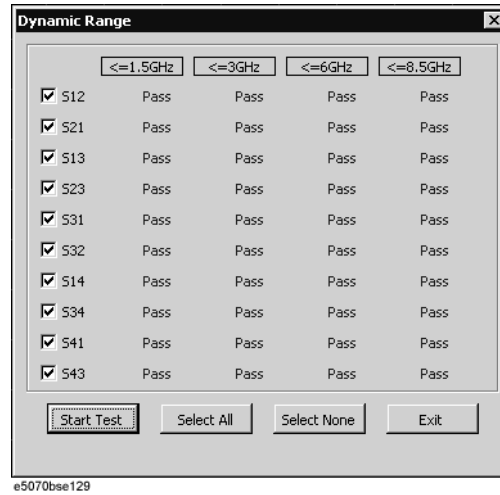

- f. If at least one of the Dynamic Range tests failed, refer to Table 4-20 External Test Failure Troubleshooting Information.
- g. To return to the External Test dialog box, click "Exit" button.

[5] Trace Noise tests

These tests check the trace noise levels for the selected test ports.

Required equipment:

Description	Recommended model
Type-N coaxial Short termination. (4 ea)	part of 85032F/85054D or part of 85033E/85050D with Type-N adapter

Procedure:

Perform the following procedure after Step 11.

- a. Click "Test" button in the right of "Trace Noise" in the window to open the "Trace Noise" window. The window displays the S parameters and frequencies as the test points. The result for each S parameter is displayed as the 9x2 matrix.(Figure 4-72).

Figure 4-72 Trace Noise tests dialog box example (E5071A)



- b. Select the S parameter for the test by clicking the check boxes. Then, click “Start Test” button. The instruction dialog box opens as shown in Figure 4-73. Follow the instruction.

NOTE Clicking “Select All” button checks all the check boxes. Clicking "Select None" button clears all the check boxes. Click "Exit" to return to the External Test dialog box

Figure 4-73 SHORT (all ports) dialog box



- c. Connect an type-N Short termination to all the test ports.

NOTE For more information on the Trace Noise tests setup, see Table 4-18.

Table 4-18 Trace Noise tests setup

Test parameter	Connect Short termination to	Test frequency points, IFBW, Nop, RF power settings and Sweep delay(Automatic)
S11	All test ports	3 MHz, 1.3 GHz, 1.31 GHz, 2.1 GHz and 2.11 GHz (E5070A), 3 MHz, 1.3 GHz, 1.31 GHz, 2.1 GHz, 2.11 GHz, 4.25 GHz, 4.26 GHz, 7.5 GHz and 8.5 GHz (E5071A), 3 kHz BW, 101, 0 dBm, 100 ms
S22		
S33		
S44		

- d. Click "OK" button to run the test program. The dialog box displays "Now testing..." while the Trace Noise (port 1) tests are in progress.
- e. When the tests are completed, the dialog box displays Pass or Fail for each test as shown in Figure 4-74.

Figure 4-74 Trace Noise test results example (E5071A)

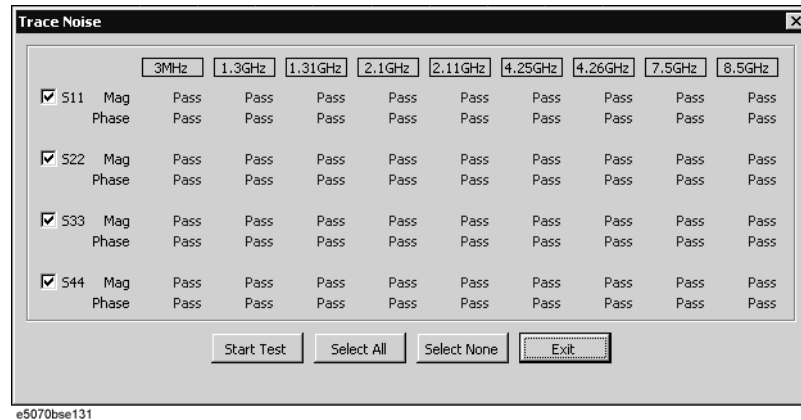

- f. If at least one of the Trace Noise tests failed, refer to Table 4-20 External Test Failure Troubleshooting Information.
- g. To return to the External Test dialog box, click "Exit" button.

[6] Error Term tests

These tests check the reflection tracking, directivity and source match for all test ports.

Required equipment:

Description	Recommended model
Calibration kit (type-N Open, Short and 50Ω Load terminations)	85032F

Procedure:

Perform the following procedure after Step 11.

- a. Click "Test" button in the right of "Error Term" in the window to open the "Error Term" window. The window displays the port number and frequencies as the test points. The result for each test port is displayed as the 4x3 matrix.(Figure 4-75).

Figure 4-75 Error Term (port 1) tests dialog box example (E5071A)

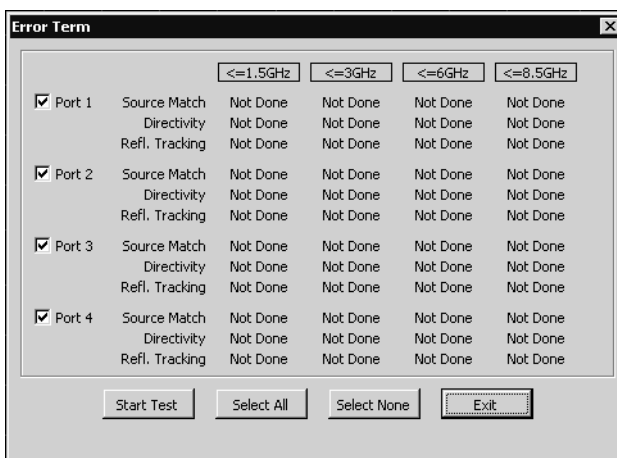

e5070bse133

- b. Select the test ports for the test by clicking the check boxes. Then, click “Start Test” button. The instruction dialog box opens as shown in Figure 4-76. Follow the instruction.

NOTE

Clicking “Select All” button checks all the check boxes. Clicking "Select None" button clears all the check boxes. Click "Exit" to return to the External Test dialog box

Figure 4-76 OPEN (port 1) dialog box

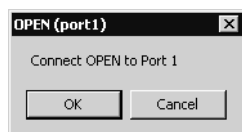

e5070bse132

- c. Connect an type-N Open termination to the specified port.

NOTE

For more information on Error Term tests setup, see Table 4-19.

Table 4-19 Error Term tests setup

Test parameter	Connect	Sweep freq span, IFBW, Nop and RF power settings, System correction (Automatic)
Source match	Open	Full span, 1 kHz BW, 201, -5 dBm , System correction OFF
Directivity	Short	
Reflection tracking	Load	

- d. Click "OK" button to continue the test. The "Error Term" dialog box displays "Now calibrating..." for a few seconds. Wait until "SHORT" dialog box opens.
- e. Connect an type-N Short termination to the specified test port.
- f. Click "OK" button to continue the test and wait until "LOAD" dialog box opens.

- g. Connect a 50 Ω Load termination to the specified test port.
- h. Click "OK" button to continue the test and wait for a few seconds.
- i. Repeat step form c to h for all of the selected test ports.
- j. When the tests are completed, the "Error Term" dialog box displays Pass or Fail for each test as shown in Figure 4-77.

Figure 4-77 Error Term test results example (E5071A)

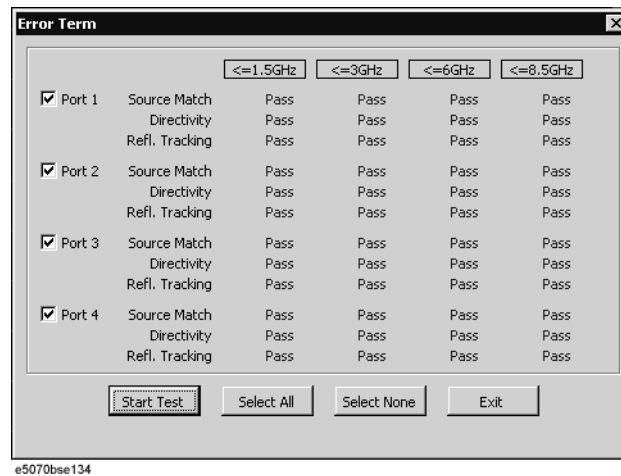

- k. If at least one of the Error Term tests failed, refer to Table 4-20 External Test Failure Troubleshooting Information.
- l. To return to the External Test dialog box, click "Exit" button.

[7] Handler I/O Board tests

These tests check the function of Handler I/O board for interfacing with an external component handler. The tests are performed using a handler I/O test kit as a substitute for the handler.

Required equipment:

Description	Recommended model
Handler I/O test kit	E5070-65001

Procedure:

- Perform the following procedure after Step 11.
- a. Click "Handler I/O Board" in the pull down menu of the Test List box.
- b. Click "Test" button in the dialog box. Then "Handler I/O Board" tests dialog box opens as shown in Figure 4-78.

Figure 4-78 Handler I/O Board tests dialog box

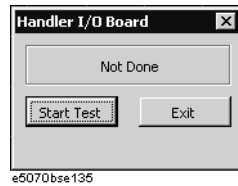

- c. Click the "Test" button in the dialog box. A message of "Connect Handler I/O Test Kit" will be displayed.
- d. Connect the handler I/O test kit to the Handler I/O connector on the rear panel.
- e. Click "OK" button. The dialog box displays "Now testing..." while the Handler I/O Board test is in progress.
- f. When the tests are completed, the dialog box displays Pass or Fail of test result as shown in Figure 4-79.

Figure 4-79 Handler I/O Board test result example

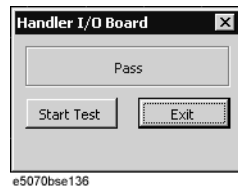

- g. If the Handler I/O Board test failed, refer to Table 4-20 External Test Failure Troubleshooting Information.
- h. To return to the External Test dialog box, click "Exit" button.

NOTE

To end the external test, click "Exit" button in the "External Test" dialog box.

External Test Failure Troubleshooting

Table 4-20 represents the contents of the external tests, test objectives and the relationships of failed tests to probable faulty board assemblies. If the instrument fails an external test,

replace the faulty board assembly as shown in Table 4-20.

Table 4-20 External test failure troubleshooting information

Test No.	Test group	First failed test	Test objective	Probable faulty board assembly				
				A1 Source	A6 Sw/T cont	A2 Receiver		A23 Hnd
						A14	A17	
1	Power Gain (A1 and A2)	S12(50MHz)	Source power for Port 2 and receiver gain for Port 1	##		##	##	
2		S12(3GHz)	Source power for Port 2 and receiver gain for Port 1	##		##	##	
3		S12(6GHz)	Source power for Port 2 and receiver gain for Port 1 (E5071A)	##		##	##	
4		S21(50MHz)	Source power for Port 1 and receiver gain for Port 2	##		##	##	
5		S21(3GHz)	Source power for Port 1 and receiver gain for Port 2	##		##	##	
6		S21 (6GHz)	Source power for Port 1 and receiver gain for Port 2 (E5071A)	##		##	##	

Table 4-20 External test failure troubleshooting information

Test No.	Test group	First failed test	Test objective	Probable faulty board assembly				
				A1 Source	A6 Sw/T cont	A2 Receiver		A23 Hnd
						A14	A17	
7		S31(50MHz)	Source power for Port 1 and receiver gain for Port 3 (Opt. 313/314/413/414)	##		##	##	
8		S31(3GHz)	Source power for Port 1 and receiver gain for Port 3 (Opt. 313/314/413/414)	##		##	##	
9		S31(6GHz)	Source power for Port 1 and receiver gain for Port 3 (E5071A Opt. 313/314/413/414)	##		##	##	
10		S41(50MHz)	Source power for Port 1 and receiver gain for port 4 (Opt. 413/414)	##		##	##	
11		S41(3GHz)	Source power for Port 1 and receiver gain for port 4 (Opt. 413/414)	##		##	##	
12		S41(6GHz)	Source power for Port 1 and receiver gain for Port 4 (E5071A Opt. 413/414)	##		##	##	

Table 4-20 External test failure troubleshooting information

Test No.	Test group	First failed test	Test objective	Probable faulty board assembly				
				A1 Source	A6 Sw/T cont	A2 Receiver		A23 Hnd
						A14	A17	
13	Tch IF Ranging(A2)	S12(T1, Mag) S12(T1, Phase) S21(R1, Mag) S21(R1, Phase)	IF signal level ranging operation of receiver for Port 1	#		#	###	
14		S21(T2, Mag) S21(T2, Phase) S12(R2, Mag) S12(R2, Phase)	IF signal level ranging operation of receiver for Port 2	#		#	###	
15		S31(T3, Mag) S31(T3, Phase) S13(R3, Mag) S13(R3, Phase)	IF signal level ranging operation of receiver for Port 3 (Opt. 313/314/413/414)	#		#	###	
16		S41(T4, Mag) S41(T4, Phase) S14(R4, Mag) S14(R4, Phase)	IF signal level ranging operation of receiver for Port 4 (Opt. 413/414)	#		#	###	
17	Receiver Linearity	S12(Mag.) S12(Phase)	Receiver gain linearity for Port 1	#		###	#	
18		S21(Mag.) S21(Phase)	Receiver gain linearity for Port 2	#		###	#	
19		S31(Mag.) S31(Phase)	Receiver gain linearity for Port 3 (Opt. 313/314/413/414)	#		###	#	
20		S41(Mag.) S41(Phase)	Receiver gain linearity for Port 4 (Opt. 413/414)	#		###	#	
21	Dynamic Range	S12, S13, S14, S21, S23, S31, S32, S34 (Opt. 313/314/413/414), S41, S43 (Opt. 413/414)	Dynamic range for all test ports	##		##	#	

4. Troubleshooting

Troubleshooting
Troubleshooting Using External Test

Table 4-20 External test failure troubleshooting information

Test No.	Test group	First failed test	Test objective	Probable faulty board assembly				
				A1 Source	A6 Sw/T cont	A2 Receiver		A23 Hnd
						A14	A17	
22	Trace Noise (port 1)	S11(Mag./Phase)	Trace noise for Port 1	###		##	##	
23	Trace Noise (port 2)	S22(Mag./Phase)	Trace noise for Port 2	###		##	##	
24	Trace Noise (port 3)	S33(Mag./Phase)	Trace noise for Port 3 (Opt. 313/314/413/414)	###		##	##	
25	Trace Noise (port 4)	S44(Mag./Phase)	Trace noise for Port 4 (Opt. 413/414)	###		##	##	
26	Error Term (port 1)	-	Source match, directivity and reflection tracking for Port 1	#		###		
27	Error Term (port 2)	-	Source match, directivity and reflection tracking for Port 2	#		###		
28	Error Term (port 3)	-	Source match, directivity and reflection tracking for Port 3 (Opt. 313/314/413/414)	#		###		
29	Error Term (port 4)	-	Source match, directivity and reflection tracking for Port 4 (Opt. 413/414)	#		###		
30	Handler I/O Board	-	Handler interface I/O signals					###

###: Most suspicious assembly

##: Suspicious assembly

#: Possible faulty assembly

NOTE When the external test for a specific receiver port fails, identify the faulty A2 receiver board as shown in Figure 4-80.

Figure 4-80 Test port configuration

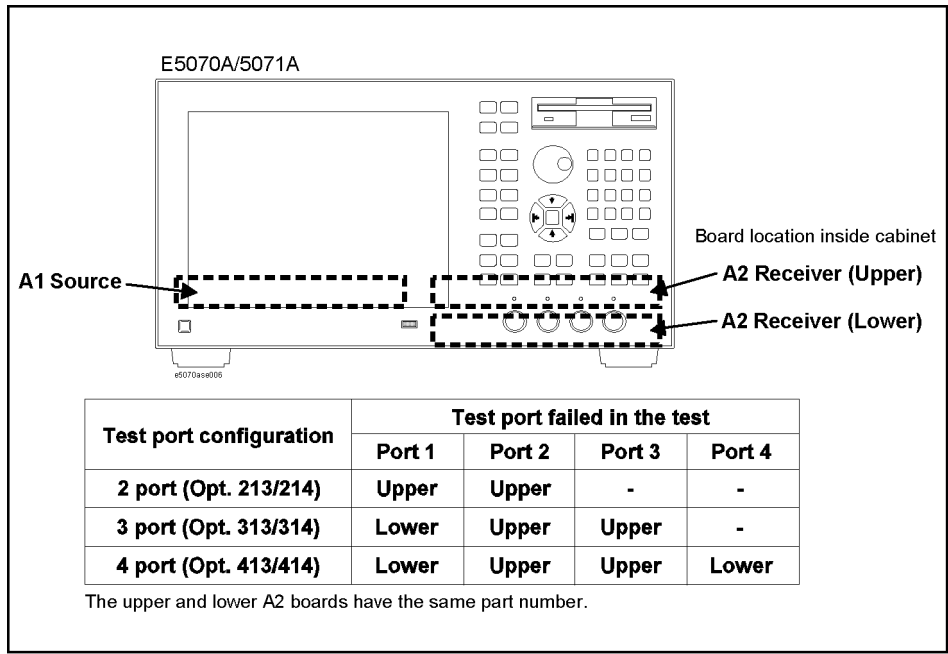

e5070ase282

Performance test failure troubleshooting

This section describes the adjustment and troubleshooting procedures used when the E5070A/E5071A fails the performance tests. If the performance of the instrument is critical for the test limits and seems to be adjustable, perform first the adjustment(s) related to the failed test. When the test result is distant from the tolerance of the test or the performance is not adjustable, isolate the faulty assembly in accordance with the "Performance tests failure troubleshooting procedure".

Recommended adjustment for performance test failure

Table 4-21 shows the recommended adjustments when the performance test fails. Select the adjustment program corresponding to the recommended adjustment and perform the adjustment.

NOTE There are no adjustment related to the crosstalk, system dynamic range and uncorrected system performance.

Table 4-21 Recommended adjustment for performance test failure

Test Num.	First failed test	Recommended adjustment			
		X'tal oven (A5)	Source (A1)	Receiver RF (A14)	Receiver IF (A17)
1	Frequency accuracy test (Standard)		√		
1A	Frequency accuracy test (Opt. 1E5 only)	√			
2	RF output level accuracy and flatness test		√		
3	RF output level linearity test		√		
4	Trace noise CW test				√
5	Crosstalk test				
6	System dynamic range test				
7	Dynamic accuracy test				√
8	Uncorrected system performance test				

Performance test failure troubleshooting

Table 4-22 represents the relationships between the failed test and probable faulty assembly. If the performance test failure cannot be removed by a proper adjustment, replace the assembly shown in this table.

Note that this table lists some typical cases. There are possibilities that other assembly may be faulty. To troubleshoot in further details, perform the internal test and external test procedures

NOTE When Crosstalk, System dynamic range or Uncorrected system performance test fails, check first whether the connections of the RF semi-rigid cables between the suspicious assembly and others are tight or loose. Also check for possible disconnection (impairment) of the cables and connectors.

Table 4-22 Performance test failure troubleshooting information

Test Num	First failed test	Probable faulty board assembly				
		A1 Source	A5 Xtl Oven	A2 Receiver		A8 Src Switch
				A14	A17	
1	Frequency accuracy test (Standard)	###				
1A	Frequency accuracy test (Opt. 1E5 only)	##	###			
2	RF output level accuracy and flatness test	###				
3	RF output level linearity test	###				
4	Trace noise CW test	###		##	##	
5	Crosstalk test	#		##	#	###
6	System dynamic range test	##		##	#	###
7	Dynamic accuracy test			###	##	
8	Uncorrected system performance test	#		##	#	###

###: Most suspicious assembly

##: Suspicious assembly

#: Possible faulty assembly

To configure the A20 Digital Motherboard and BIOS

When you replace the A20 digital motherboard, you need to confirm the jumper settings for the specific CPU installed. The jumper settings information is provided in “Configure the Motherboard” on page 216.

You also need to confirm the BIOS options using the BIOS setup utility procedure. Since the BIOS detects the A27 mass storage and displays the profile of the disk drive, it is a useful tool to verify whether the A27 has a problem or not. The BIOS setup procedure is described in “To Confirm or Set the BIOS Options” on page 218.

To Identify the Motherboard Installed

The A20 digital motherboard of the E5070A/E5071A is equipped with Intel Pentium® III - 700 MHz or 850 MHz processor. During the RAM counting after power on, the "Pentium® III, 700 MHz" or "Pentium® III, 850 MHz" is displayed as shown in Figure 4-7.

Configure the Motherboard

There are several jumpers on the A20 digital motherboard that must be configured to the correct settings for the Pentium® III - 700 MHz or 850 MHz processor. Confirm the jumper settings and set the jumpers correctly as shown in Figure 4-81.

Figure 4-81 A20 digital motherboard jumpers location and settings

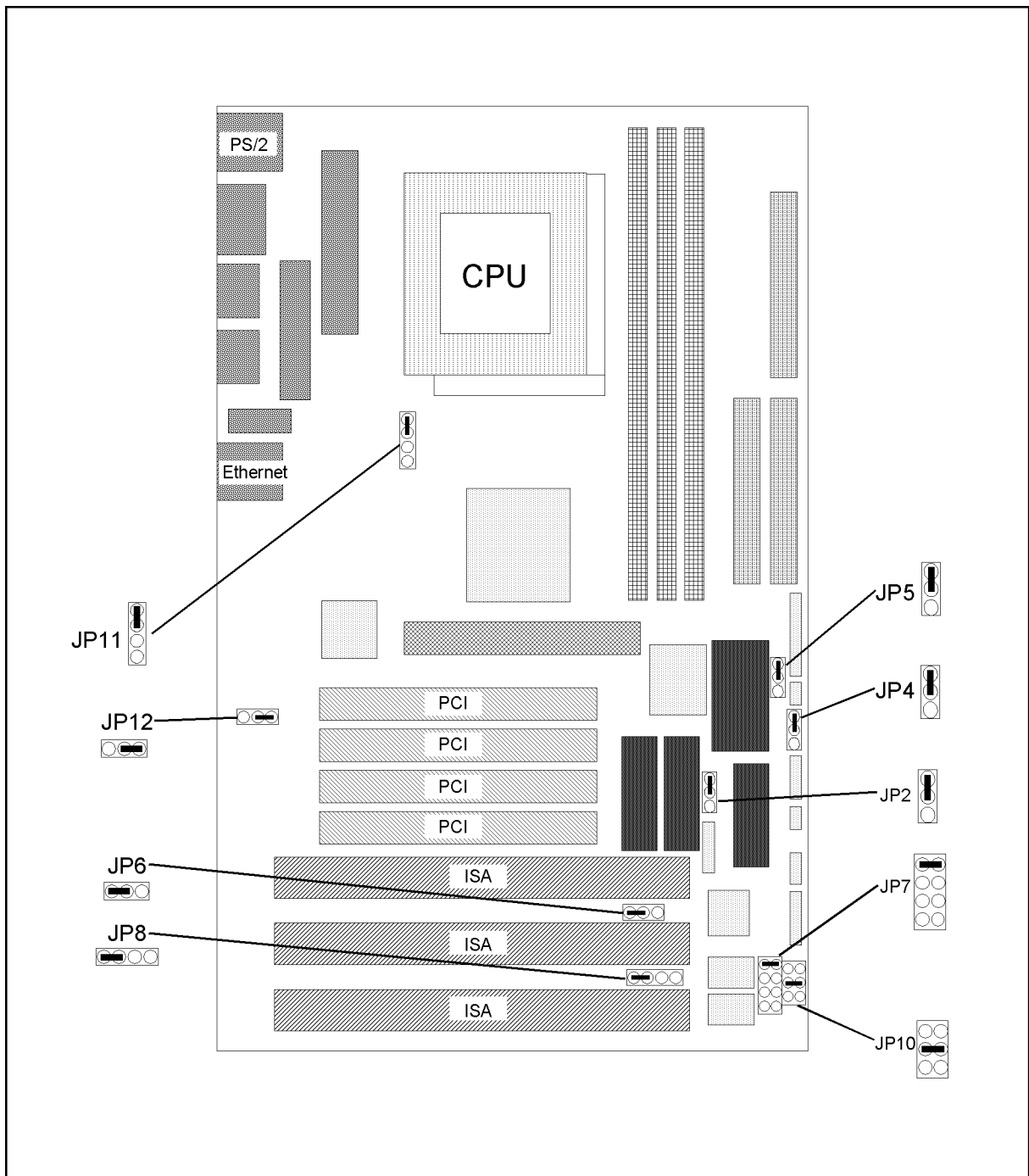

e5070ase158

NOTE

If the following jumper settings are not correct, they cause particular problems as described below. Be sure to set these jumpers to the correct positions.

JP4: Power-on failure.

JP5: Some setup data in memory may be lost.

JP11: Digital-processing speed changes due to improper BUS clock setting.

JP12: LAN (Ethernet) interface is disabled.

Testing DRAM on the Motherboard

When the A20 digital motherboard is replaced with a new one, it is recommended to perform the DRAM test before proceeding to the BIOS setup utility procedure. Confirm the DRAM count in accordance with the following procedure.

- Step 1.** Connect the external keyboard and mouse to the E5070A/E5071A rear panel connectors.
- Step 2.** Turn the instrument on. Wait until the E5070A/E5071A boots up. Do not press any key until the E5070A/E5071A measurement view appears.
- Step 3.** Press key on the front panel.
- Step 4.** Click **Explore...** in the softkey menu.
- Step 5.** Click "Control Panel" icon in the "My Computer" configuration menu.
- Step 6.** Scroll the function viewer to find "System" icon and double-click "System". This opens "System Properties" window as shown in Figure 4-82.

Figure 4-82

System Properties window



- Step 7.** Verify that "384.0MB RAM" is displayed in the Computer profile as shown in Figure 4-82. If it is not correct, the A20 board is faulty.
- Step 8.** Click "OK" button to close the window.
- Step 9.** Turn the E5070A/E5071A off before proceeding to the next "To Confirm or Set the BIOS Options".

To Confirm or Set the BIOS Options

BIOS is the PC's built-in program describing the standard procedure of basic inputs and outputs for the system hardware. BIOS involves the system BIOS, start-up program and

To configure the A20 Digital Motherboard and BIOS

BIOS setup utility. The E5070A/E5071A starts up first with the BIOS when the power is turned on. Use the following procedure to confirm or set the BIOS options, known as the BIOS setup utility.

Run the BIOS setup utility

Use the external keyboard to select and set various options in the BIOS setup utility. Do not operate the E5070A/E5071A front panel until you exit the BIOS option setup procedure.







- Procedure**
- Step 1.** Connect the external keyboard to the E5070A/E5071A rear panel connector.
 - Step 2.** Turn the instrument on.
 - Step 3.** Press  key as soon as the message of "Hit DEL if you want to run SETUP" is displayed. Wait a few seconds until a message of "Enter CURRENT Password:" appears.
 - Step 4.** Press  key (The LED in the key lights.)
 - Step 5.** Enter password "e507xa" and press . Then BIOS setup utility main menu is displayed as shown in Figure 4-83.

Figure 4-83

BIOS setup utility main menu

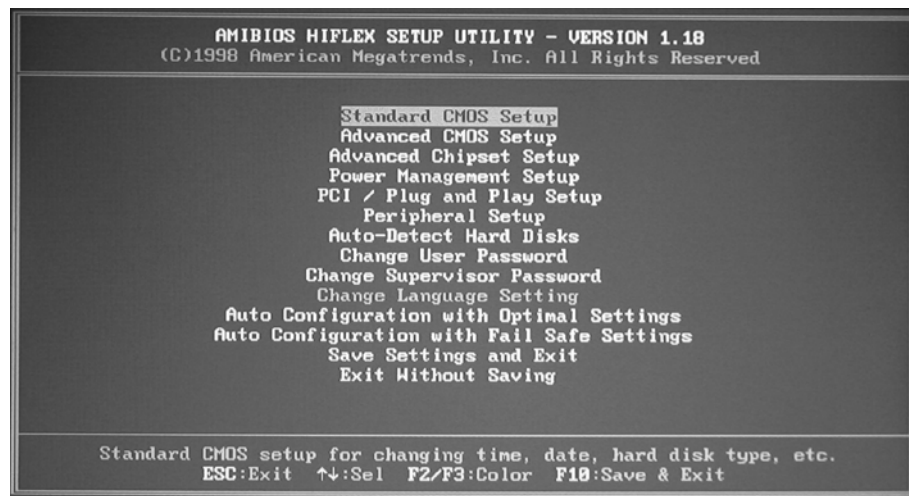
- Step 6.** The BIOS setup utility has 11 selectable windows. Brief descriptions and reference pages for these windows are provided in Table 4-23. The details of the BIOS option settings in each window are described on the page listed in the table.
- Step 7.** Select a desired window using  and  keys or  key. To perform an operation, use  key.

NOTE

If you want to quit the BIOS option setting and exit the BIOS setup utility without saving

changes in the setup, select "Exit Without Saving" and press **Enter**.

Table 4-23 BIOS setup utility windows and references

Window name	Contents of setup utility	Ref. page
Standard CMOS Setup	The default settings of all the Standard CMOS Setup options. The procedure to set date or time is also described.	on page 221
Advanced CMOS Setup	The default settings of all the advanced CMOS Setup options	on page 222
Advanced Chipset Setting	The default settings of all the Advanced Chipset Setting options	on page 224
Power Management Setup	The default settings of all the Power Management Setup options	on page 226
PCI/Plug and Play Setup	The default settings of all the PCI/Plug and Play Setup options	on page 227
Peripheral Setup	The default settings of all the Peripheral Setup options	on page 229
Auto-Detect Hard Drive	The methods to verify whether or not the system detected the mass storage and configured correctly the mass storage drive parameters.	on page 231
Change User Password	None (This option is unnecessary for the E5070A/E5071A.)	
Change Supervisor Password	The method to assign a password (This option is used only when the password has not been set in the E5070A/E5071A.)	on page 231
Auto Configuration with Optimal Settings	The procedure to initialize BIOS option settings (This option is used only when the A20 digital motherboard is replaced with a new one.)	on page 221
Auto Configuration with Fail Safe Settings	None (This option is unnecessary for the E5070A/E5071A.)	
Save Settings and Exit	The procedure to save the option settings and exit from BIOS setup utility.	on page 232
Exit Without Saving	The procedure to exit from BIOS setup utility without saving the option settings.	on page 232

NOTE The "Change Language Setting" window (displayed in gray characters) is invalid and cannot be selected.

Auto Configuration with Optimal Settings

NOTE

Perform the following procedure only when the A20 digital motherboard is replaced. Jump to "Standard CMOS Setup" when you check whether the BIOS options are correctly set or not.

Auto configuration dialog box is displayed by choosing "Auto Configuration with Optimal Settings" using and keys and by pressing key at the BIOS Setup Utility main menu. The dialog box prompts you to select Y (Yes) or N (No) about "Load high performance settings (Y/N) ?" as shown in Figure 4-84. Press and to load the high performance settings. As a result, all the BIOS options are automatically configured to the optimal settings for the E5070A/E5071A.

Figure 4-84

High performance setting dialog box

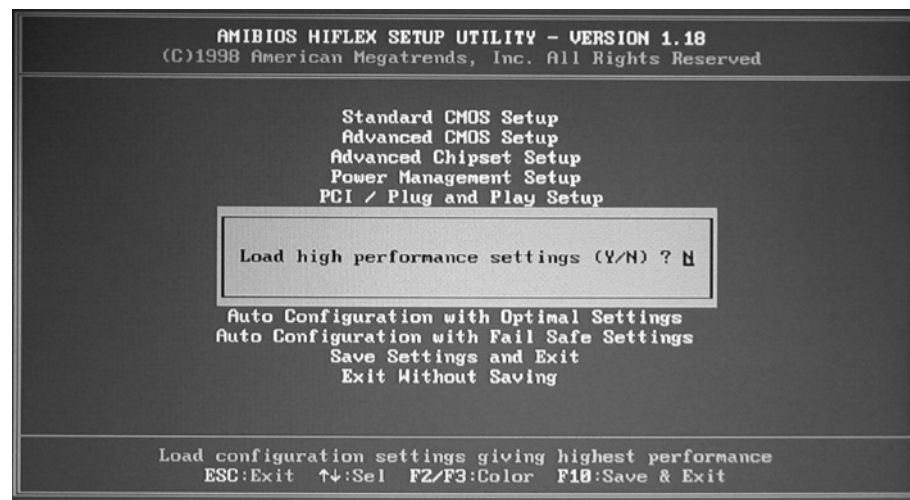

Standard CMOS Setup

Standard CMOS Setup options are displayed by choosing "Standard CMOS Setup" using and keys and by pressing key at the BIOS Setup Utility main menu. The current setup states are displayed as shown in Figure 4-85. If date or time is incorrect, select it using and keys, and change the setting by pressing and keys.

If you want to exit from this page and return to main menu, press key.

Figure 4-85 Standard CMOS Setup window

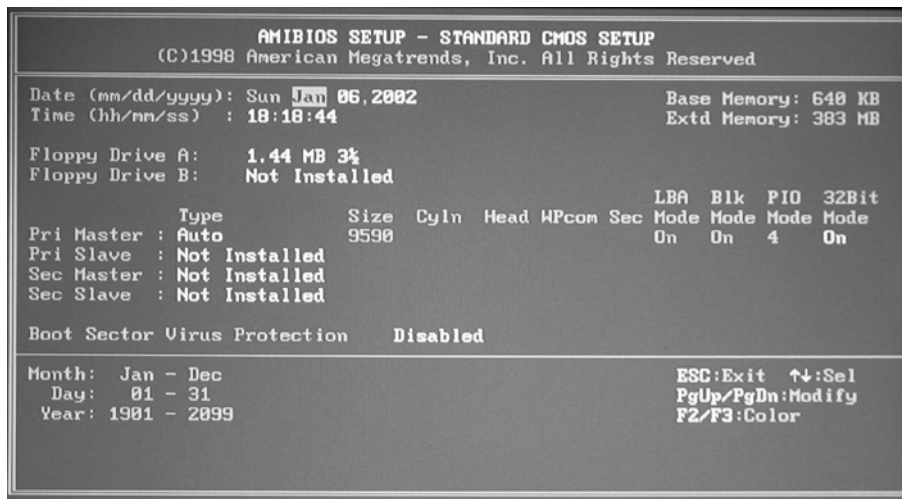

Advanced CMOS Setup

Advanced CMOS Setup options are displayed by choosing "Advanced CMOS Setup" using **↑** and **↓** keys and by pressing **Enter** key at the BIOS Setup Utility main menu. Then the window as shown in Figure 4-86 appears. Compare the actual BIOS option settings with the default settings shown in Table 4-24. If there is any difference, select it using **↑** and **↓** keys, and change the option setting by pressing **Page Up** and **Page Down** keys so that it becomes the same as the default setting.

If you want to exit from this page and return to main menu, press **Esc** key.

Figure 4-86 Advanced CMOS Setup window

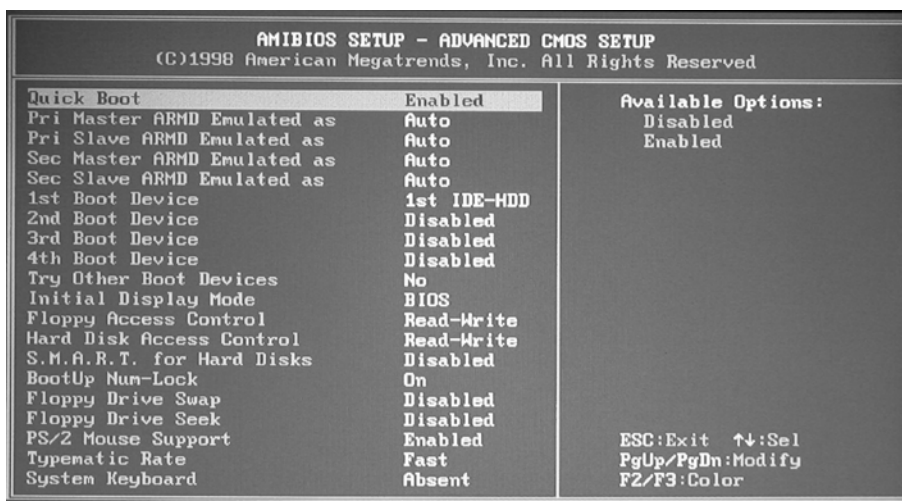

Table 4-24

Quick Boot	Enabled
Pri Master ARMD Emulated as	Auto

Table 4-24

Pri Slave ARMD Emulated as	Auto
Sec Master ARMD Emulated as	Auto
Sec Slave ARMD Emulated as	Auto
1st Boot Devices	1st IDE-HDD
2nd Boot Devices	Disabled
3rd Boot Devices	Disabled
4th Boot Devices	Disabled
Try Other Boot Devices	No
Initial Display Mode	BIOS
Floppy Access Control	Read-Write
Hard Disk Access Control	Read-Write
S.M.A.R.T. for Hard Disks	Disabled
Boot Up Num-Lock	On
Floppy Drive Swap	Disabled
Floppy Drive Seek	Disabled
PS/2 Mouse Support	Enabled
Typematic Rate	Fast
System Keyboard	Absent
Primary Display	VGA/EGA
Password Check	Setup
Boot To OS/2	No
Wait For 'F1' If Error	Enabled
Hit 'Del' Message Display	Enabled
Internal Cache	WriteBack
System BIOS Cacheable	Enabled
C000,16k shadow	Enabled
C400,16k shadow	Enabled
C800,16k shadow	Disabled
CC00,16k shadow	Disabled
D000,16k shadow	Disabled
D400,16k shadow	Disabled

Table 4-24

D800,16k shadow	Disabled
DC00,16k shadow	Disabled

Advanced Chipset Setup

Advanced Chipset Setup options are displayed by choosing "Advanced Chipset Setup" using **[↑]** and **[↓]** keys and by pressing **[Enter]** key at the BIOS Setup Utility main menu. Then the window as shown in Figure 4-87 appears. Compare the actual BIOS option settings with the default settings shown in Table 4-25. If there is any difference, select it using **[↑]** and **[↓]** keys, and change the option setting by pressing **[Page Up]** and **[Page Down]** keys so that it becomes the same as the default setting.

If you want to exit from this page and return to main menu, press **[Esc]** key.

Figure 4-87

Advanced Chipset Setup window

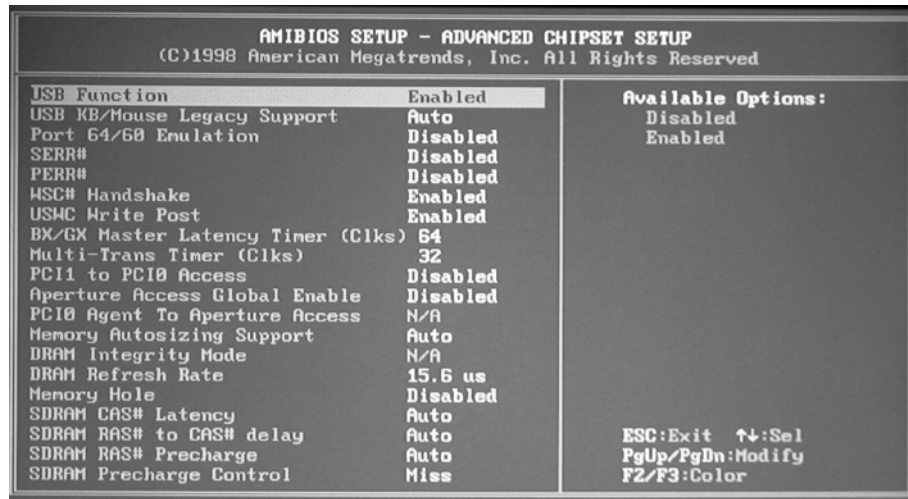

Table 4-25

USB Function	Enabled
USB KB/Mouse Legacy Support	Auto
Port 64/60 Emulation	Disabled
SERR#	Disabled
PERR#	Disabled
WSC# Handshake	Enabled
USWC Write Post	Enabled
BX/GX Master Latency Timer (Clks)	64
Multi-Trans Timer (Clks)	32
PCI1 to PCI0 Access	Disabled

Table 4-25

Aperture Access Global Enable	Disabled
PCI0 Agent To Aperture Access	N/A
Memory Autosizing Support	Auto
DRAM Integrity Mode	N/A
DRAM Refresh Rate	15.6 us
Memory Hole	Disabled
SDRAM CAS# Latency	Auto
SDRAM RAS# to CAS# delay	Auto
SDRAM RAS# Precharge	Auto
SDRAM Precharge Control	Miss
Power Down SDRAM	Disabled
ACPI Control Register	Disabled
Gated Clock	Enabled
Graphics Aperture Size	64MB
Search for MDA Resources	Yes
AGP Read Sync	Disabled
AGP Snoopable Write	Enabled
AGP Mlti-Trans Timer (AGP Clks)	32
AGP Low-Priority Timer (AGP Clks)	16
AGP SERR	Disabled
AGP Parity Error Response	Disabled
8bit I/O Recovery Time	Disabled
16bit I/O Recovery Time	Disabled
PIIX4 SERR#	Disabled
USB Passive Release	Enabled
PIIX4 Passive Release	Enabled
PIIX4 Delayed Transaction	Enabled
TypeF DMA Buffer Control1	Disabled
TypeF DMA Buffer Control2	Disabled
DMA-0 Type	Normal ISA
DMA-1 Type	Normal ISA

Table 4-25

DMA-2 Type	Normal ISA
DMA-3 Type	Normal ISA
DMA-5 Type	Normal ISA
DMA-6 Type	Normal ISA
DMA-7 Type	Normal ISA
Memory Buffer Strength	Strong
Manufacture Setting	Mode 0

Power Management Setup

Power Management Setup options are displayed by choosing "Power Management Setup" using **↑** and **↓** keys and by pressing **Enter** key at the BIOS Setup Utility main menu. Then the window as shown in Figure 4-88 appears. Compare the actual BIOS option settings with the default settings shown in Table 4-26. If there is any difference, select it using **↑** and **↓** keys, and change the option setting by pressing **Page Up** and **Page Down** keys so that it becomes the same as the default setting.

If you want to exit from this page and return to main menu, press **Esc** key.

Figure 4-88

Power Management Setup window

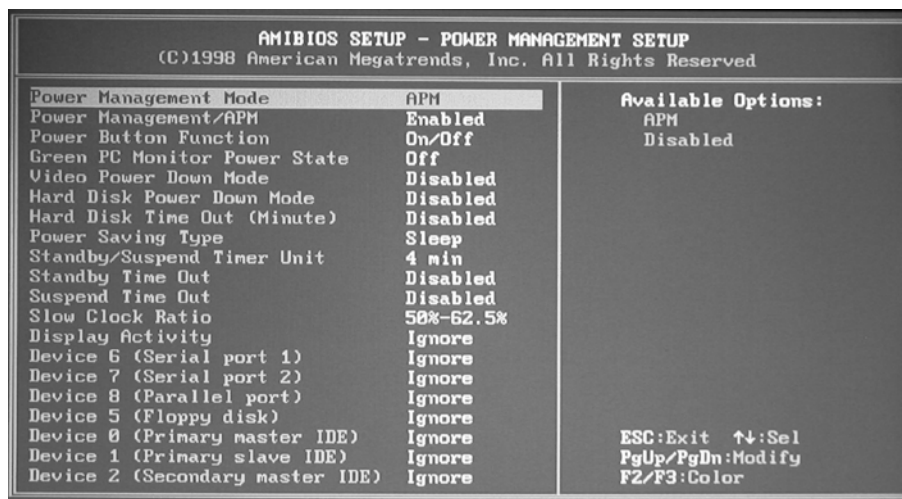









Table 4-26

Power Management Mode	APM
Power Management/APM	Enabled
Power Button Function	On/Off
Green PC monitor Power State	Off
Video Power Down Mode	Disabled

Table 4-26

Hard Disk Power Down Mode	Disabled
Hard Disk Time Out (Minute)	Disabled
Power Saving Type	Sleep
Standby/Suspend Timer Unit	4 min
Standby Time Out	Disabled
Suspend Time Out	Disabled
Slow Clock Ratio	50-62.5%
Display Activity	Ignore
Device 6 (Serial port 1)	Ignore
Device 7 (Serial port 2)	Ignore
Device 8 (Parallel port)	Ignore
Device 5 (Floppy Disk)	Ignore
Device 0 (Primary master IDE)	Ignore
Device 1 (Primary slave IDE)	Ignore
Device 2 (Secondary master IDE)	Ignore
Device 3 (Secondary slave IDE)	Ignore
LAN Wake-Up	Disabled

PCI/Plug and Play Setup

PCI/Plug and Play Setup options are displayed by choosing "PCI/Plug and Play Setup" using  and  keys and by pressing  key at the BIOS Setup Utility main menu. Then the window as shown in Figure 4-89 appears. Compare the actual BIOS option settings with the default settings shown in Table 4-27. If there is any difference, select it using  and  keys, and change the option setting by pressing  and  keys so that it becomes the same as the default setting.

If you want to exit from this page and return to main menu, press  key.

Figure 4-89

PCI/Plug and Play Setup window

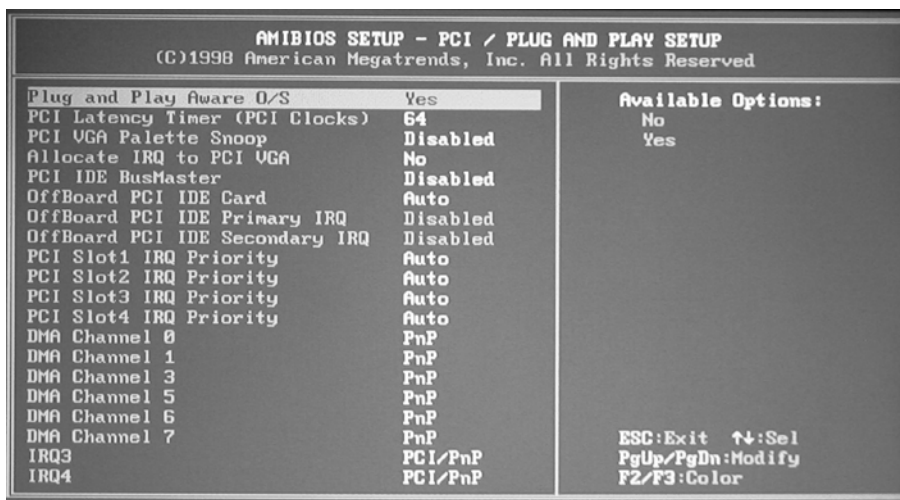









Table 4-27

Plag and Play Aware O/S	Yes
PCI Latency Timer (PCI Clocks)	64
PCI VGA Palette Snoop	Disabled
Allocate IRQ to PCI VGA	No
PCI IDE BusMaster	Disabled
OffBoard PCI IDE Card	Auto
OffBoard PCI IDE Primary IRQ	Disabled
OffBoard PCI IDE Secondary IRQ	Disabled
PCI Slot1 IRQ Priority	Auto
PCI Slot2 IRQ Priority	Auto
PCI Slot3 IRQ Priority	Auto
PCI Slot4 IRQ Priority	Auto
DMA Channel 0	PnP
DMA Channel 1	PnP
DMA Channel 3	PnP
DMA Channel 5	PnP
DMA Channel 6	PnP
DMA Channel 7	PnP
IRQ3	PCI/PnP
IRQ4	PCI/PnP

Table 4-27

IRQ5	PCI/PnP
IRQ7	PCI/PnP
IRQ9	ISA/EISA
IRQ10	PCI/PnP
IRQ11	PCI/PnP
IRQ12	ISA/EISA
IRQ14	PCI/PnP
IRQ15	PCI/PnP
Reserved Memory Size	Disabled
Reserved Memory Address	C8000
PCI Device Search Order	First-Last
Default Primary Video	AGP

Peripheral Setup

Peripheral Setup options are displayed by choosing "Peripheral Setup" using  and  keys and by pressing  key at the BIOS Setup Utility main menu. Then the window as shown in Figure 4-90 appears. Compare the actual BIOS option settings with the default settings shown in Table 4-28. If there is any difference, select it using  and  keys, and change the option setting by pressing  and  keys so that it becomes the same as the default setting.

If you want to exit from this page and return to main menu, press  key.

Figure 4-90

Peripheral Setup window

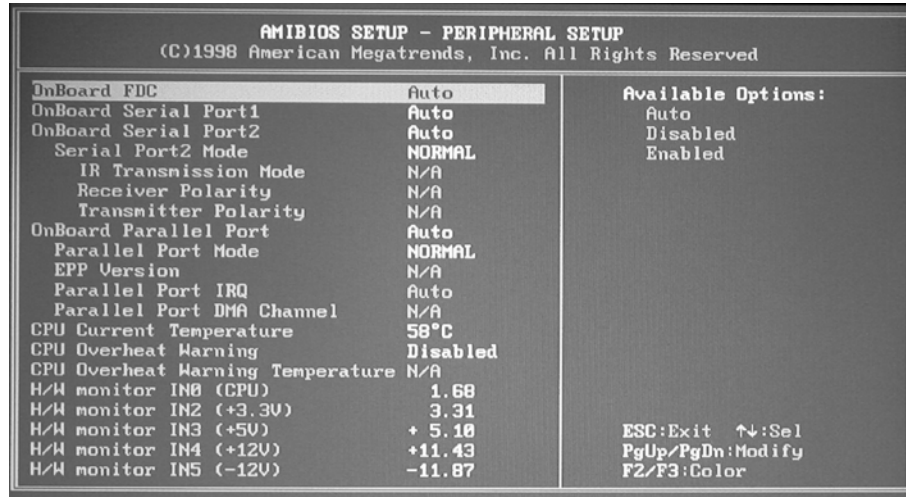

Table 4-28

OnBoard FDC	Auto
OnBoard Serial Port1	Auto
OnBoard Serial Port2	Auto
Serial Port2 Mode	Normal
IR Transmission Mode	N/A
Receiver Polarity	N/A
Transmitter Polarity	N/A
OnBoard Parallel Port	Auto
Parallel Port Mode	Normal
EPP Version	N/A
Parallel Port IRQ	Auto
Parallel Port DMA Channel	N/A
CPU Current Temperature	(a temperature displays)
CPU Overheat Warning Temperature	N/A
H/W monitor IN0(CPU)	(a voltage displays)
H/W monitor IN2(+3.3V)	(a voltage displays)
H/W monitor IN3(+5V)	(a voltage displays)
H/W monitor IN4(+12V)	(a voltage displays)
H/W monitor IN5(-12V)	(a voltage displays)
H/W monitor IN6(-5V)	(a voltage displays)

Table 4-28

CPU Fan	(a number of revolutions displays)
Secondary Fan	N/A
OnBoard IDE	Both

Auto-Detect Hard Disks

Auto-Detect Hard Disks options are displayed by choosing "Auto-Detect Hard Disks" using **↑** and **↓** keys and by pressing **Enter** key at the BIOS Setup Utility main menu. Compare the actual BIOS option settings with the default settings shown in Figure 4-91 (The display is similar to Standard CMOS Setup window).

The profile of the A27 mass storage (hard disk) connected to the primary channel IDE of the A20 digital motherboard is indicated in the Pri Master drive data. When a problem seems around the mass storage, verify whether or not the E5070A/E5071A system detects the mass storage correctly using this BIOS option.

If you want to exit from this page and return to main menu, press **Esc** key.

Figure 4-91

Auto-Detect Hard Disks window

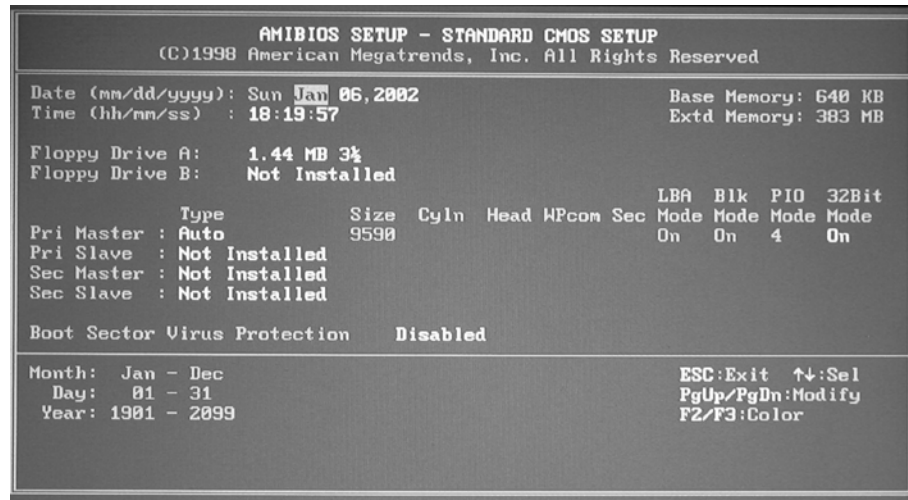

Change Supervisor Password

A password needs to be entered to execute the BIOS setup utility. If a password has not been assigned in the E5070A/E5071A, set the password using this BIOS setup utility as follows.

- a. Select "Change Supervisor Password" using **↑** and **↓** keys at the BIOS Setup Utility main menu and press **Enter** key.
- b. Enter the password of "e507xa". Never set another password.
- c. Press **Enter** key.
- d. If a message of "New supervisor password installed. Press any key to continue" is

displayed, press key.

Save Settings and Exit

When you want to change and save a BIOS option, Select "Save Settings and Exit" using and keys at the BIOS Setup Utility main menu and press key. Then, a message of "Save current settings and exit (Y/N)?" is displayed. Press and keys.

The BIOS setup utility is closed after the current settings are saved.

Exit Without Saving

If you cancel the changes in the BIOS option settings, select "Exit Without Saving" using and keys at the BIOS Setup Utility main menu and press key. Then, a message of "Quit without saving (Y/N)?" is displayed. Press and keys.

The BIOS setup utility is closed without saving the current settings.

5 **Replaceable Parts**

This chapter contains information for ordering replacement parts for the E5070A/E5071A ENA Series RF Network Analyzers.

Ordering Information

To order part listed in the replaceable part lists, quote the Agilent part number (with a check digit), indicate the quantity required, and address the order to the nearest Agilent office. The check digit will ensure accurate and timely processing of the order.

To order a part not listed in the replaceable part table, include the instrument model number, the description and function of the part, and the quantity of parts required. Address the order to the nearest Agilent office.

Direct Mail Order System

Within the USA, Agilent can supply parts through a direct mail order system. There are several advantages to this system:

- Direct ordering and shipping from the Agilent Parts Center in Mountain View, California.
- No maximum or minimum on any mail order (there is a minimum order amount for parts ordered through a local Agilent office when the orders require billing and invoicing)
- Prepaid transportation (there is a small handling charge for each order).
- No invoices.

In order for Agilent to provide these advantages, please send a check or money order with each order.

Mail order forms and specific ordering information are available through your local Agilent sales office. Addresses and telephone numbers are located in a separate document shipped with the manuals.

Exchange Assemblies

Under the rebuilt-exchange assembly program, certain factory-repaired and tested assemblies are available on a trade-in basis. These assemblies are offered at lower cost than a new assembly, but meet all factory specifications required of a new assembly.







The defective assembly must be returned for credit under the terms of the rebuilt-exchange assembly program. Any spare assembly stock desired should be ordered using the new assembly part number.

Replaceable Parts List

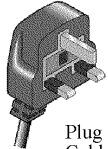
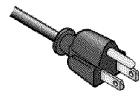
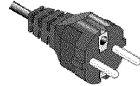
Power Cables and Plug Configurations

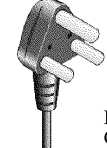
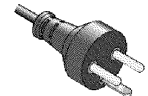
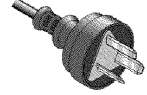
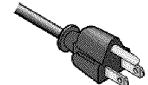
Figure 5-1

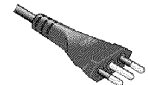
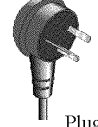
Power Cables and Plug Configurations

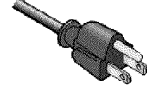
OPTION 900  United Kingdom Plug : BS 1363/A, 250V, 10A Cable: 8120-1351	OPTION 903  U.S./ Canada Plug : NEMA 5-15P, 125V, 10A Cable: 8120-1378
OPTION 902  Continental Europe Plug : CEE 7 Standard Sheet VII, 250V, 10A Cable: 8120-1689	OPTION 906  Switzerland Plug : SEV Type 12, 250V, 10A Cable: 8120-2104
OPTION 904  U.S./ Canada Plug : NEMA 6-15P, 250V, 6A Cable: 8120-0698	OPTION 917  India/ Republic of S.Africa Plug : IEC 83-B1, 250V, 10A Cable: 8120-4211
OPTION 912  Denmark Plug : SR 107-2-D, 250V, 10A Cable: 8120-2956	OPTION 920  Argentina Plug : Argentine Resolution 63, Annex IV, 250V, 10A Cable: 8120-6870
OPTION 918  Japan Plug : JIS C 8303, 125V, 12A Cable: 8120-4753	OPTION 922  China Plug : GB 1002, 250V, 10A Cable: 8120-8376
OPTION 921  Chile Plug : CEI 23-16, 250V, 10A Cable: 8120-6978	OPTION 919  Israel Plug : Israel SI 32, 250V, 10A Cable: 8120-5182
OPTION 901  Australia/ New Zealand Plug : AS 3112, 250V, 10A Cable: 8120-1369	OPTION 927  Thailand Plug : NEMA 5-15P, 250V, 10A Cable: 8120-8871
NOTE: Each option number includes a 'family' of cords and connectors of various materials and plug body configurations (straight, 90° etc.).	

Top View (Major Assemblies)

Figure 5-2 Top View (Major Assemblies)

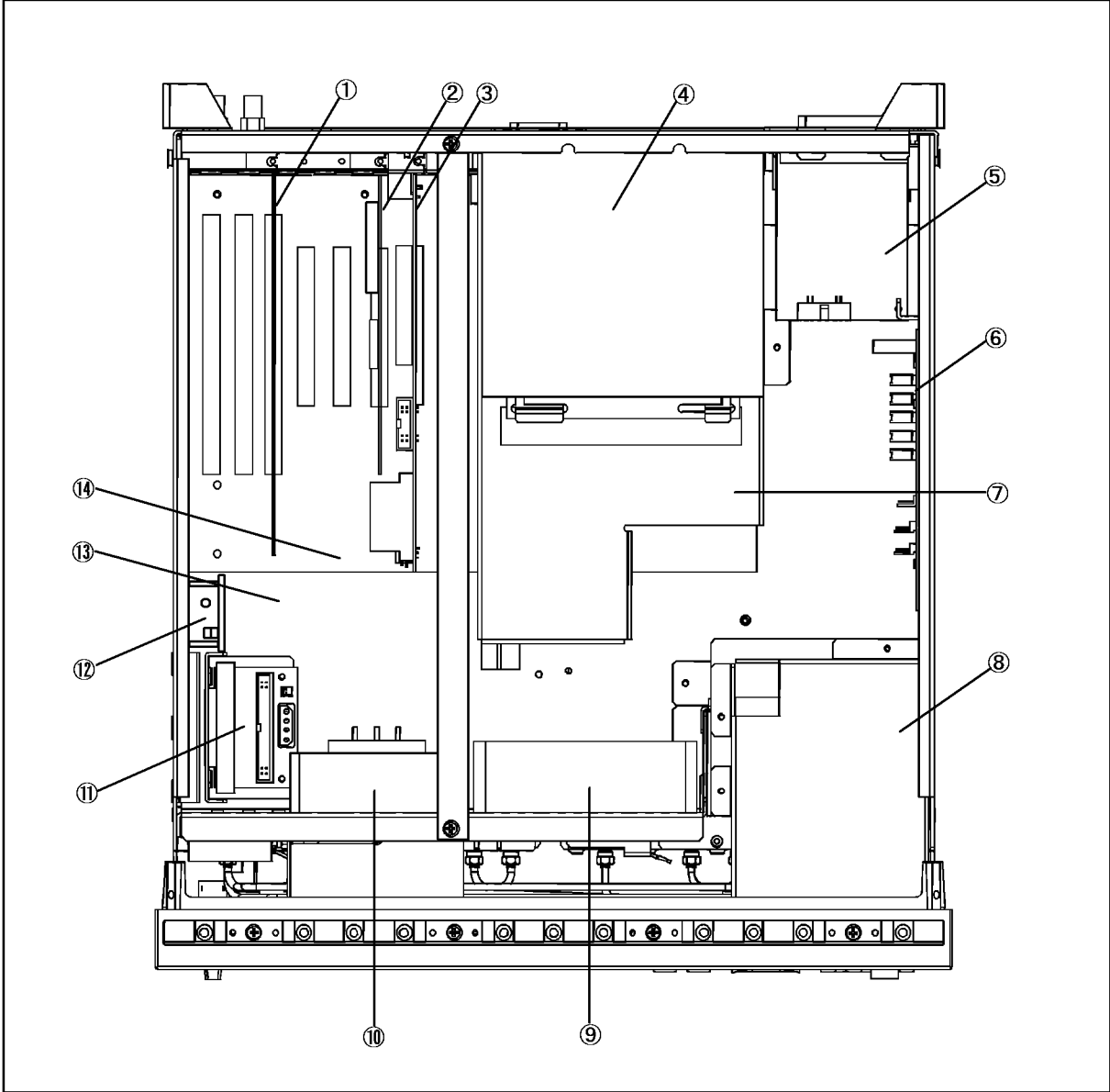

e5070ase069

Table 5-1 Top View (Major Assemblies)

Ref. Desig.	Agilent Part Number	C/D	Qty.	Description
1	54810-66525	1	1	A26 LCD INTERFACE CARD
2	82341C #002	8	1	A24 GPIB CARD
3	E5070-66521	5	1	A21 Interface BOARD
4	0950-3961	3	1	A50 ATX POWER SUPPLY
5	E5070-66523	7	1	A23 HANDLER I/O BOARD
6	E5070-66586	2	1	A6 SWITCH CONTROL BOARD
7	E5070-01251	2	1	PLATE
8	See Table 5-18	-	1	A28 FDD ASSEMBLY
9	E5070-61001	6	1	B1 FAN ASSY
10	E5070-61002	7	1	B1 FAN ASSY
11	See Table 5-19	-	1	A27 MASS STORAGE DISK DRIVE ASSEMBLY
12	E4991-66505	7	1	A5 CRYSTAL OVEN (Opt. 1E5)
13	E5070-60031	0	1	CHASSIS
14	E5070-61030	1	1	A20 DIGITAL MOTHERBOARD

Top View (Cables)

Figure 5-3 Top View (Cables)

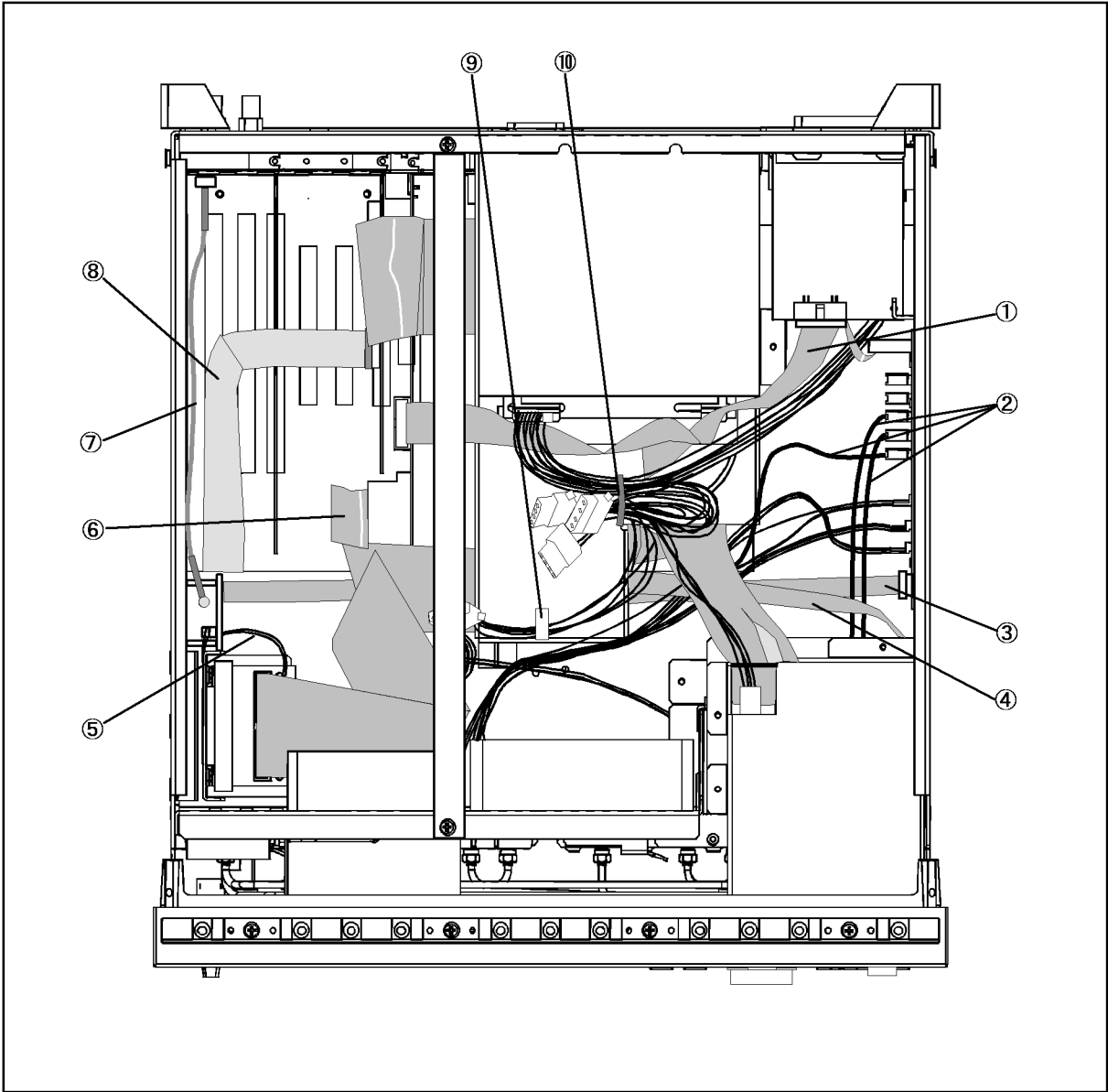

e5070ase070

Table 5-2 Top View (Cables)

Ref. Desig.	Agilent Part Number	C/D	Qty.	Description
1	E5070-61625	0	1	FLAT CABLE ASSY
2	E5070-61694	3	3	WIRE ASSY
3	E5070-61691	0	1	FLAT CABLE ASSY (Opt. x14)
4	E5070-61630	7	1	FLAT CABLE (Opt. 016)
5	E5070-61693	2	1	WIRE ASSY (Opt. 1E5)
6	See Table 5-31	-	1	CABLE ASSY
7	E5070-61692	1	1	RF CABLE ASSY (Opt. 1E5)
	1400-1334	6	1	CLAMP CABLE
8	E5070-61691	0	1	FLAT CABLE ASSY
9	1400-0584	6	1	MOUNT CABLE TIE
10	1400-0886	7	1	CLAMP CABLE

Top View (Miscellaneous Parts)

Figure 5-4 Top View (Miscellaneous Parts)

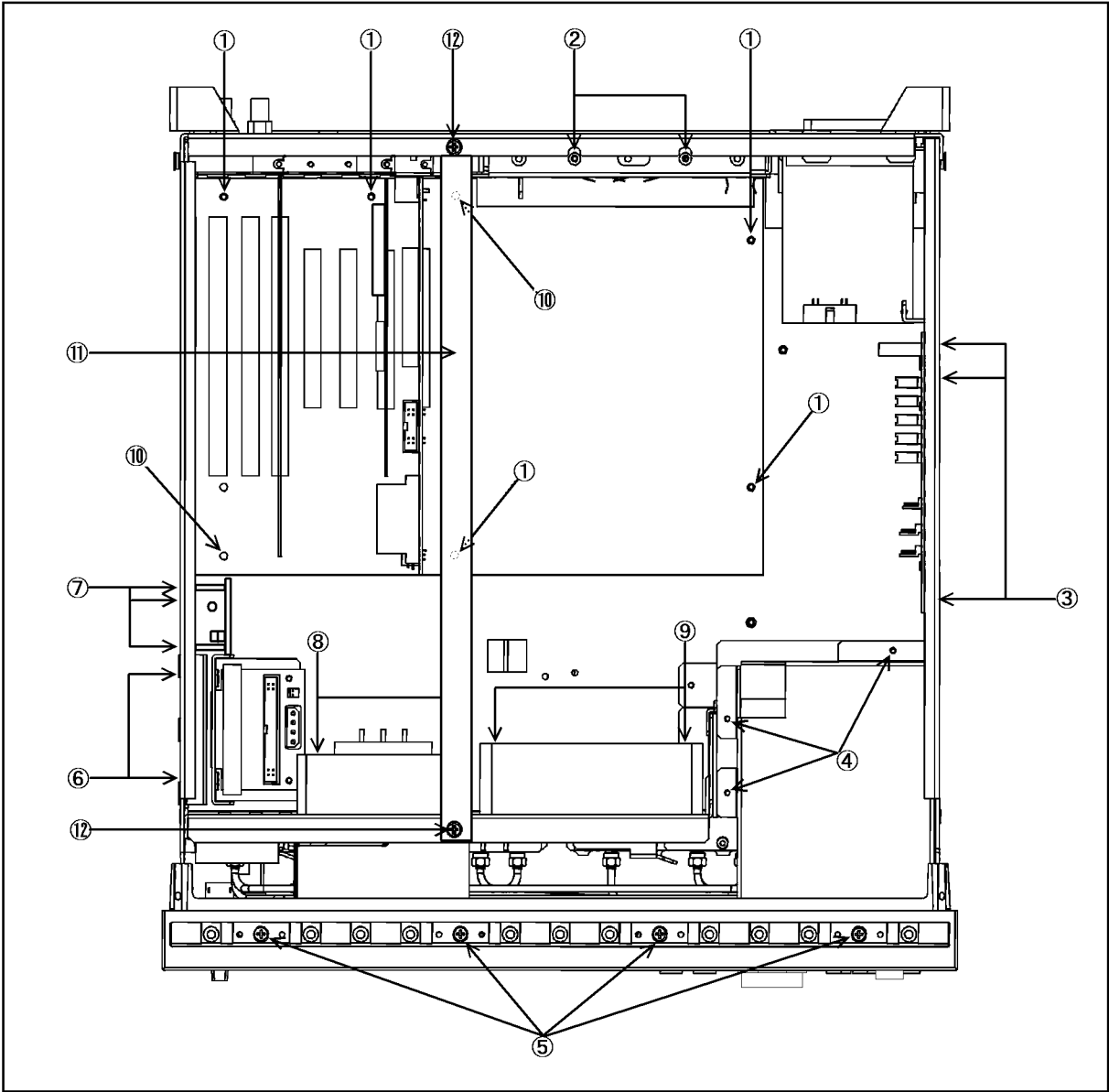

e5070ase071

Table 5-3 Top View (Miscellaneous Parts)

Ref. Desig.	Agilent Part Number	C/D	Qty.	Description
1	0515-0372	2	5	SCREW-MACH M3.0 x 8 PN T10
2	0515-1946	8	2	SCREW-MACH M3.0 x 6 FL T10
3	0515-1946	8	3	SCREW-MACH M3.0 x 6 FL T10
4	0515-0430	3	3	SCREW-MACH M3.0 x 6 PN T10
5	0515-1382	6	4	SCREW-MACH M3.5 x 6 FL T15
6	0515-0372	2	4	SCREW-MACH M3.0 x 8 PN T10
7	0515-1946	8	3	SCREW-MACH M3.0 x 6 FL T10 (Opt. 1E5)
8	0515-2216	7	4	SCREW-MACH M4.0 x 40 PN T20
9	0515-0964	8	4	SCREW-MACH M3.0 x 6 FL T10
10	E5070-24012	1	2	STAND OFF
	0515-0430	5	2	SCREW-MACH M3.0 x 6 PN T10
	2190-0584	0	2	WASHER
11	E5070-01219	2	1	ANGLE
12	0515-1946	8	2	SCREW-MACH M3.0 x 6 FL T10

Top View (Under Power Supply)

Figure 5-5 Top View (Under Power Supply)

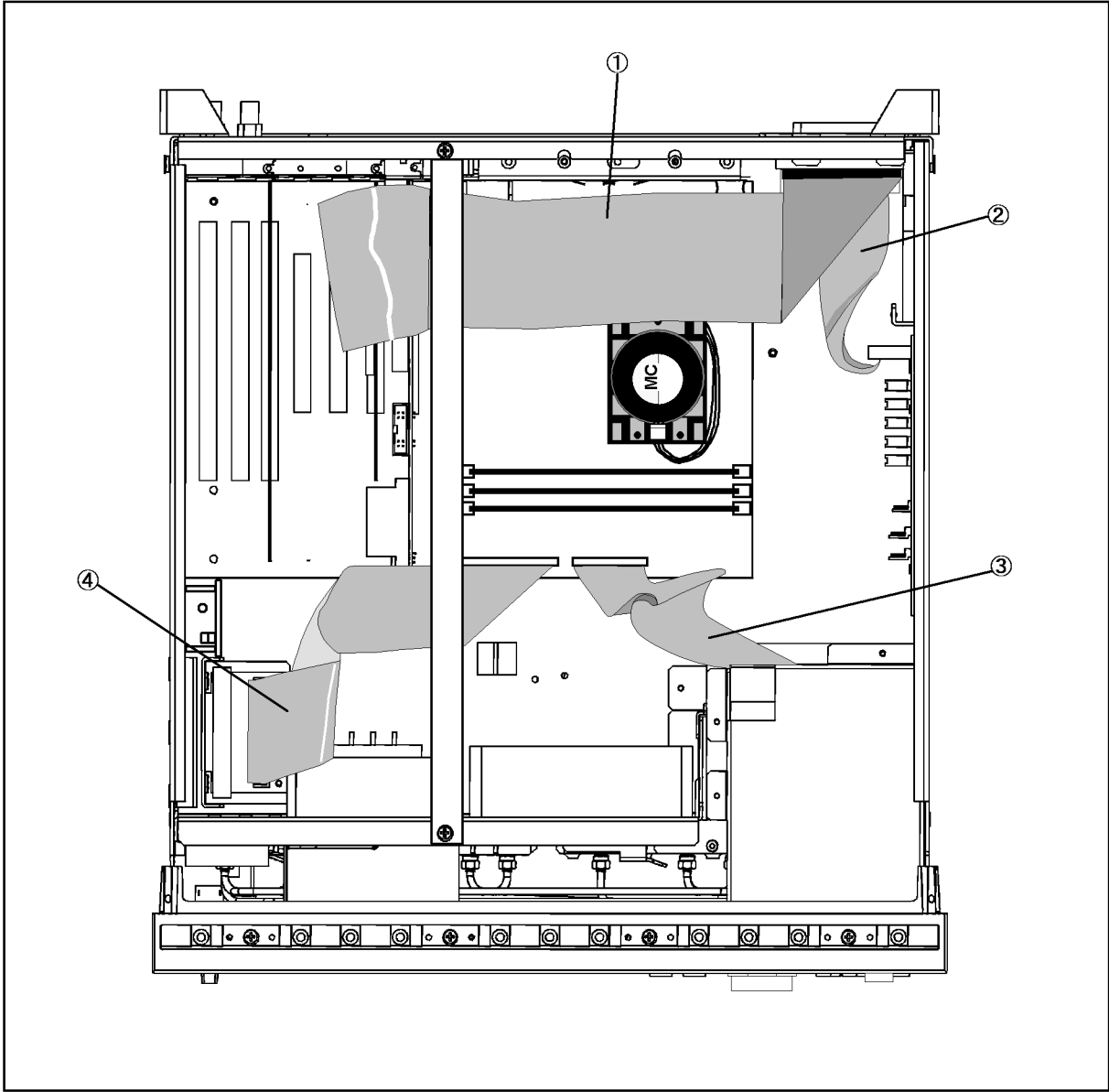

e5070ase073

Table 5-4 **Top View (Under Power Supply)**

Ref. Desig.	Agilent Part Number	C/D	Qty.	Description
1	E5070-61621	6	1	FLAT CBL ASSY
2	E5070-61629	4	1	FLAT CBL ASSY
3	E5070-61623	8	1	FLAT CBL ASSY
4	E5070-61624	9	1	FLAT CBL ASSY

Top View (Motherboard and Other Parts)

Figure 5-6 Top View (Motherboard and Other Parts)

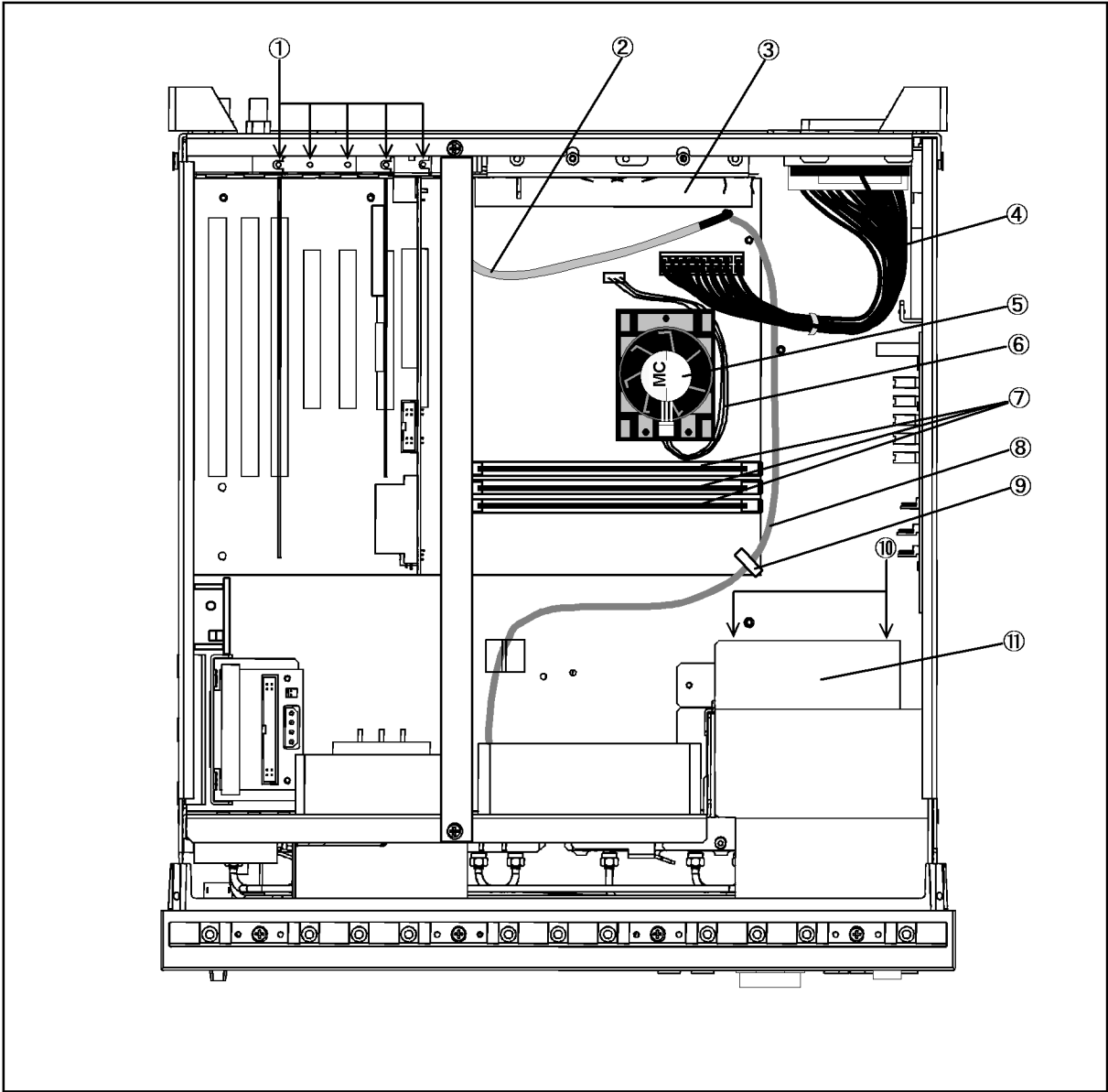

e5070ase072

Table 5-5 Top View (Motherboard and Other Parts)

Ref. Desig.	Agilent Part Number	C/D	Qty.	Description
1	0515-0430	3	5	SCREW-MACH M3.0 x 6 PN T10
2	E5070-61696	5	1	USB CABLE
	E5070-01217	0	1	BRACKET USB
	2200-0141	8	2	SCREW-MACH M4 x 40 PN
3	E5070-01208	9	1	COVER REAR I/O
4	E5070-61626	1	1	WIRE ASSY
5	3160-4126	2	1	FAN-TRAX
	1821-8660	0	1	IC 80526 (Pentium 3, 850 MHz)
6	E5070-61695	4	1	WIRE ASSY
7	1818-8150	3	3	SYNC-DIMM 16MX64
	1400-3207	6	3	CABLE TIE
8	E5070-61697	6	1	USB CABLE
9	1400-0249	0	1	CABLE TIE
10	0515-2216	7	1	SCREW-MACH M4.0 x 40 PN T20
11	04287-61001	8	1	FAN ASSY
	E5070-01216	9	1	BRACKET FAN

Replaceable Parts
 Replaceable Parts List

Front View (Analog)

Figure 5-7 Front View (Analog)

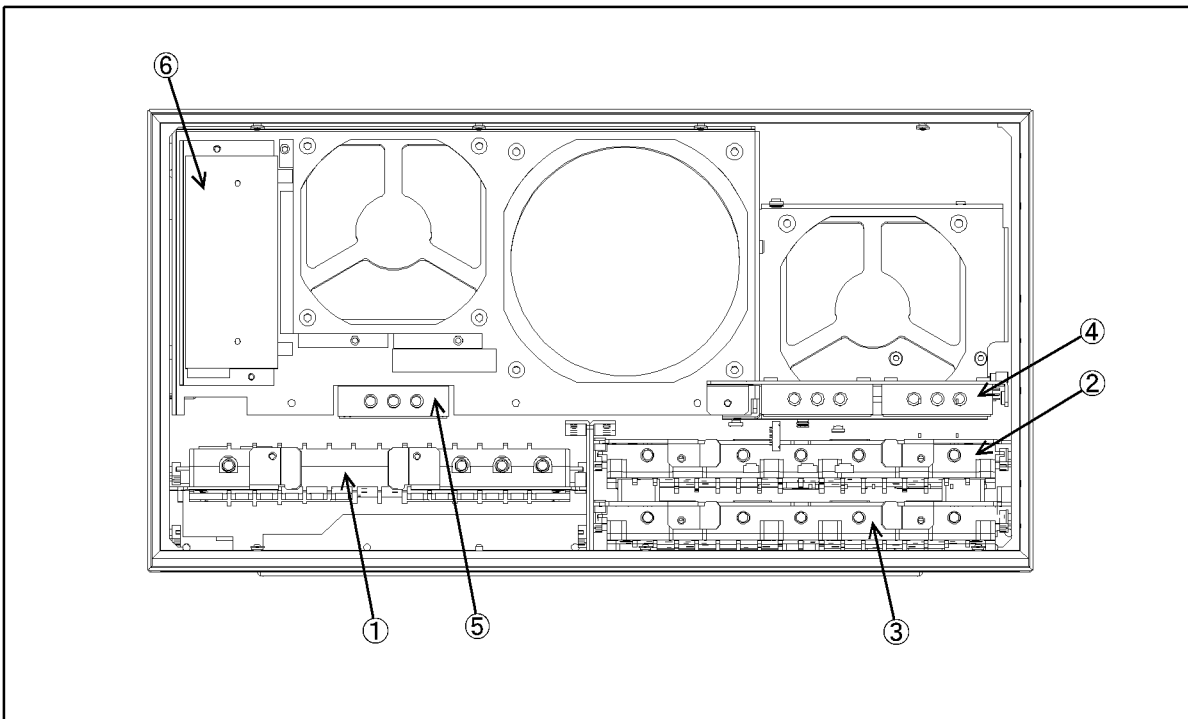

e5070ase283

Table 5-6 Front View (Analog)

Ref. Desig.	Agilent Part Number	C/D	Qty.	Description
1	E5071-66551	2	1	A1 SOURCE BOARD
	E5071-69551	8	1	A1 SOURCE BOARD (Exchange)
2	See Table 5-23	-	1	A2 RECEIVER BOARD
3	See Table 5-23	-	1	A2 RECEIVER BOARD (Opt. 31x, 41x)
4	See Table 5-21	-	1	A8 RF SWITCH ASSEMBLY
5	5087-7137	7	1	A8 SWITCH RF SPDT (Opt. 31x, 41x)
6	See Table 5-22	-	1	STEP ATTENUATOR ASSEMBLY (Opt. 214, 314, 414)

Front View (Miscellaneous Parts)

Figure 5-8 Front View (Miscellaneous Parts)

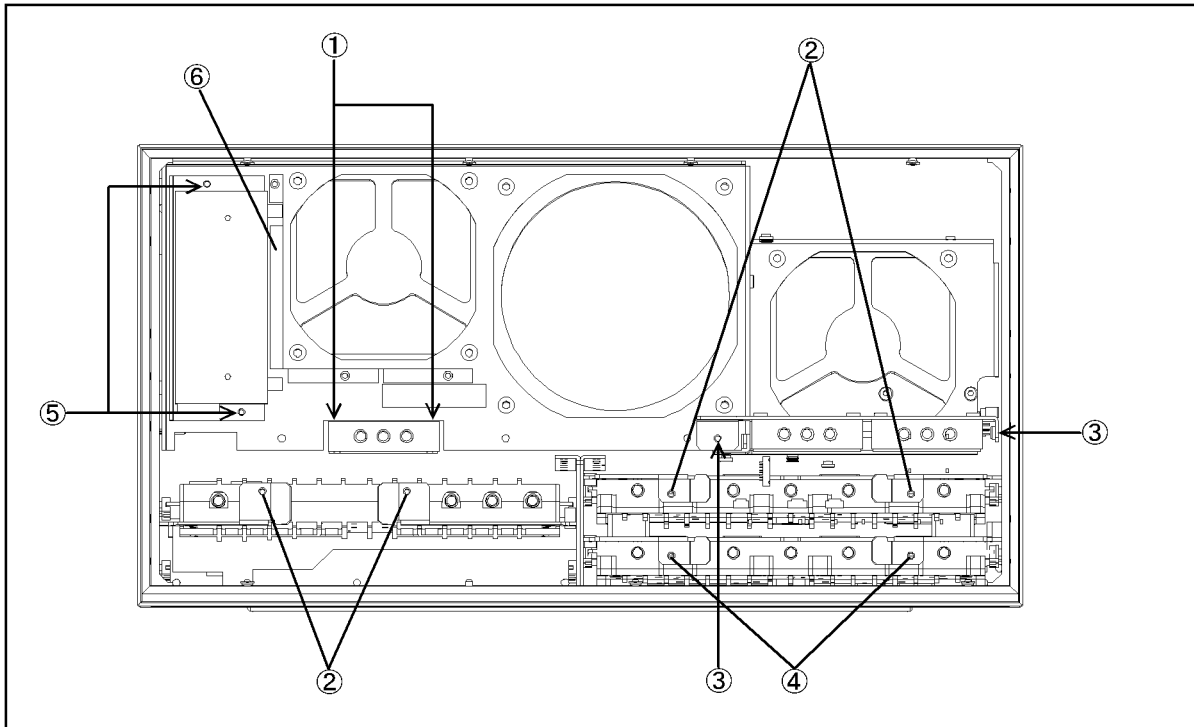

e5070ase125

Table 5-7 Front View (Miscellaneous Parts)

Ref. Desig.	Agilent Part Number	C/D	Qty.	Description
1	0515-1410	1	2	SCREW-MACH M3.0 x 20 PN T10
2	0515-0372	2	4	SCREW-MACH M3.0 x 8 PN T10
3	0515-0372	2	2	SCREW-MACH M3.0 x 8 PN T10
4	0515-0372	2	2	SCREW-MACH M3.0 x 8 PN T10 (Opt. 31x, 41x)
5	0515-0372	2	2	SCREW-MACH M3.0 x 8 PN T10
6	E5070-01212	5	1	PLATE

Front View (Semirigid Cables) (Opt. 213)

Figure 5-9 Front View (Semirigid Cables) (Opt. 213)

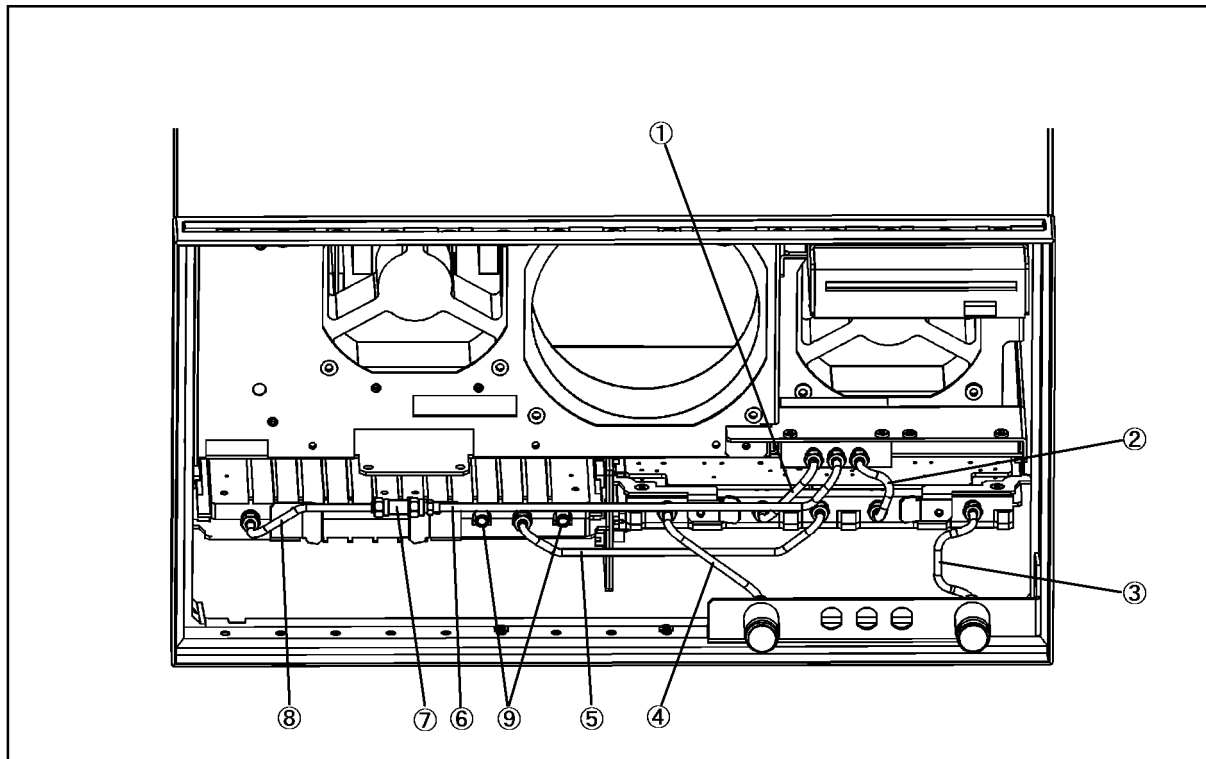

e5070ase074

Table 5-8 Front View (Semirigid Cables) (Opt. 213)

Ref. Desig.	Agilent Part Number	C/D	Qty.	Description
1	E5070-61645	4	1	RF CABLE ASSY SRGD
2	E5070-61603	4	1	RF CABLE ASSY SRGD
3	E5070-61606	7	1	RF CABLE ASSY SRGD
4	E5070-61605	6	1	RF CABLE ASSY SRGD
5	E5070-61604	5	1	RF CABLE ASSY SRGD
6	E5070-61602	3	1	RF CABLE ASSY SRGD
7	0955-0208	5	1	U-WAVE ATTN 4DB
8	E5070-61601	2	1	RF CABLE ASSY SRGD
9	1810-0118	1	2	TERMINATION-COAX

Front View (Semirigid Cables) (Opt. 214)

Figure 5-10 Front View (Semirigid Cables) (Opt. 214)

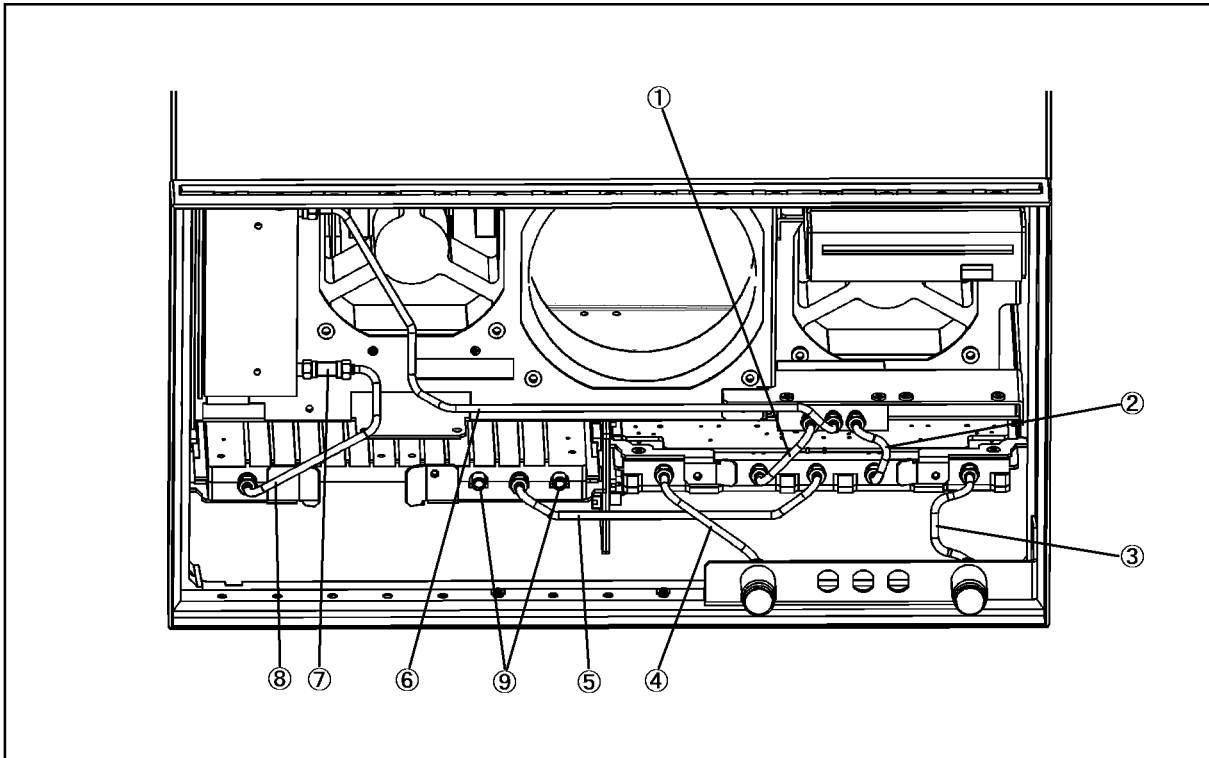

e5070ase075

Table 5-9 Front View (Semirigid Cables) (Opt. 214)

Ref. Desig.	Agilent Part Number	C/D	Qty.	Description
1	E5070-61645	4	1	RF CABLE ASSY SRGD
2	E5070-61603	4	1	RF CABLE ASSY SRGD
3	E5070-61606	7	1	RF CABLE ASSY SRGD
4	E5070-61605	6	1	RF CABLE ASSY SRGD
5	E5070-61604	5	1	RF CABLE ASSY SRGD
6	E5070-61608	9	1	RF CABLE ASSY SRGD
7	0955-0208	5	1	U-WAVE ATTN 4DB
8	E5070-61607	8	1	RF CABLE ASSY SRGD
9	1810-0118	1	2	TERMINATION-COAX

Front View (Semirigid Cables) (Opt. 313)

Figure 5-11 Front View (Semirigid Cables) (Opt. 313)

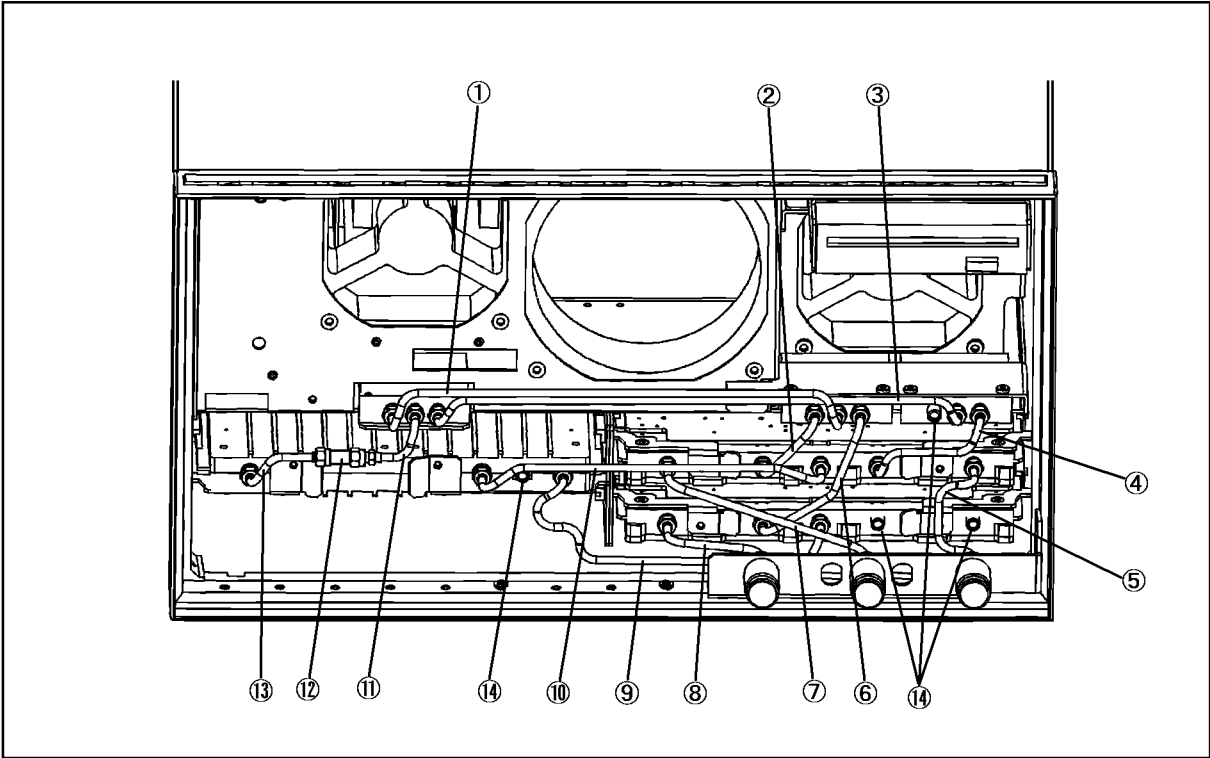

e5070ase076

Table 5-10 Front View (Semirigid Cables) (Opt. 313)

Ref. Desig.	Agilent Part Number	C/D	Qty.	Description
1	E5070-61643	2	1	RF CABLE ASSY SRGD
2	E5070-61645	4	1	RF CABLE ASSY SRGD
3	E5070-61644	3	1	RF CABLE ASSY SRGD
4	E5070-61648	7	1	RF CABLE ASSY SRGD
5	E5070-61632	9	1	RF CABLE ASSY SRGD
6	E5070-61646	5	1	RF CABLE ASSY SRGD
7	E5070-61631	8	1	RF CABLE ASSY SRGD
8	E5070-61651	2	1	RF CABLE ASSY SRGD
9	E5070-61650	1	1	RF CABLE ASSY SRGD
10	E5070-61649	8	1	RF CABLE ASSY SRGD
11	E5070-61642	1	1	RF CABLE ASSY SRGD
12	0955-0301	9	1	U-WAVE ATTN 2DB
13	E5070-61641	0	1	RF CABLE ASSY SRGD
14	1810-0188	1	4	TERMINATION-COAX

Front View (Semirigid Cables) (Opt. 314)

Figure 5-12

Front View (Semirigid Cables) (Opt. 314)

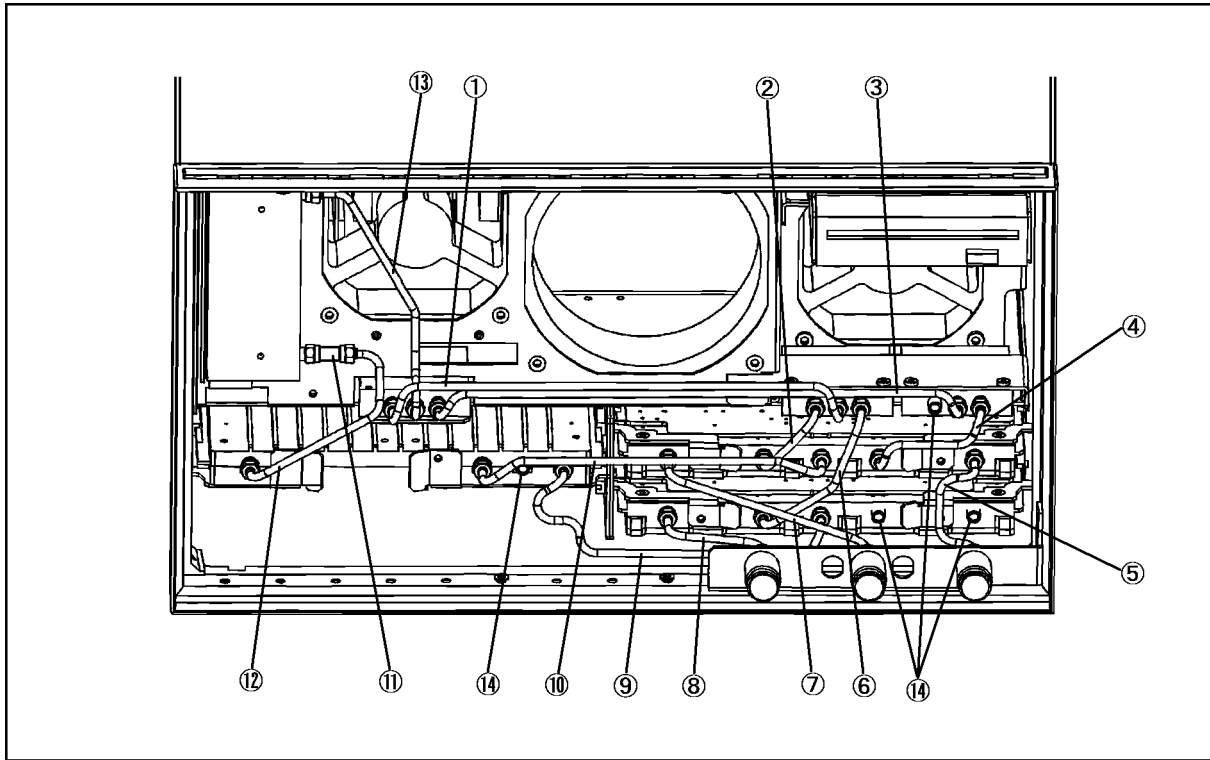

e5070ase077

Table 5-11 Front View (Semirigid Cables) (Opt. 314)

Ref. Desig.	Agilent Part Number	C/D	Qty.	Description
1	E5070-61643	2	1	RF CABLE ASSY SRGD
2	E5070-61645	4	1	RF CABLE ASSY SRGD
3	E5070-61644	3	1	RF CABLE ASSY SRGD
4	E5070-61648	7	1	RF CABLE ASSY SRGD
5	E5070-61632	9	1	RF CABLE ASSY SRGD
6	E5070-61646	5	1	RF CABLE ASSY SRGD
7	E5070-61631	8	1	RF CABLE ASSY SRGD
8	E5070-61651	2	1	RF CABLE ASSY SRGD
9	E5070-61650	1	1	RF CABLE ASSY SRGD
10	E5070-61649	8	1	RF CABLE ASSY SRGD
11	0955-0301	9	1	U-WAVE ATTN 2DB
12	E5070-61607	8	1	RF CABLE ASSY SRGD
13	E5070-61656	7	1	RF CABLE ASSY SRGD
14	1810-0188	1	2	TERMINATION-COAX

Front View (Semirigid Cables) (Opt. 413)

Figure 5-13

Front View (Semirigid Cables) (Opt. 413)

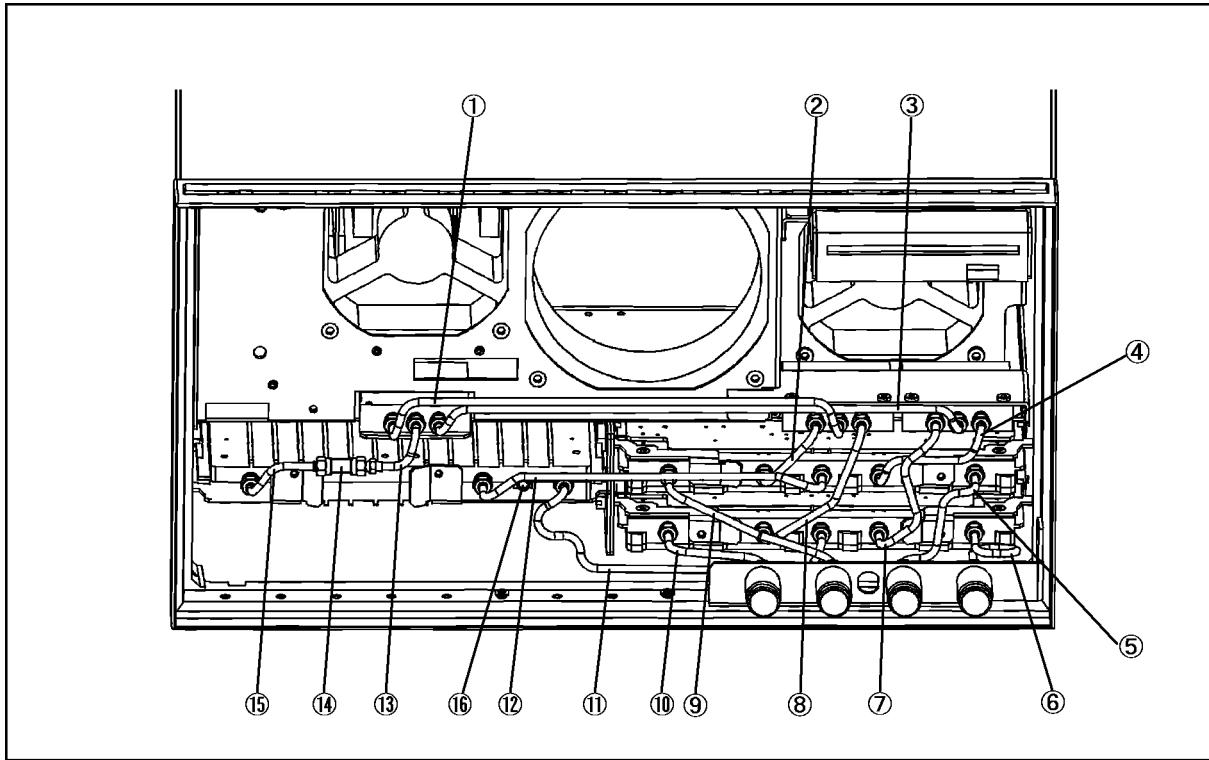

e5070ase289

Table 5-12 Front View (Semirigid Cables) (Opt. 413)

Ref. Desig.	Agilent Part Number	C/D	Qty.	Description
1	E5070-61643	2	1	RF CABLE ASSY SRGD
2	E5070-61645	4	1	RF CABLE ASSY SRGD
3	E5070-61644	3	1	RF CABLE ASSY SRGD
4	E5070-61648	7	1	RF CABLE ASSY SRGD
5	E5070-61632	9	1	RF CABLE ASSY SRGD
6	E5070-61654	5	1	RF CABLE ASSY SRGD
7	E5070-61647	8	1	RF CABLE ASSY SRGD
8	E5070-61646	5	1	RF CABLE ASSY SRGD
9	E5070-61631	8	1	RF CABLE ASSY SRGD
10	E5070-61651	2	1	RF CABLE ASSY SRGD
11	E5070-61650	1	1	RF CABLE ASSY SRGD
12	E5070-61649	8	1	RF CABLE ASSY SRGD
13	E5070-61642	1	1	RF CABLE ASSY SRGD
14	0955-0301	9	1	U-WAVE ATTN 2DB
15	E5070-61641	0	1	RF CABLE ASSY SRGD
16	1810-0118	1	1	TERMINATION-COAX

Front View (Semirigid Cables) (Opt. 414)

Figure 5-14 Front View (Semirigid Cables) (Opt. 414)

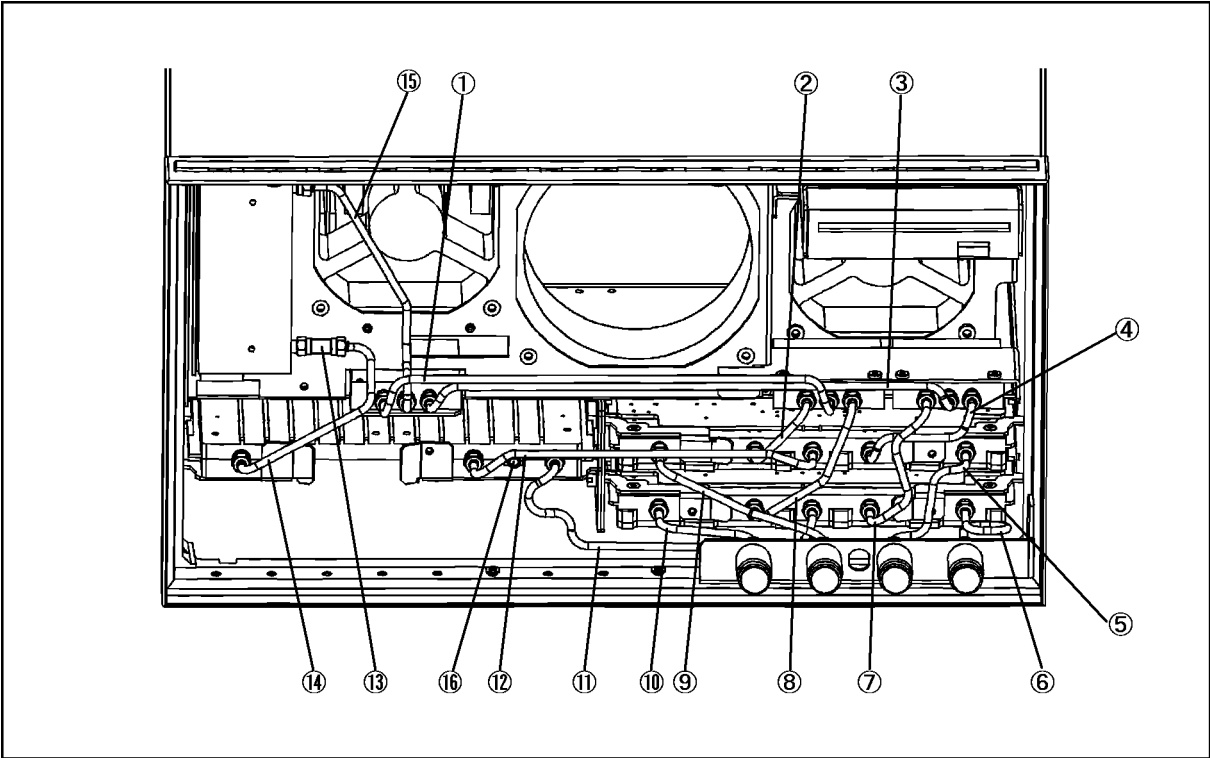

e5070ase290

Table 5-13 Front View (Semirigid Cables) (Opt. 414)

Ref. Desig.	Agilent Part Number	C/D	Qty.	Description
1	E5070-61643	2	1	RF CABLE ASSY SRGD
2	E5070-61645	4	1	RF CABLE ASSY SRGD
3	E5070-61644	3	1	RF CABLE ASSY SRGD
4	E5070-61648	7	1	RF CABLE ASSY SRGD
5	E5070-61632	9	1	RF CABLE ASSY SRGD
6	E5070-61654	5	1	RF CABLE ASSY SRGD
7	E5070-61647	6	1	RF CABLE ASSY SRGD
8	E5070-61646	5	1	RF CABLE ASSY SRGD
9	E5070-61631	8	1	RF CABLE ASSY SRGD
10	E5070-61651	2	1	RF CABLE ASSY SRGD
11	E5070-61650	1	1	RF CABLE ASSY SRGD
12	E5070-61649	8	1	RF CABLE ASSY SRGD
13	0955-0301	9	1	U-WAVE ATTN 2DB
14	E5070-61607	8	1	RF CABLE ASSY SRGD
15	E5070-61656	7	1	RF CABLE ASSY SRGD
16	1810-0118	1	1	TERMINATION-COAX

Front Panel

Figure 5-15 Front Panel

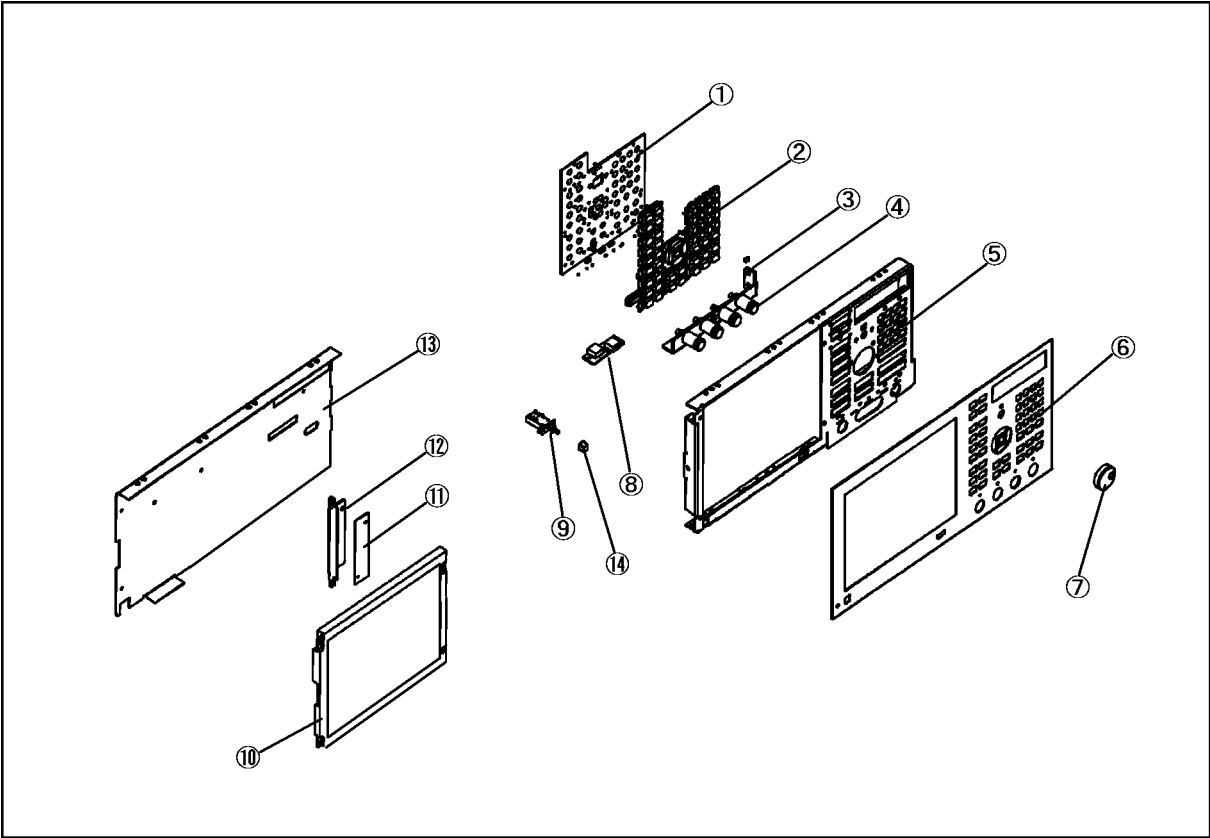

e5070ase080

Table 5-14 Front Panel

Ref. Desig.	Agilent Part Number	C/D	Qty.	Description
1	E5070-66522	6	1	A22 FRONT PANEL KEYBOARD
2	E5070-25101	1	1	KEYPAD RUBBER
3	E5070-01231	8	1	ANGLE-N-CONN
4	86290-60005	7	1	CONN TP N ASSY
	2190-0104	0	1	WSHR-LK INTL T
	2950-0132	6	1	NUT-HEX-DUB-CHAM
5	E5070-00202	1	1	PANEL SUB
6	E5070-00201	0	1	PANEL FRONT (E5070A Opt. 21x)
	E5070-00203	2	1	PANEL FRONT (E5070A Opt. 31x)
	E5070-00204	3	1	PANEL FRONT (E5070A Opt. 41x)
	E5071-00201	0	1	PANEL FRONT (E5071A Opt. 21x)
	E5071-00203	2	1	PANEL FRONT (E5071A Opt. 31x)
	E5071-00204	3	1	PANEL FRONT (E5071A Opt. 41x)
7	5182-7594	2	1	KNOB
8	E5070-66532	8	1	USB Adapter
	0515-0430	2	3	SCREW-MACH M3.0 x 6 PN T10
9	See Table 5-29	-	1	STANDBY SWITCH ASSEMBLY
10	E5070-60101	5	1	LCD-FILTER ASSY (Standard)
	E5070-60102	5	1	LCD-TPANEL ASSY (Opt. 016)
	2090-0888	5	1	BACKLIGHT (included in LCD ASSY)
11	0950-4091	2	1	A52 INVERTER LS700
	0515-1974	2	2	SCREW-MACH M2.5 x 4 PN T8
12	E5070-01211	4	1	BRACKET INVERTER
13	E5070-00601	4	1	COVER SHIELD
14	5041-0564	4	1	KEY CAP

Replaceable Parts
 Replaceable Parts List

Rear View

Figure 5-16

Rear View

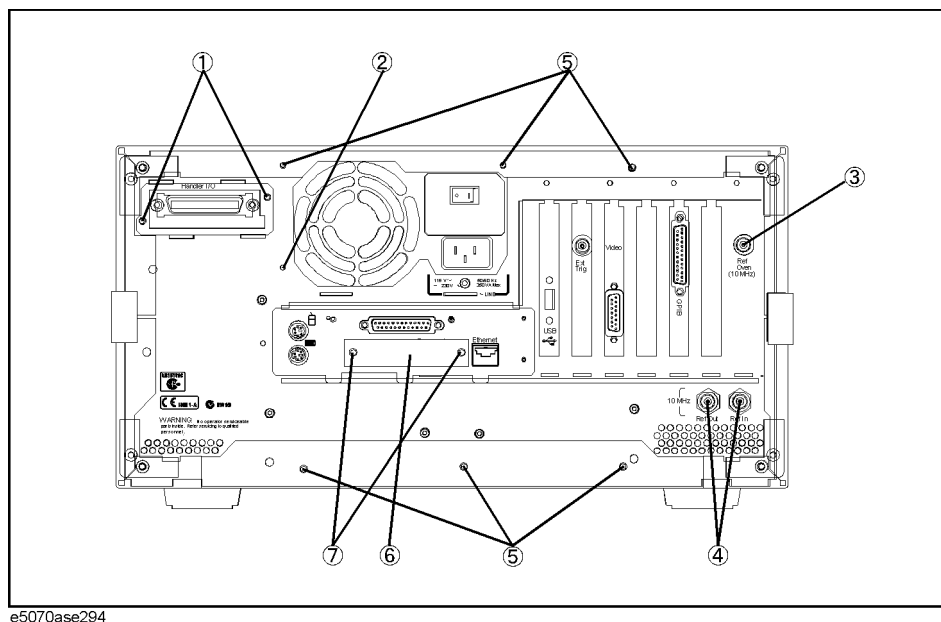

Table 5-15

Rear View

Ref. Desig.	Agilent Part Number	C/D	Qty.	Description
1	0515-0372	2	2	SCREW-MACH M3.0 x 8 PN T10
2	0515-1402	2	1	SCREW-MACH M3.5 x 8 PN T15
3	1250-0252	6	1	BNC CONNECTOR (Opt. 1E5)
	2950-0035	8	1	NUT-HEX-DBL-CHAM (Opt. 1E5)
	2190-0102	8	1	WSHR-LK INTL T (Opt. 1E5)
	6960-0041	1	1	PLUG HOLE
4	2950-0054	1	2	NUT-HEX-DBL-CHAM
	2190-0054	9	2	WSHR-LK INTL T
5	0515-1402	5	6	SCREW-MACH M3.5 x 8 PN T15
6	E5070-04004	9	1	COVER CONNECTOR
7	2200-0155	4	2	SCREW- MACH 4-40

Side View

Figure 5-17

Side View

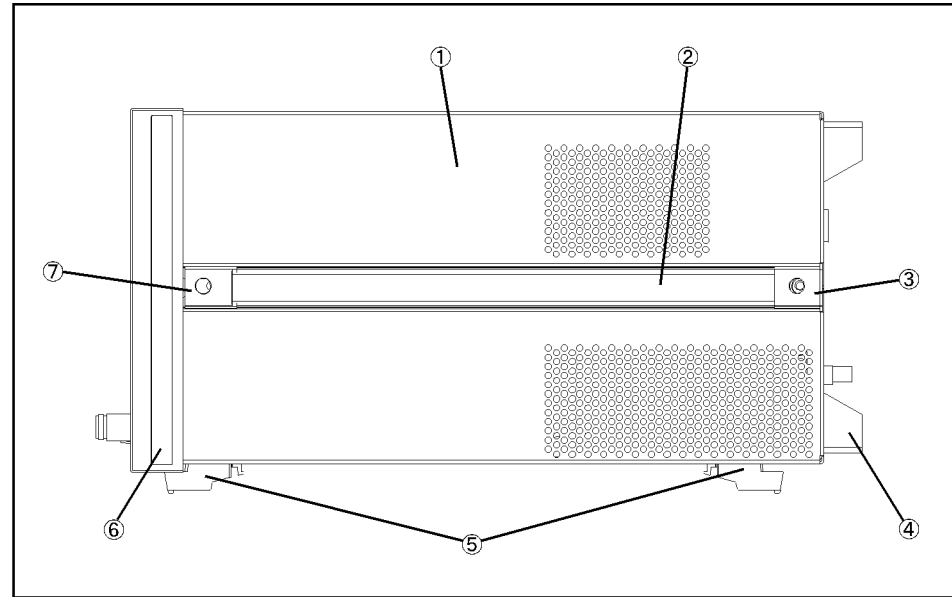

e5070ase053

Table 5-16

Side View

Ref. Desig.	Agilent Part Number	C/D	Qty.	Description
1	E5070-60032	1	1	COVER ASSY
2	08720-00081	0	2	STRAP HANDLE
3	5041-9187	5	2	STRAP HANDL REAR
	0515-2049	8	2	SCREW-MACH M5.0 x 16 FL T20
4	E5100-40002	0	4	STANDOFF
	0515-1402	5	4	SCREW-MACH M3.5 x 8 PN T15
5	5041-9167	1	4	FOOT FL
	1460-1345	5	2	WIREFORM
6	5041-9173	9	2	SIDE TRIM 221.5
7	5041-9186	4	2	STRAP HANDLE FRT
	0515-2049	8	2	SCREW-MACH M5.0 x 16 FL T20

Cover Assembly

Figure 5-18 **Cover Assembly**

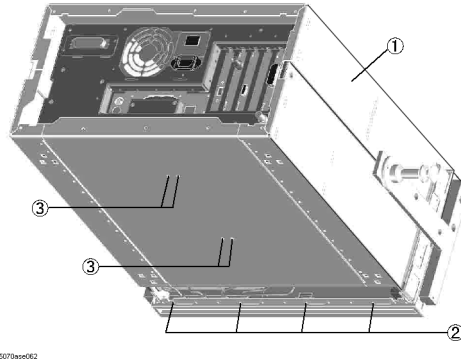
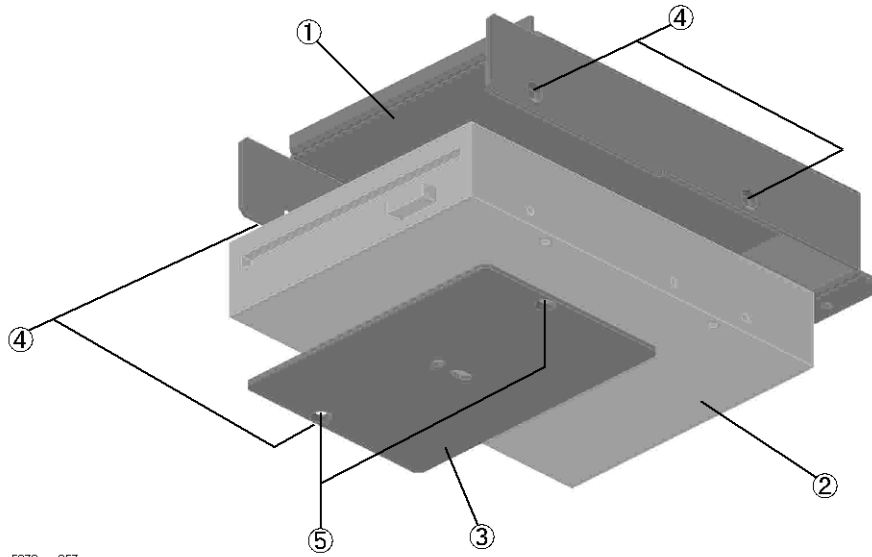

Table 5-17 **Cover Assembly**

Ref. Desig.	Agilent Part Number	C/D	Qty.	Description
1	E5070-60032	5	1	COVER ASSY
2	0515-1382	6	4	SCREW-MACH M3.5 x 6 FL T15
3	0515-0430	3	4	SCREW-MACH M3.0 x 6 PN T10

A28 FDD Assembly

Figure 5-19 A28 FDD Assembly



e5070ase057

Table 5-18 A28 FDD Assembly

Ref. Desig.	Agilent Part Number	C/D	Qty.	Description
1	E5070-01203	4	1	HOLDER FDD
2	0950-3334	4	1	A28 FDD 3.5
3	E5070-04005	0	1	COVER FDD
4	0515-2146	2	4	SCREW-MACH M3.0 x 4 FL T10
5	0515-2146	2	2	SCREW-MACH M3.0 x 4 FL T10

A27 Mass Storage Disk Drive Assembly

Figure 5-20

A27 Mass Storage Disk Drive Assembly

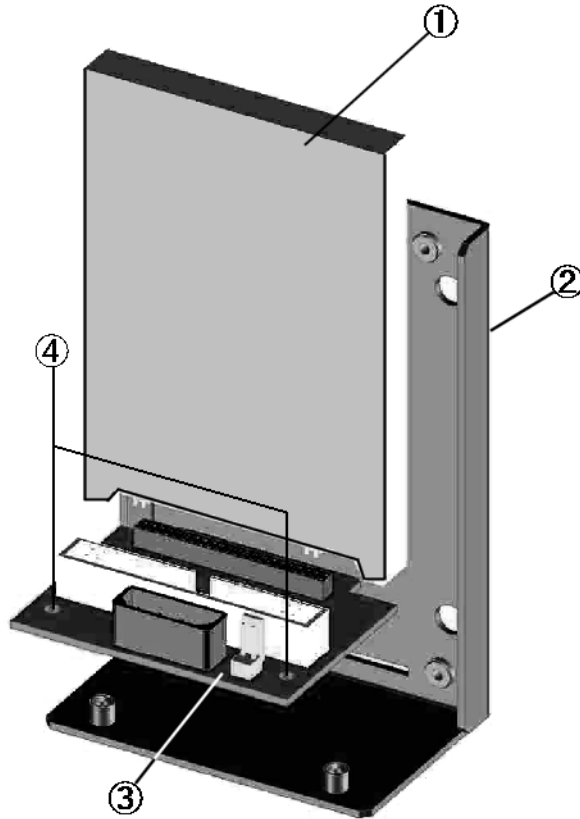

e5070ase055

Table 5-19 A27 Mass Storage Disk Drive Assembly

Ref. Desig.	Agilent Part Number	C/D	Qty.	Description
1	E5070-65030	9	1	A27 MASS STRAGE DISK DRIVE (HDD)
2	E5070-01205	6	1	HOLDER HDD
3	E5070-66530	6	1	DISK DR
4	0515-0372	2	2	SCREW-MACH M3.0 x 8 PN T10

Figure 5-21 A27 Mass Storage Disk Drive Mount Assembly

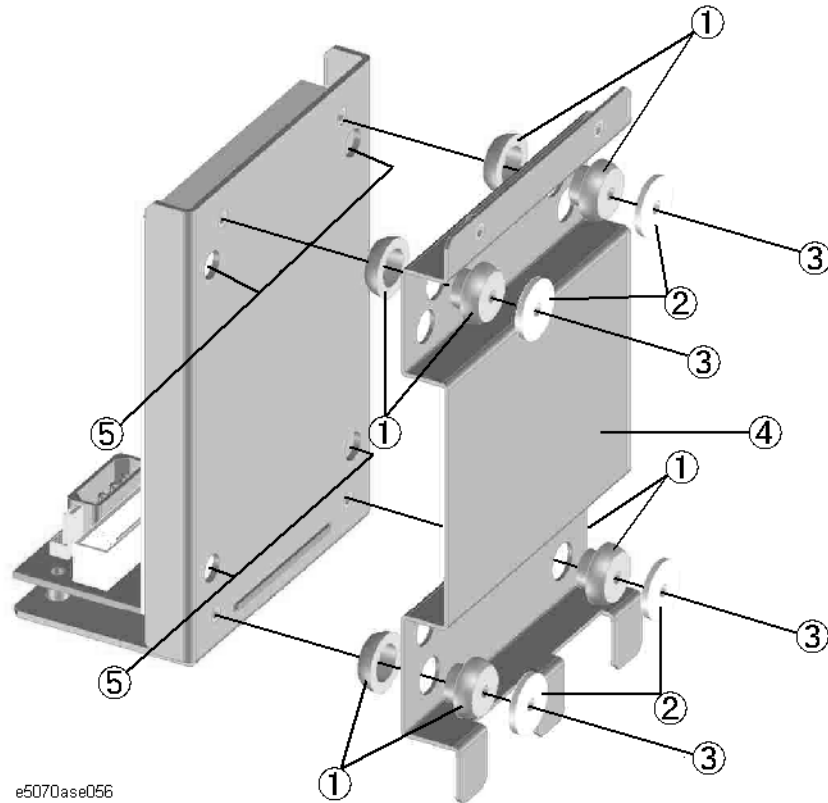
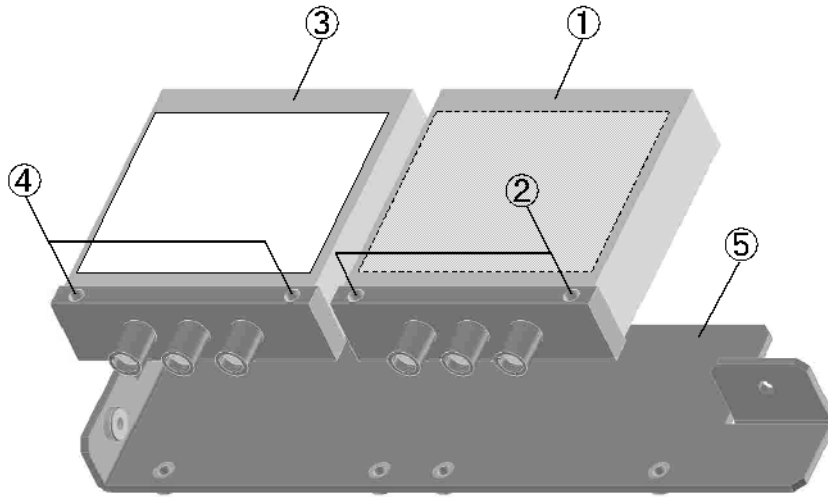

Table 5-20 A27 Mass Storage Disk Drive Mount Assembly

Ref. Desig.	Agilent Part Number	C/D	Qty.	Description
1	1410-1580	5	1	BUSHING
2	E5070-24011	0	4	SPACER
3	0515-0665	6	4	SCREW-MACH M3.0 x 14 PN T10
4	E5070-01206	7	1	BRACKET HDD
5	0515-0374	4	4	SCREW-MACH M3.0 x 10 PN T10

A8 RF Switch Assembly

Figure 5-22 A8 RF Switch Assembly



e5070ase058

Table 5-21 A8 RF Switch Assembly

Ref. Desig.	Agilent Part Number	C/D	Qty.	Description
1	5087-7137	7	1	SWITCH RF SPDT (Opt. 21x, 31x, 41x)
2	0515-1410	1	2	SCREW-MACH M3.0 x 20 PN T10 (Opt. 21x, 31x, 41x)
3	5087-7137	7	1	SWITCH RF SPDT (Opt. 31x, 41x)
4	0515-1410	1	2	SCREW-MACH M3.0 x 20 PN T10 (Opt. 31x, 41x)
5	E5070-01209	0	1	PLATE SWITCH

A7 Source Step Attenuator Assembly (Opt. 214, 314, 414)

Figure 5-23

A7 Source Step Attenuator Assembly (Opt. 214, 314, 414)

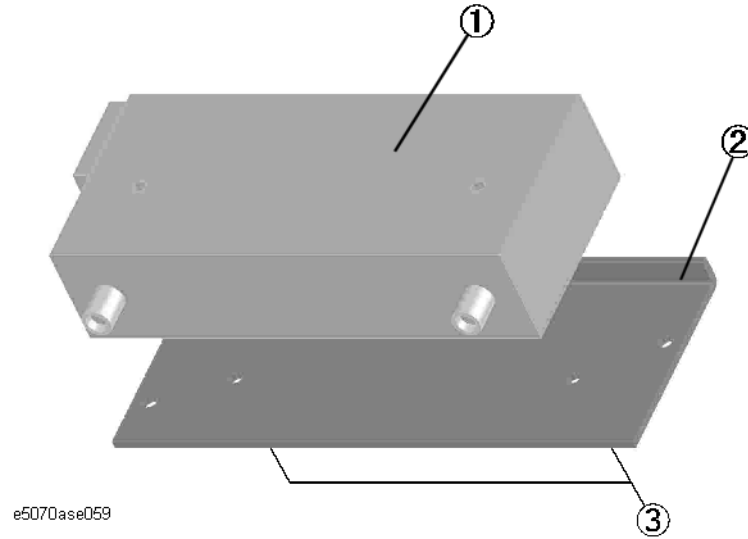
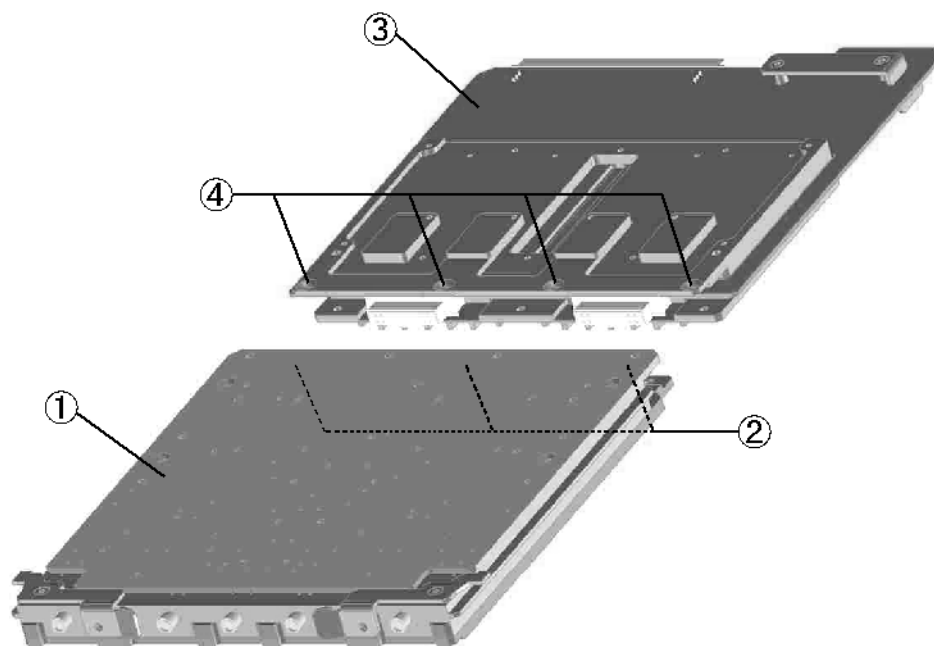

Table 5-22 A7 Source Step Attenuator Assembly (Opt. 214, 314, 414)

Ref. Desig.	Agilent Part Number	C/D	Qty.	Description
1	33321-60059	8	1	A7 Source Step Attenuator
2	E5070-01213	6	1	PLATE
3	0515-0372	2	2	SCREW-MACH M3.0 x 8 PN T10

A2 Receiver Board Assembly

Figure 5-24 A2 Receiver Board Assembly



e5070ase060
 Table 5-23 A2 Receiver Board Assembly

Ref. Desig.	Agilent Part Number	C/D	Qty.	Description
1	E5071-61014	2	1	A14 RECEIVER- RF BOARD (Opt. 21x)
	E5071-69014	8	1	A14 RECEIVER- RF BOARD (Exchange)
2	0515-1403	2	3	SCREW-MACH M4.0 x 6 FN T15 (Opt. 21x)
3	E5071-66517	0	1	A17 RECEIVER-IF BOARD (Opt. 21x)
4	0515-1403	2	4	SCREW-MACH M4.0 x 6 FN T15 (Opt. 21x)
1	E5071-61014	2	2	A14 RECEIVER-RF BOARD (Opt. 31x, 41x)
	E5071-69014	8	1	A14 RECEIVER- RF BOARD (Exchange)
2	0515-1403	2	6	SCREW-MACH M4.0 x 6 FN T15 (Opt. 31x, 41x)
3	E5071-66517	0	2	A17 RECIEVER-IF BOARD (Opt. 31x, 41x)
4	0515-1403	2	8	SCREW-MACH M4.0 x 6 FN T15 (Opt. 31x, 41x)

Receiver Module Assembly (Opt. 31x, 41x)

Figure 5-25

Receiver Module Assembly (Opt. 31x, 41x)

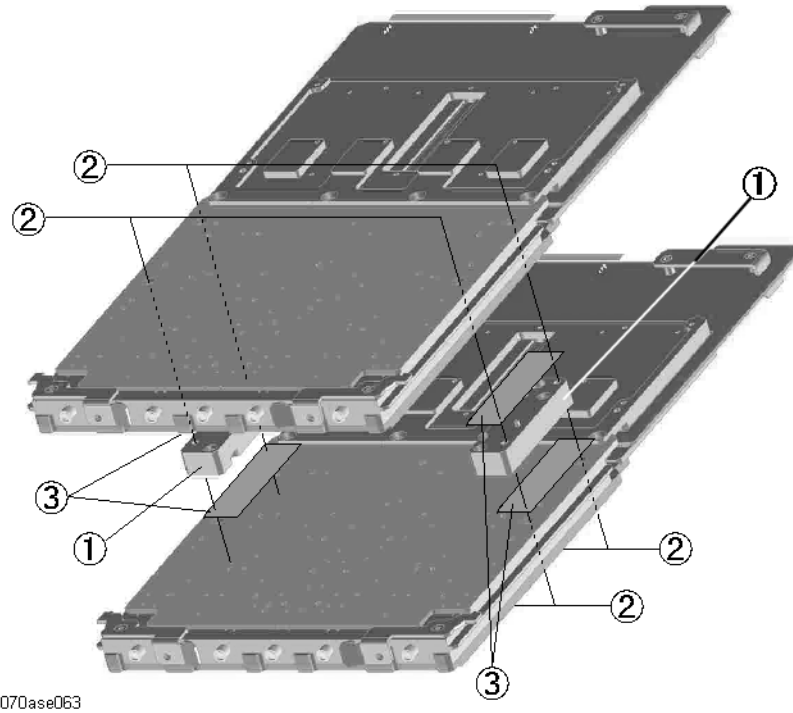

Table 5-24

Receiver Module Assembly (Opt. 31x, 41x)

Ref. Desig.	Agilent Part Number	C/D	Qty.	Description
1	E5070-20031	6	2	BLOCK
2	0515-1864	9	8	SCREW-MACH M3.0 x 22 FL T10
3	E5070-25031	6	4	SHEET TERMAL

Analog Mother Board Assembly

Figure 5-26 Analog Mother Board Assembly

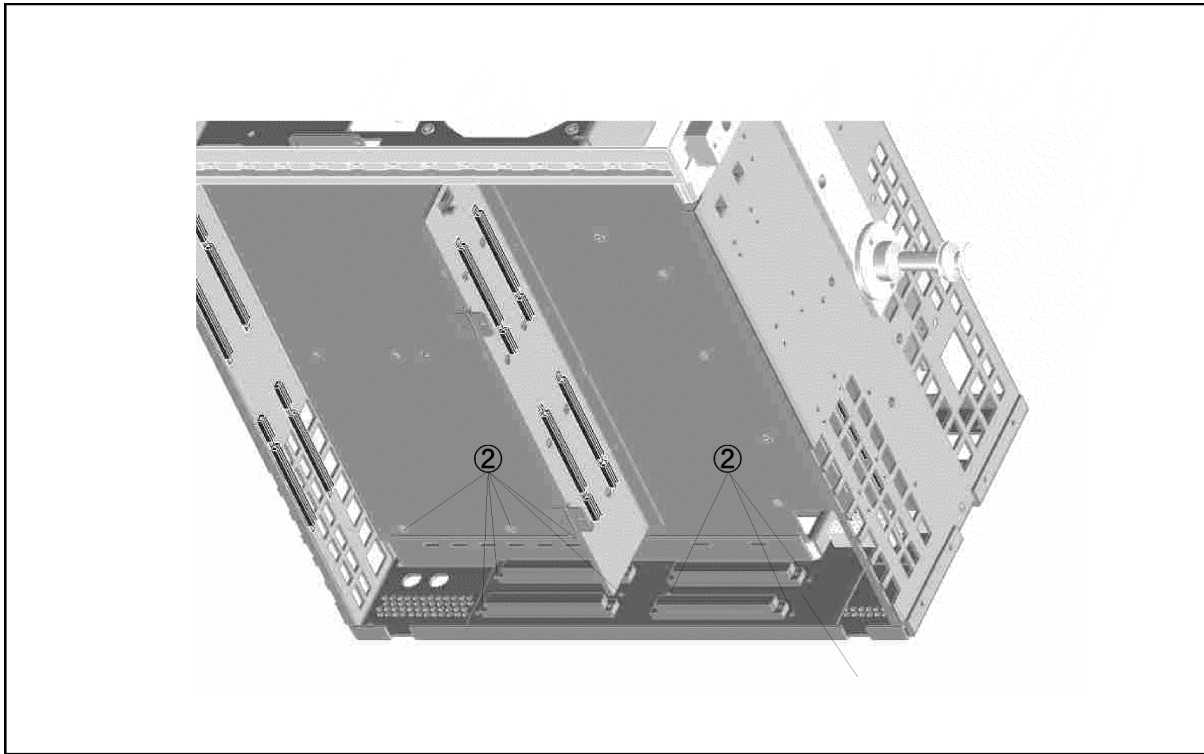

e5070ase291

Table 5-25 Analog Mother Board Assembly

Ref. Desig.	Agilent Part Number	C/D	Qty.	Description
1	E5070-66510	2	1	ANALOG MOTHER BOARD
2	0515-0372	2	9	SCREW-MACH M3.0 x 8 PN T10

Chassis Assembly

Figure 5-27 Chassis Assembly

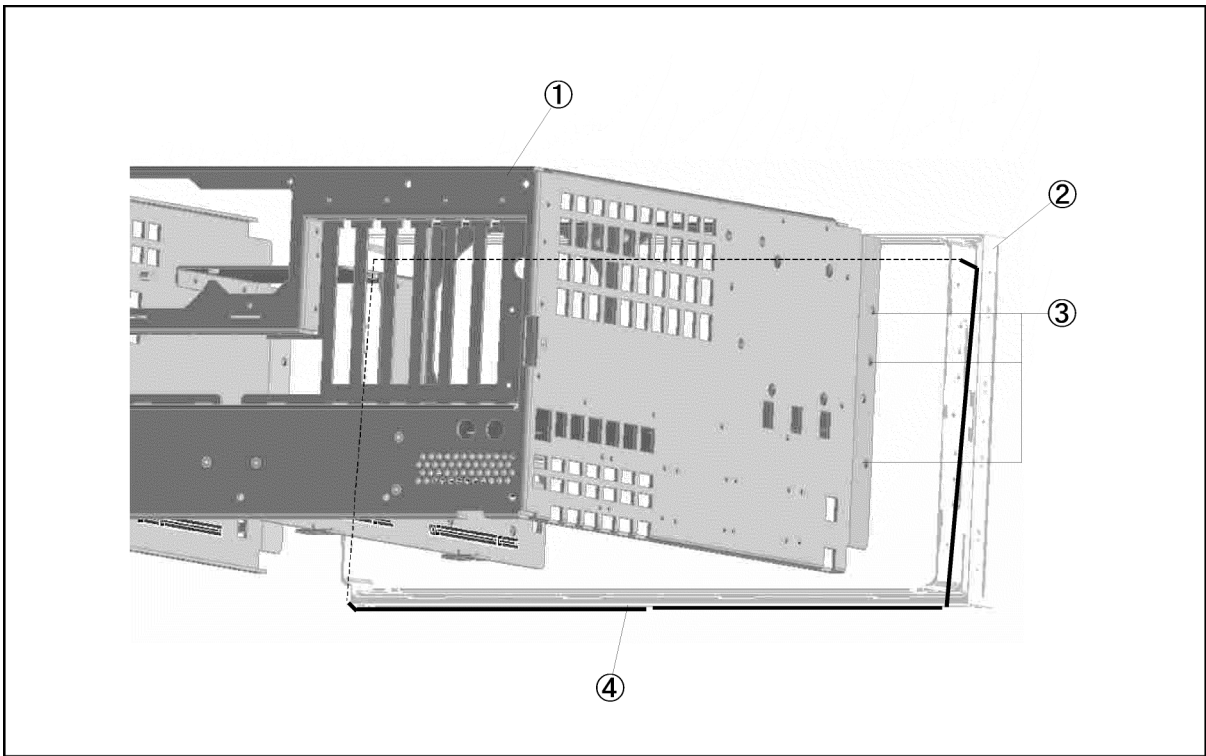

e5070ase292

Table 5-26 Chassis Assembly

Ref. Desig.	Agilent Part Number	C/D	Qty.	Description
1	E5070-60031	0	1	CHASSIS
2	5022-1190	4	1	FRONT FRAME
3	0515-2113	3	6	SCREW-MACH M4.0 x 8 PN T20
4	8160-0641	3	1	GASKET (125 cm)

Keyboard Assembly

Figure 5-28 Keyboard Assembly

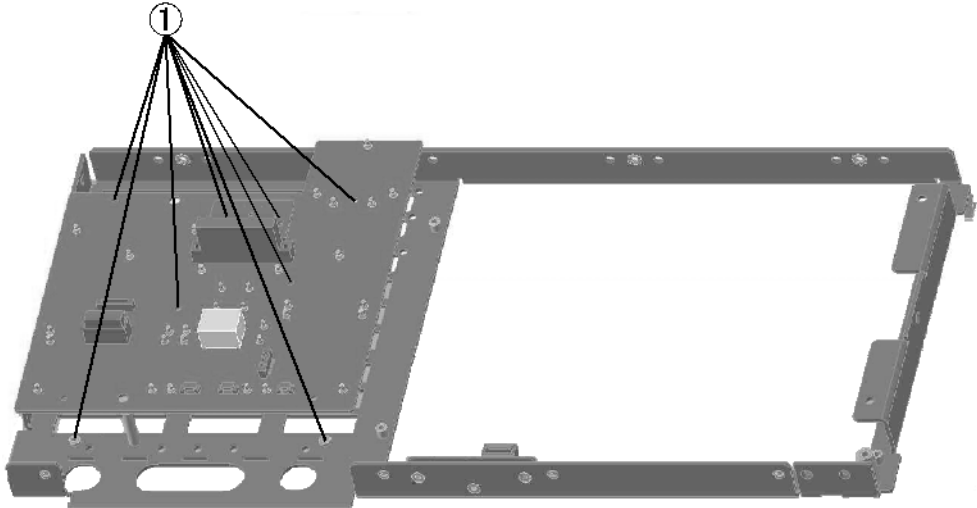

e5070ase064

Table 5-27

Ref. Desig.	Agilent Part Number	C/D	Qty.	Description
1	0515-0430	5	8	SCREW-MACH M3.0 x 6 PN T10

LCD and Inverter Assembly

Figure 5-29 LCD and Inverter Assembly

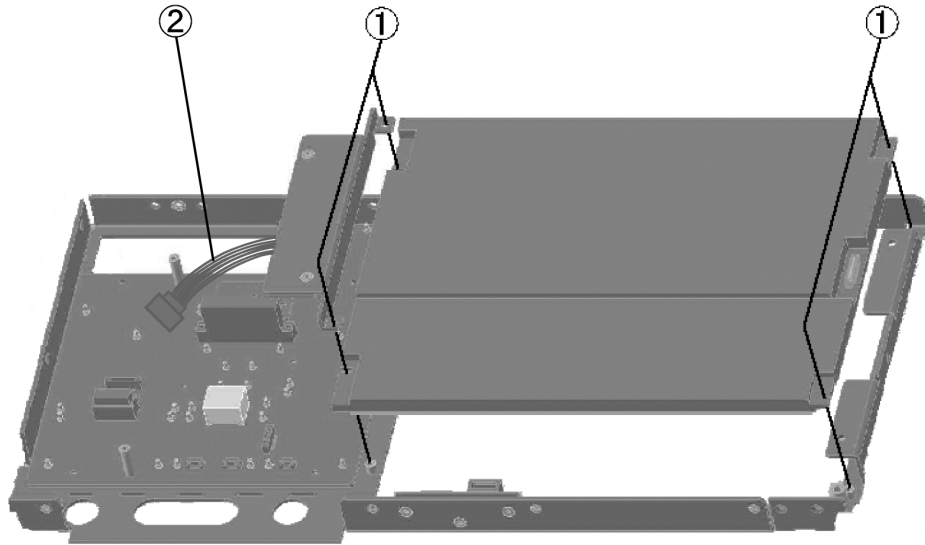

e5070ase295

Table 5-28 LCD and Inverter Assembly

Ref. Desig.	Agilent Part Number	C/D	Qty.	Description
1	0515-1402	5	4	SCREW-MACH M3.0 x 8 PN T15
2	E5070-61627	2	1	WIRE ASSY

Standby Switch Assembly

Figure 5-30 Standby Switch Assembly

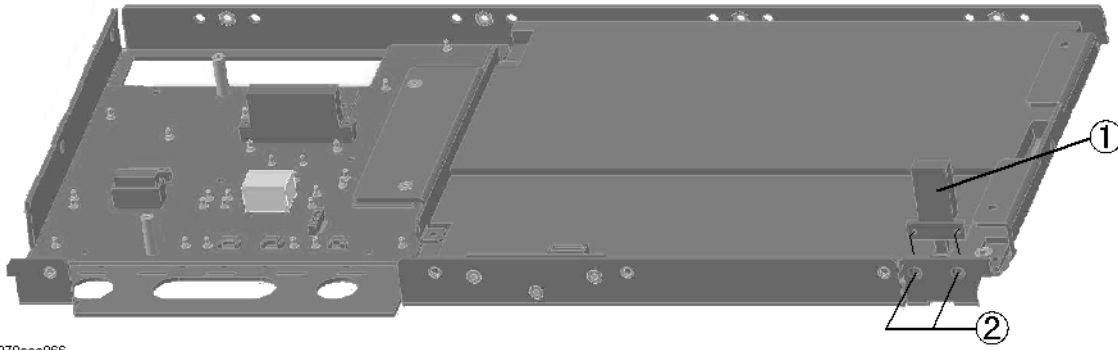

e5070ase066

Table 5-29 Standby Switch Assembly

Ref. Desig.	Agilent Part Number	C/D	Qty.	Description
1	E5070-61901	5	1	WIRE ASSY W/STANDBY SWITCH
2	0515-2028	9	2	SCREW-MACH M2.5 x 6 FL T8

Cover Assembly

Figure 5-31 Cover Assembly

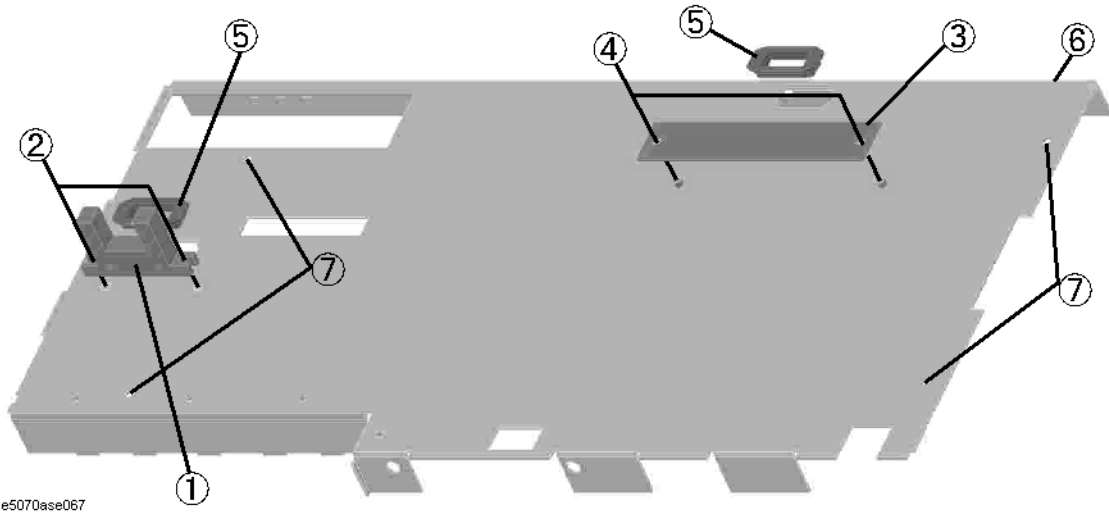

Table 5-30 Cover Assembly

Ref. Desig.	Agilent Part Number	C/D	Qty.	Description
1	E5070-61657	8	1	FLAT CBL ASSY (Opt. 016)
2	0515-0374	4	2	SCREW-MACH M3.0 x 10 PN T10 (Opt. 016)
3	5183-4184	2	1	CNTR TOUCH PANEL (Opt. 016)
4	0515-0430	2	2	SCREW-MACH M3.0 x 6 PN T10 (Opt. 016)
5	1400-3156	4	2	SADDLE EDGE (Opt. 016)
6	E5070-00601	4	1	COVER
7	0515-0430	2	4	SCREW-MACH M3.0 x 6 PN T10

Cover Assembly

Figure 5-32

Cover Assembly

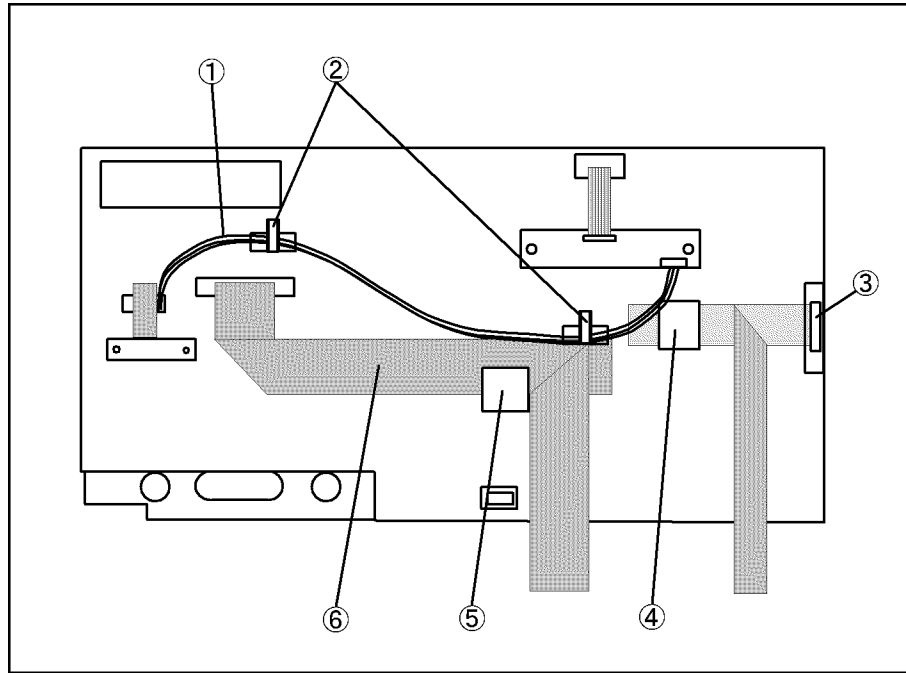

e5070ase068

Table 5-31

Cover Assembly

Ref. Desig.	Agilent Part Number	C/D	Qty.	Description
1	E5070-61628	3	1	WIRE ASSY
2	1400-1334	6	2	CLAMP-CABLE
3	E5070-66531	7	1	LCD ADAPTER
4	1400-0611	0	1	CLAMP-CABLE
5	1400-0611	0	1	CLAMP-CABLE
6	E5070-61622	7	1	FLAT CABLE ASSY

Label on Rear Face

Figure 5-33 Label on Rear Face

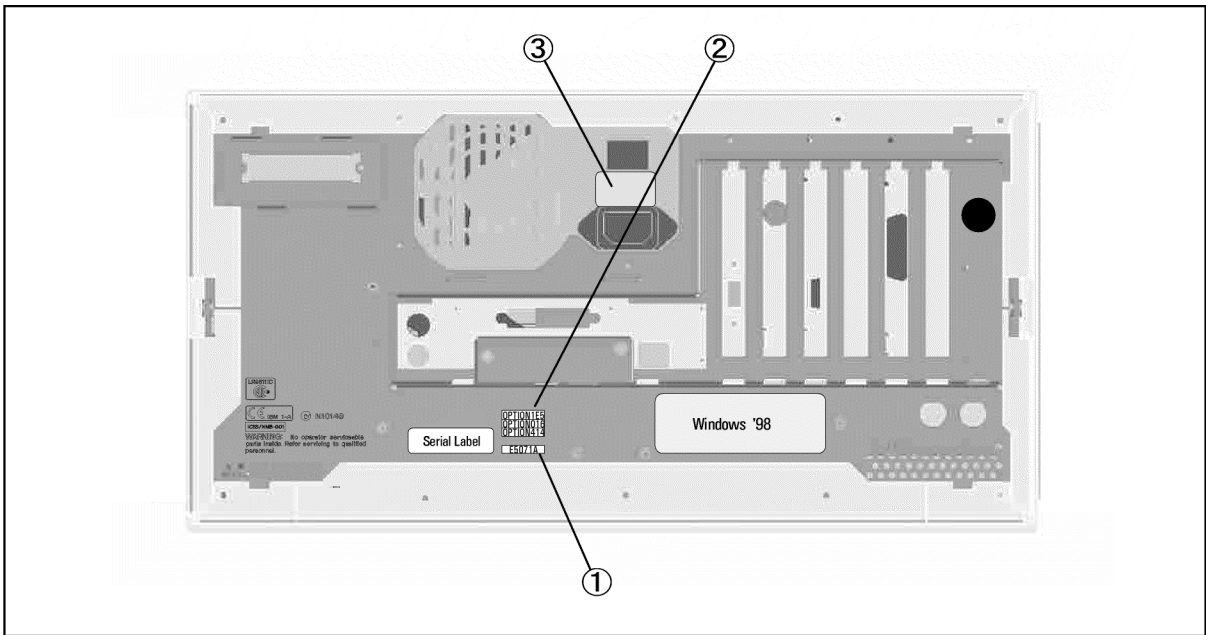

e5070ase293

Table 5-32 Label on Rear Face

Ref. Desig.	Agilent Part Number	C/D	Qty.	Description	
1	E5070-87102	2	1	LABEL (E5070A)	
	E5071-87101	2	1	LABEL (E5071A)	
2	5185-3713	5	1	LABEL (OPTION 213)	
	5185-3714	6	1	LABEL (OPTION 214)	
	5185-3715	7	1	LABEL (OPTION 313)	
	5185-3716	8	1	LABEL (OPTION 314)	
	5185-3717	9	1	LABEL (OPTION 413)	
	5185-3718	0	1	LABEL (OPTION 414)	
	5185-3720	4	1	LABEL (OPTION 016)	
	5185-3722	6	1	LABEL (OPTION 1E5)	
	5080-3939	5	1	LABEL (OPTION 010)	
	3	E5070-87103	3	1	LABEL (NOTE for Switch)

Other Parts

Table 5-33 Other Parts

Agilent Part Number	C/D	Qty.	Description
E5070-900x0 ^{*1}	6	1	USER'S GUIDE
E5070-900x1 ^{*1}	7	1	INSTALLATION AND QUICK START GUIDE
E5070-900x2 ^{*1}	8	1	PROGRAMMER'S GUIDE
E5070-900x3 ^{*1}	9	1	VBA PROGRAMMER'S GUIDE
E5070-901x0 ^{*1}		1	SERVICE MANUAL ^{*2}
E5070-9050x ^{*1}	1	1	CD-ROM (DOCUMENTATION)
1150-7846	6	1	MOUSE
1150-7970	7	1	KEYBOARD

*1. The number indicated by "x" in the part number of each manual, sample program disk, or CD-ROM, 0 for the first edition, is incremented by 1 each time a revision is made. The latest edition comes with the product.

*2. Opt. 0BW only

6 Replacement Procedure

This chapter provides procedure for removing and replacing the major assemblies in the E5070A/E5071A ENA Series Network Analyzer.

Replacing an Assembly

The following steps show the sequence to replace an assembly in a E5070A/E5071A RF Network Analyzer.

1. Identify the faulty group. Refer to Chapter 4, “Troubleshooting.”
2. Order a replacement assembly. Refer to Chapter 5, “Replaceable Parts.”
3. Replace the faulty assembly and determine what adjustments are necessary. Refer to This chapter and Chapter 7, “Post-Repair Procedures.”
4. Perform the necessary adjustments. Refer to Chapter 3, “Adjustment.”
5. Perform the necessary performance tests. Refer to Chapter 2, “Performance Tests.”

WARNING

These servicing instructions are for use by qualified personnel only. To avoid electrical shock, do not perform any servicing unless you are qualified to do so.

WARNING

The opening of covers or removal of parts is likely to expose dangerous voltages. Disconnect the instrument from its power supply.

CAUTION

Many of the assemblies in this instrument are very susceptible to damage from ESD(electrostatic discharge). Perform the following procedures only at a static-safe workstation and wear a grounding strap.

Required Tools

The following tools are required for repair of E5070A/E5071A.

Table 6-1 Required Tools

Assembly	Pozidriv screwdriver	TORX screwdriver				flat edge screwdriver	cutting plier	soldering iron	hex key	open wrench			open torque wrench
	pt size #2*1	T8	T10	T15*2	T20*2					1.5 mm	9/16 in.	5/8 in.	
Outer Cover	√		√	√	√								
Front Panel	√		√	√	√	√							
Mass Storage	√		√	√	√								
FDD	√		√	√	√								
Handler I/O	√		√	√	√								
Power Supply	√		√	√	√		√						
CPU	√		√	√	√	√							
DIMM	√		√	√	√								
Digital Mother Board	√		√	√	√	√	√	√					
Source Board	√		√	√	√						√	√	
Receiver Board	√		√	√	√							√	
Fan & Switch Control Board	√		√	√	√								
Fan	√		√	√	√								
Reference Oven	√		√	√	√								
Switch	√		√	√	√	√							√
Attenuator	√		√	√	√	√							√
Analog Motherboard	√		√	√	√	√					√	√	
Analog Interface Board	√		√	√	√								
Display Board	√		√	√	√	√							
GPIB Board	√		√	√	√								
Front Keyboard	√		√	√	√	√			√				
Inverter	√	√	√	√	√	√							
LCD	√		√	√	√	√							
LCD Backlight	√		√	√	√	√							
N connector	√		√	√	√	√				√		√	

*1. where Pozidriv screws are in use

*2. where TORX screws are in use

Outer Cover Removal

Tools Required

- Pozidriv screwdriver, pt size #2 (medium) (where Pozidriv screws are in use)
- TORX screwdriver, T10, (T15, T20 where TORX screws are in use)

Procedure

Refer to Figure 6-1 for this procedure.

- Step 1.** Disconnect the power cable from the E5070A/E5071A.
- Step 2.** Put a plastic cover (p/n 5959-8096, item 1) on the front panel of the analyzer and place the analyzer on flat table with its front panel down.
- Step 3.** Remove the four Pozidriv or TORX T20 screws (item 2) fastening the side strap handles.
- Step 4.** Remove the four Pozidriv or TORX T15 screws (item 3) fastening the four rear foot
- Step 5.** Remove the six Pozidriv or TORX T15 screws (item 4) fastening the cover from the rear side.
- Step 6.** Remove the four TORX T10 screws (item 6) from the bottom.
- Step 7.** Remove the four bottom feet (item 7).
- Step 8.** Slide up the outer cover and remove it carefully.

Figure 6-1 Outer Cover Removal

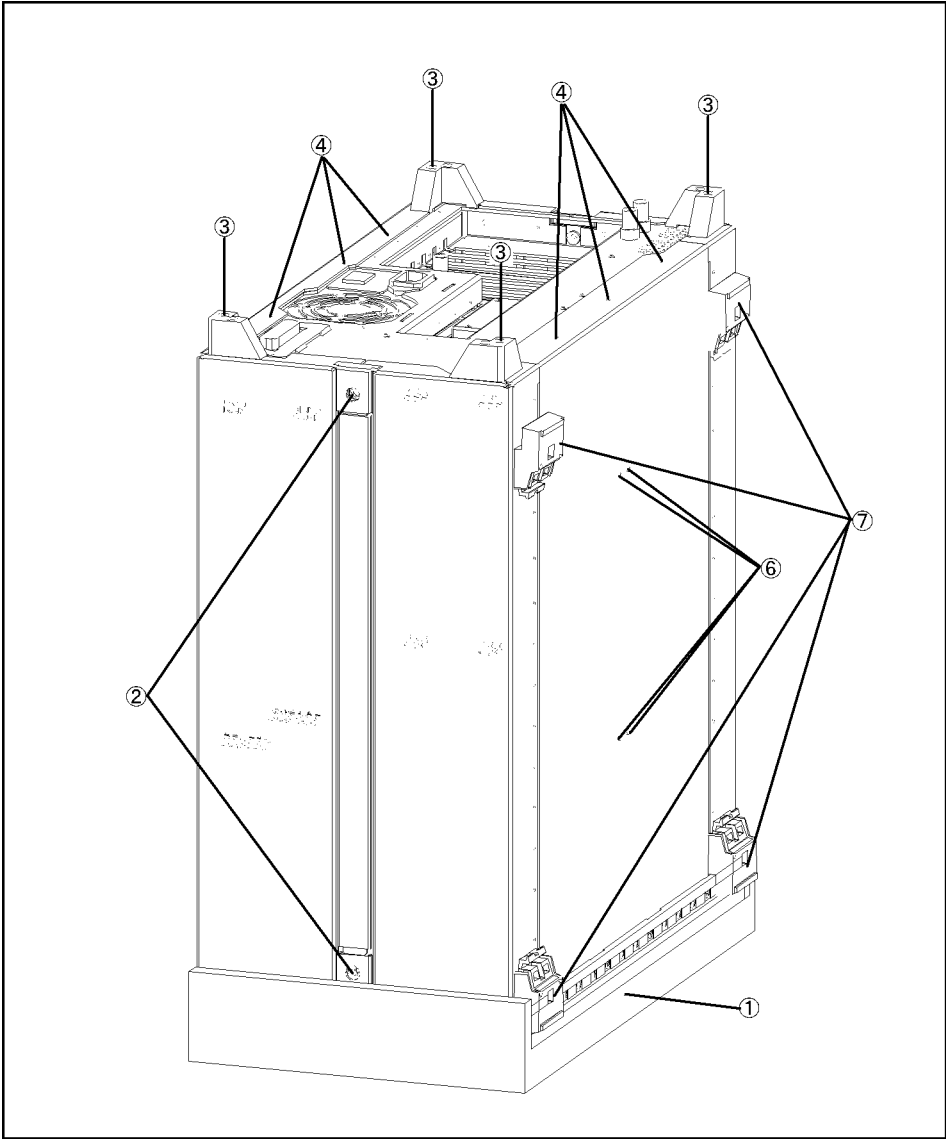

e5070ase296

Front Panel Removal

Tools required

- Pozidriv screwdriver, pt size #2 (medium) (where Pozidriv screws are in use)
- TORX screwdriver, T15 (where TORX screws are in use)
- flat edge screwdriver

Procedure

Refer to Figure 6-2 for this procedure.

- Step 1.** Remove the top trim (item 1) using a flat edge driver.
- Step 2.** Remove the eight Pozidriv or TORX T15 screws (item 2) fastening front panel.
- Step 3.** Gradually push the front panel assembly towards the outside.
- Step 4.** Release the mylar cable (item 3) from the cable clamp (clamp 4).
- Step 5.** Disconnect the three cables (item 5, 6 and 7) from the front panel.

NOTE Keep the mylar cable connected.

Figure 6-2 Front Panel Removal

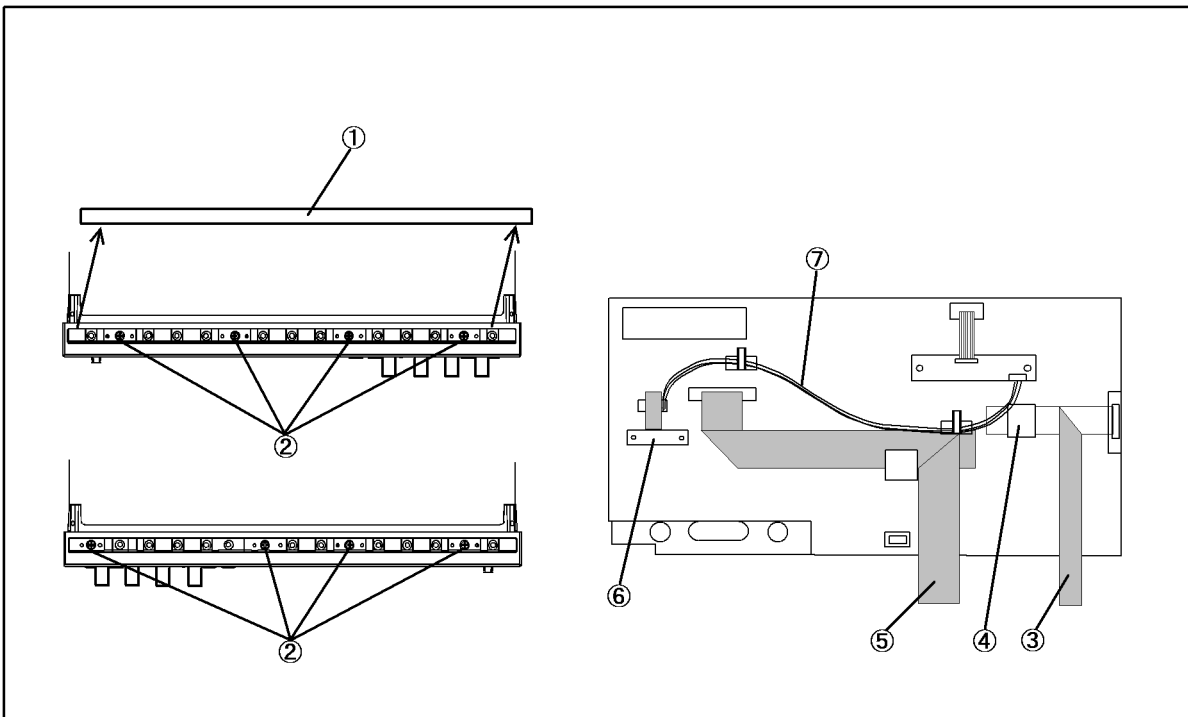

e5070ase231

A27 Mass Storage Disk Drive Replacement

Tools Required

- Pozidriv screwdriver, pt size #2 (medium) (where Pozidriv screws are in use)
- TORX screwdriver, T10, (T15, T20 where TORX screws are in use)

Removal Procedure

Refer to Figure 6-3 for this procedure.

- Step 1.** Remove the outer cover as described in “Outer Cover Removal” on page 282.
- Step 2.** Remove the four TORX T10 screws (item 1) fastening the A27 mass storage disk drive.
- Step 3.** Lift the mass storage disk drive.

Figure 6-3 A27 Mass Storage Disk Drive Removal

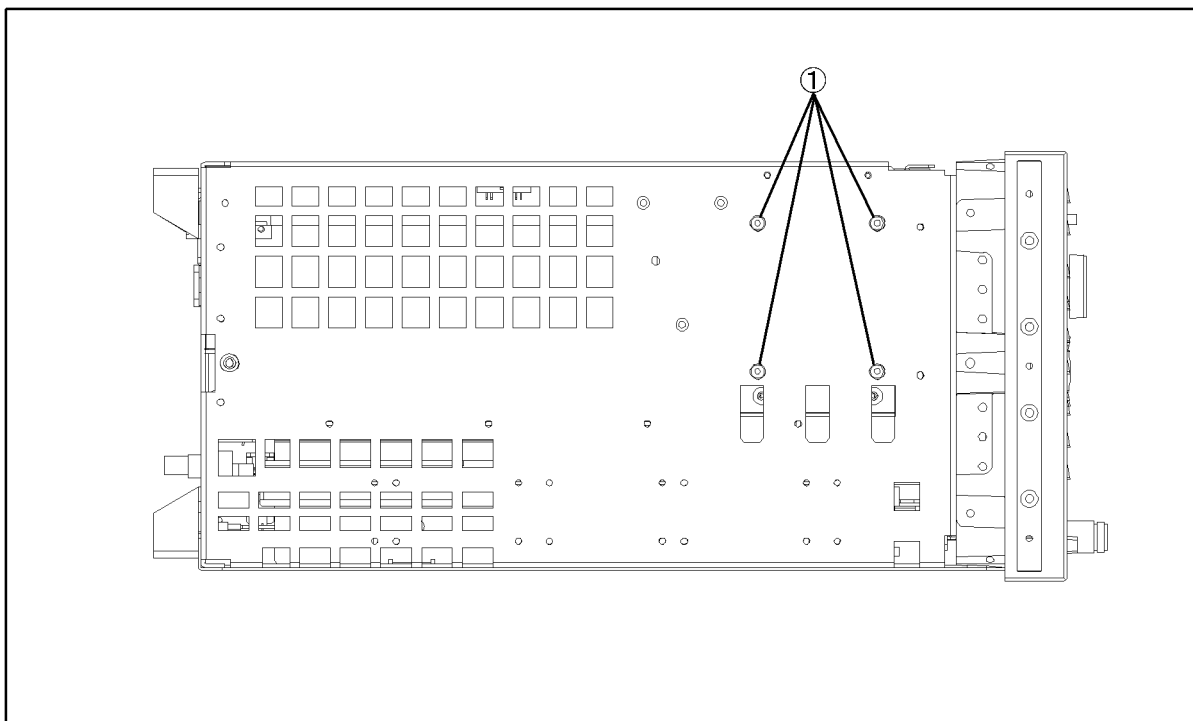

e5070ase226

Replacement Procedure

- Step 1.** Reverse the order of the removal procedure.

Restore Backup Files onto the New Mass Storage Disk Drive

The Backup files is stored in the flash ROM on the analog interface board. The file must be

Replacement Procedure

A27 Mass Storage Disk Drive Replacement

restored in the new mass storage disk drive with the adjustment program. For detail of the adjustment program, refer to Chapter 3, “Adjustment,” on page 133.

- Step 1.** Run the adjustment program.
- Step 2.** Input the GPIB address of the E5070A/E5071A.
- Step 3.** Input the serial number of the E5070A/E5071A.
- Step 4.** Choose *Spot Adjustment*.
- Step 5.** Choose *HDD*.

Calibration of the Touch Screen

When you have replaced the HDD on a E5070A/E5071A equipped with an Option 016 touch screen, you have to calibrate the touch screen. Follow the procedure described below to calibrate the touch screen.

- Step 1.** Press **System**.
- Step 2.** Press **Service Menu**.
- Step 3.** Press **Test Menu**.
- Step 4.** Press **Adjust Touch Screen**.

The touch screen calibration screen (Figure 6-4) appears.

Figure 6-4

Touch Panel Calibration Screen

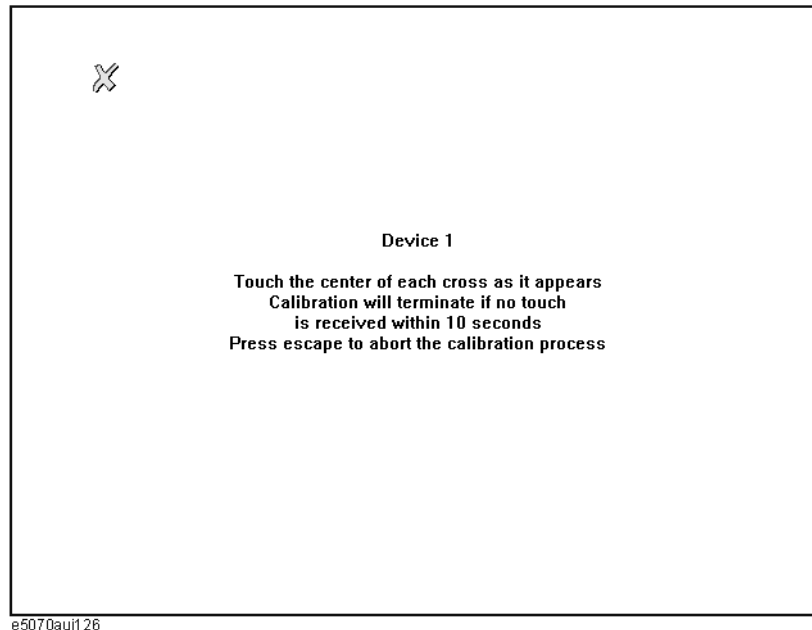

- Step 5.** Touch the x mark on the upper left with your finger. The mark x appears also on the lower left, upper right, and lower right. Touch the x marks in that order with your finger.

Touching the four locations described above with your finger automatically concludes the touch screen calibration.

NOTE

With no operation on the touch screen calibration screen for a preset time, it automatically closes and the previous measurement screen reappears.

A28 FDD (Floppy Disk Drive) Removal

Tools Required

- Pozidriv screwdriver, pt size #2 (medium) (where Pozidriv screws are in use)
- TORX screwdriver, T10, (T15, T20 where TORX screws are in use)

Procedure

Refer to Figure 6-5 for this procedure.

- Step 1.** Remove the outer cover as described in “Outer Cover Removal” on page 282.
- Step 2.** Disconnect the cable (item 1) connected from the power supply.
- Step 3.** Remove three TORX T10 screws (item 2).
- Step 4.** Slide the A28 FDD assembly backward.

CAUTION Slide the assembly slowly to prevent tension from cables

- Step 5.** Disconnect the flat cable (item 3) from the FDD.
- Step 6.** Remove the four TORX T10 screws (item 4) fastening the FDD to the mount.
- Step 7.** Remove the two TORX T10 screws (item 5) fastening the plate.

Figure 6-5 A28 FDD Removal

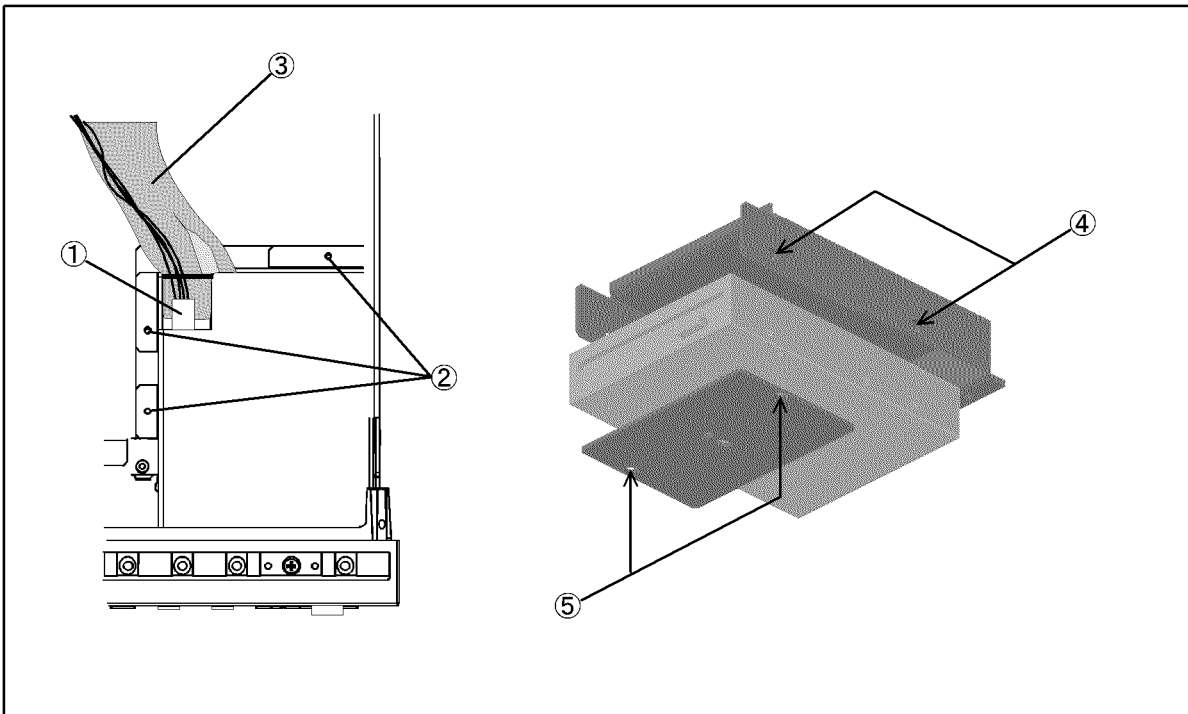

e5070ase227

A23 Handler I/O Board Removal

Tools Required

- Pozidriv screwdriver, pt size #2 (medium) (where Pozidriv screws are in use)
- TORX screwdriver, T10, (T15, T20 where TORX screws are in use)

Procedure

Refer to Figure 6-6 for this procedure.

- Step 1.** Remove the outer cover as described in “Outer Cover Removal” on page 282.
- Step 2.** Disconnect the flat cable (item 1) from the A23 handler I/O board.
- Step 3.** Remove the two TORX T10 screws (item 2) fastening the A23 handler I/O board.
- Step 4.** Slide the A23 handler I/O board toward backward.

Figure 6-6 A23 Handler I/O Board Removal

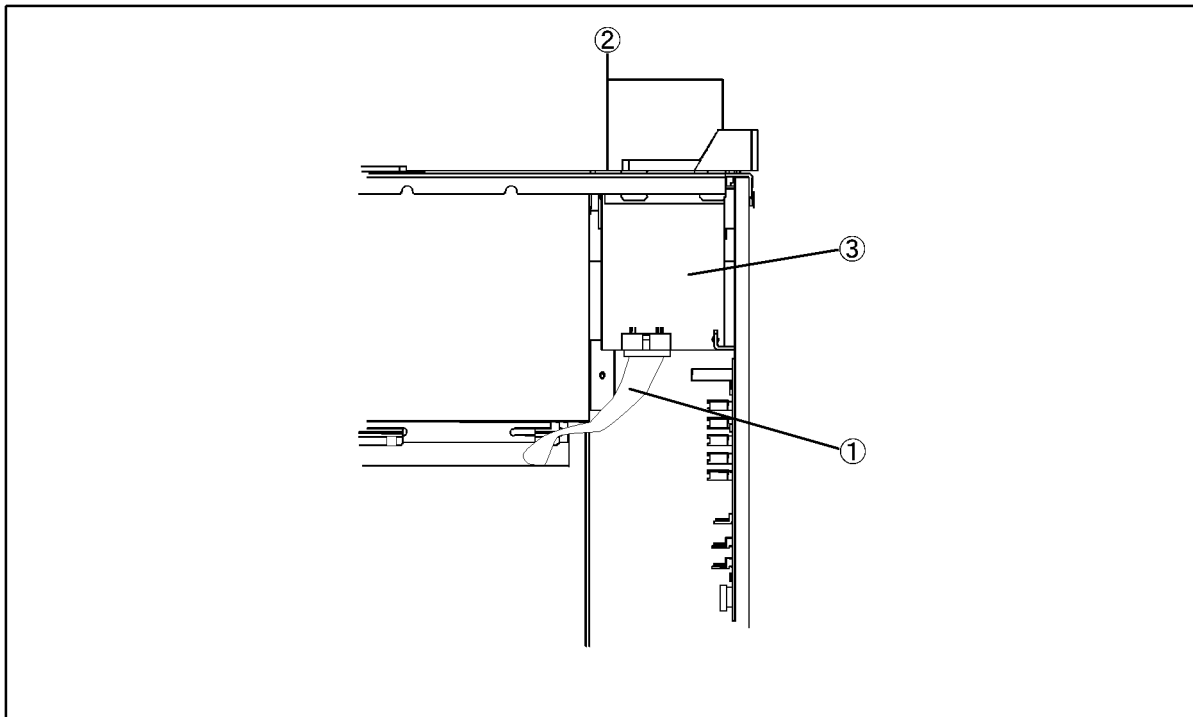

e5070ase232

A50 ATX Power Supply Assembly Removal

Tools Required

- Pozidriv screwdriver, pt size #2 (medium) (where Pozidriv screws are in use)
- TORX screwdriver, T10, (T15, T20 where TORX screws are in use)
- cutting plier or scissors

Procedure

Refer to Figure 6-7 for this procedure.

- Step 1.** Remove the outer cover as described in “Outer Cover Removal” on page 282.
- Step 2.** Remove the handler I/O board as described in “A23 Handler I/O Board Removal” on page 289.
- Step 3.** Disconnect two flat cables (item 1 and 2) from the analog mother board.
- Step 4.** Disconnect the power supply cables (item 3, 4 and 5).
- Step 5.** Release all cables clamped on the power supply holder.
- Step 6.** Remove the two TORX T10 screws (item 6) fastening the power supply holder.
- Step 7.** Remove the two TORX T10 (item 7) from the rear panel.
- Step 8.** Lift the A50 ATX power supply assembly toward front side with the mount.
- Step 9.** Cut the cable tie (item 8) if you replace the power supply.

CAUTION Don't forget to clamp cables after replacement.

Figure 6-7 A50 ATX Power Supply Assembly Removal

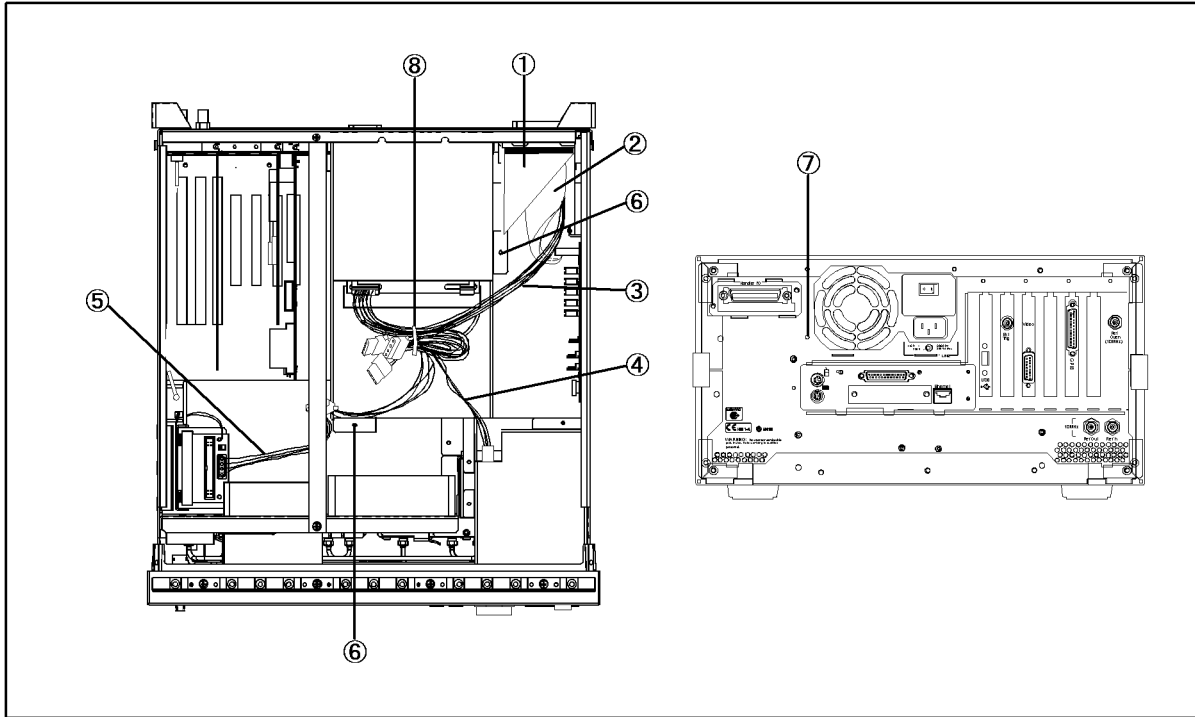

e5070ase233

CPU Removal

There is a CPU on the A20 digital motherboard.

Tools Required

- Pozidriv screwdriver, pt size #2 (medium) (where Pozidriv screws are in use)
- TORX screwdriver, T10, (T15, T20 where TORX screws are in use)
- Flat edge screwdriver

Procedure

NOTE

Always handle the CPU by the edges, never touch the pins.

Refer to Figure 6-8 for this procedure.

- Step 1.** Remove the outer cover as described in “Outer Cover Removal” on page 282
- Step 2.** Remove the A50 ATX power supply as described in “A50 ATX Power Supply Assembly Removal” on page 290
- Step 3.** Disconnect the CPU fan cable (item 1) from the A20 digital motherboard.
- Step 4.** Keep pushing the heatsink clip (item 2), then release it from the CPU socket tabs using the flat edge screwdriver.
- Step 5.** Pull the CPU socket release lever (item 3) laterally away from the CPU socket to disengage the level from the locking tab. Then rotate the lever upward to release the CPU from the CPU socket.
- Step 6.** Lift the CPU out of the socket.
- Step 7.** To replace the CPU, reverse the CPU removal procedure. Install the CPU so that all pins on the CPU aligns with the holes of the PGA370 socket.

Figure 6-8 CPU Removal

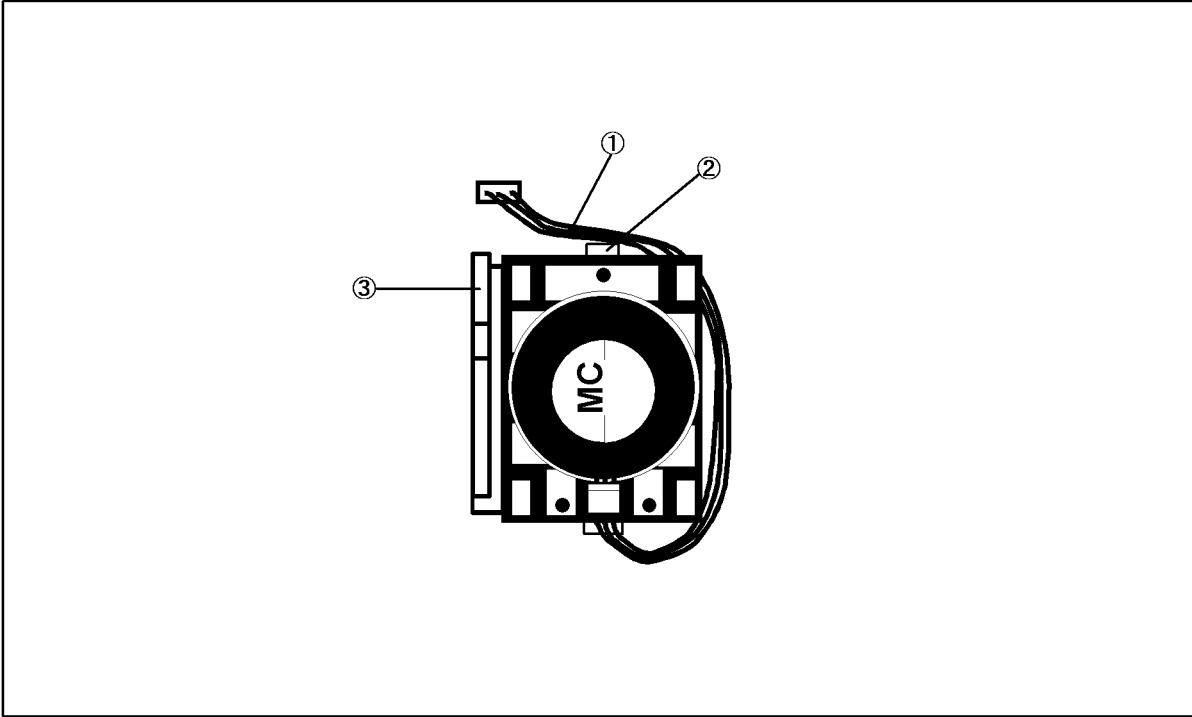

e5070ase234

DIMM Module Removal

There are two DIMM128MB memory module on the A20 digital motherboard.

Tools Required

- Pozidriv screwdriver, pt size #2 (medium) (where Pozidriv screws are in use)
- TORX screwdriver, T10, (T15, T20 where TORX screws are in use)

Procedure

- Step 1.** Remove the outer cover as described in “Outer Cover Removal” on page 282.
- Step 2.** Remove the A50 ATX power supply as described in “A50 ATX Power Supply Assembly Removal” on page 290.
- Step 3.** There are three DIMM sockets on the A20 digital mother board. A DIMM memory modules is installed at each socket.
- Step 4.** Unlatch the two clips and remove the DIMM memory.
- Step 5.** To replace the DIMM memory, reverse the above procedure. Install the DIMM memory in the socket and latch the clips.

A20 Digital Motherboard Replacement

Tools Required

- Pozidriv screwdriver, pt size #2 (medium) (where Pozidriv screws are in use)
- TORX screwdriver, T10, (T15, T20 where TORX screws are in use)
- Flat edge screwdriver
- Cutting plier or scissors
- Soldering iron

Removal Procedure

Refer to Figure 6-9 for this procedure.

- Step 1.** Remove the mouse, the external keyboard and the parallel printer cable if they are connected to the rear panel.
- Step 2.** Remove the outer cover as described in “Outer Cover Removal” on page 282
- Step 3.** Remove the following assemblies.
 - A23 Handler I/O board (refer to “A23 Handler I/O Board Removal” on page 289.)
 - A21 Analog Interface board (refer to “A21 Analog Interface Board Removal” on page 311.)
 - A24 GPIB board (refer to “A24 GPIB Card Replacement” on page 314.)
 - A26 LCD Interface Card (refer to “A26 LCD Interface Card Removal” on page 312.)
 - A50 ATX Power Supply (refer to “A50 ATX Power Supply Assembly Removal” on page 290.)
- Step 4.** Disconnect the following cables.
 - Connected from the A28 FDD (item 1).
 - Connected from the mass storage disk assembly (item 2)
 - Connected from the A21 Analog Interface Board (item 3).
 - Connected to the A32 USB connector (item 4 and 5)
- Step 5.** Remove two screws fastening the plate (item 6).
- Step 6.** Remove two screws fastening the cover (item 7), then remove the cover.
- Step 7.** Disconnect the cable from the connector on the rear panel if the option 016 is installed.
- Step 8.** Remove seven screws (item 8) fastening the digital motherboard.
- Step 9.** Lift the digital motherboard.

Replacement Procedure A20 Digital Motherboard Replacement

Figure 6-9 A20 Digital Motherboard Removal

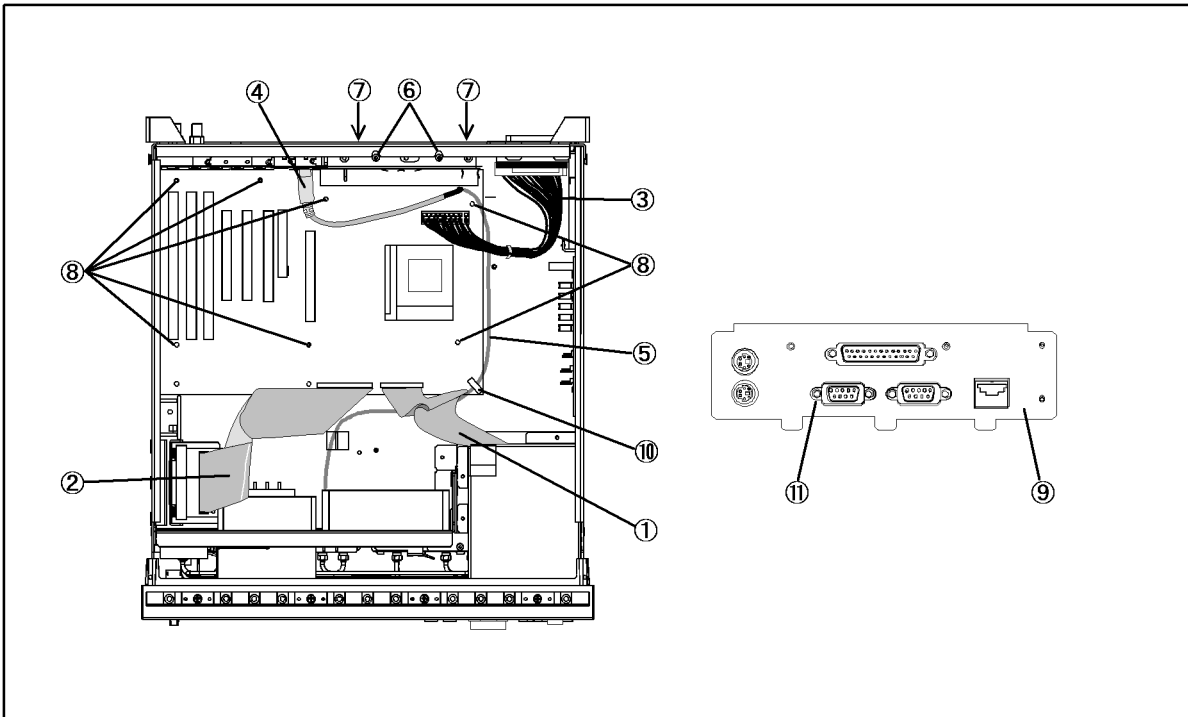

e5070ase236

Replacement Procedure

Refer to Figure 6-9 for this procedure.

- Step 1.** Remove the CPU and CPU fan as described in “CPU Removal” on page 292.
- Step 2.** Remove the DIMM modules as described in “DIMM Module Removal” on page 294.
- Step 3.** Disassemble the guide plate (item 9) from rear side of the mother board.
- Step 4.** Cut the cable tie (item 10) holding the USB cable to the digital motherboard.
- Step 5.** Unsolder the USB cables.
- Step 6.** Solder the USB cables to the new board.
- Step 7.** Hold the USB cable to the new board by a cable tie.
- Step 8.** Remove a screw (item 11) from a serial connector.
- Step 9.** Place the guide plate to the rear side of the new board.
- Step 10.** Install the new board by the reverse procedure of removal.

A1 Source Board Removal

Tools Required

- Pozidriv screwdriver, pt size #2 (medium) (where Pozidriv screws are in use)
- TORX screwdriver, T10, (T15, T20 where TORX screws are in use)
- Flat edge screwdriver
- Open-end wrench, 5/8 inch
- Open-end torque wrench, 5/16 inch (set to 10 in-lb) (for reconnecting SMA connector)

Removal Procedure

Refer to Figure 6-10 for this procedure.

- Step 1.** Remove the front panel as described in “Front Panel Removal” on page 284.
- Step 2.** Remove the two 5/8 inch nuts (item 1) fastening the BNC connector on the rear panel when the source is removed.
- Step 3.** Disconnect the all semi-rigid cables and the termination connected to the boards referring to the figures as shown in Table 6-2.

NOTE The label on the semi-rigid cable show the last two digits of the part number.

Table 6-2

Reference Figure

Option	Figure
213	Figure 5-9 on page 248
214	Figure 5-10 on page 249
313	Figure 5-11 on page 250
314	Figure 5-12 on page 252
413	Figure 5-13 on page 254
414	Figure 5-14 on page 256

- Step 4.** Remove the two TORX T10 screws fastening the extractor. (item 2)
- Step 5.** Slide the A1 source board using the extractor.

NOTE Fasten the semi rigid cable using a torque wrench for replacement.

Replacement Procedure
A1 Source Board Removal

Figure 6-10 **A1 Source Board Removal**

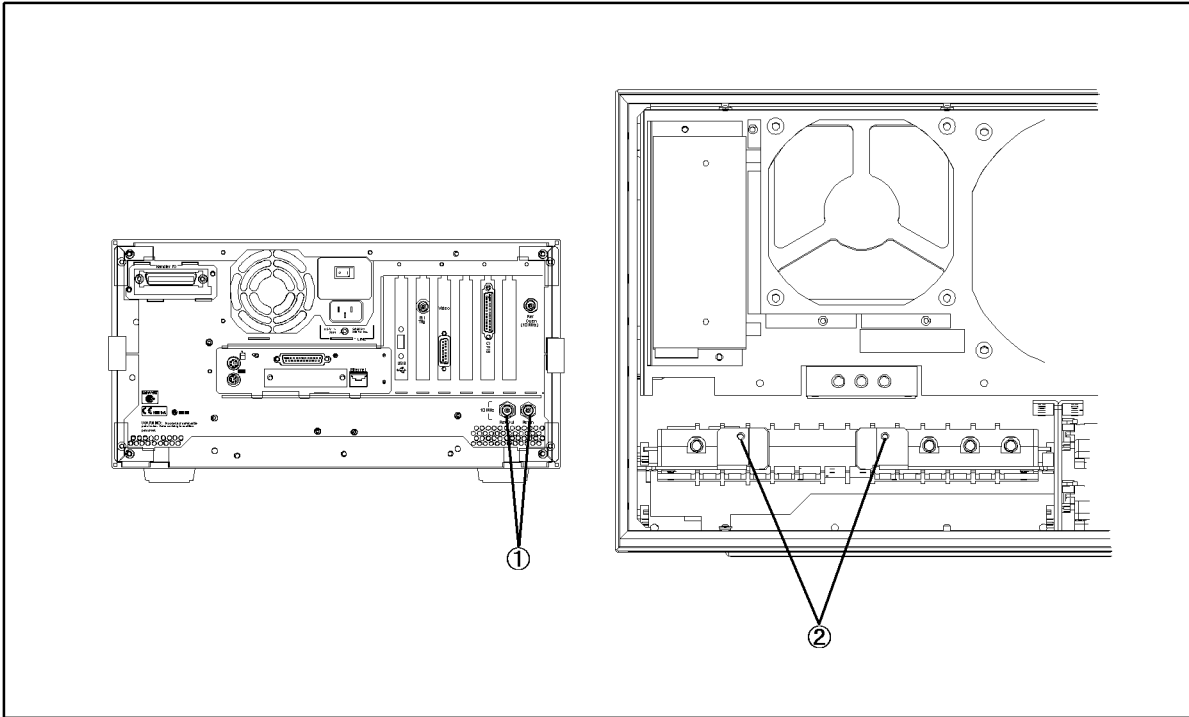

e5070ase237

A2 Receiver Board Removal

Tools Required

- Pozidriv screwdriver, pt size #2 (medium) (where Pozidriv screws are in use)
- TORX screwdriver, T10, (T15, T20 where TORX screws are in use)
- Flat edge screwdriver
- Open-end torque wrench, 9/16 inch
- Open-end torque wrench, 5/16 inch (set to 10 in-lb) (for reconnecting SMA connector)

Removal Procedure

Refer to Figure 6-11 for this procedure.

- Step 1.** Remove the front panel as described in “Front Panel Removal” on page 284.
- Step 2.** Remove the three Pozidriv screws fastening the N-connectors mount from the outside.
- Step 3.** Disconnect the semi-rigid cables and the termination from the receiver module as shown in Table 6-3.

NOTE The label on the semi-rigid cable show the last two digits of the part number.

Table 6-3

Reference Figure

Option	Figure
213	Figure 5-9 on page 248
214	Figure 5-10 on page 249
313	Figure 5-11 on page 250
314	Figure 5-12 on page 252
413	Figure 5-13 on page 254
414	Figure 5-14 on page 256

- Step 4.** Remove the all TORX T10 screws fastening the extractor . (item 1)
- Step 5.** Slide the receiver module using the extractor.

NOTE Slide the two board at once if two A2 receiver boards are slotted.

NOTE Fasten the semi rigid cable using a torque wrench for replacement.

Replacement Procedure
A2 Receiver Board Removal

Figure 6-11 **A2 Receiver Removal**

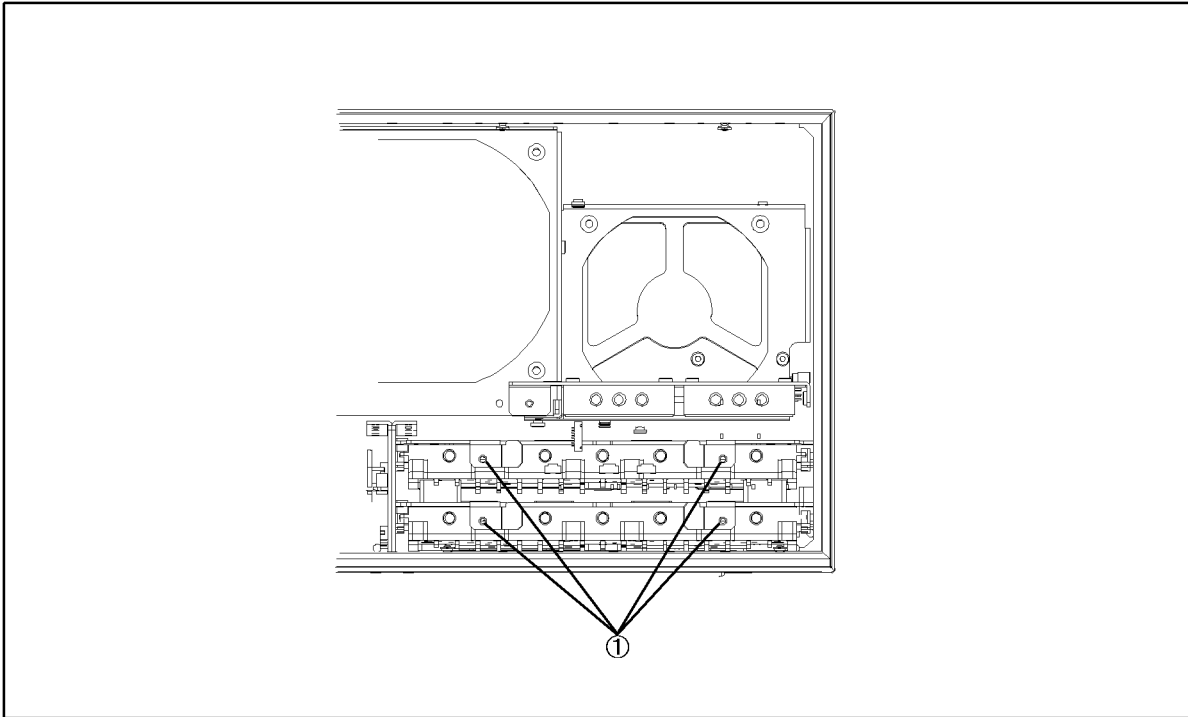

e5070ase238

Module Disassemble Procedure

Skip this procedure if the option 213 or 214 is installed.

Refer to Figure 6-12 for this procedure.

- Step 1.** Remove the eight TORX T10 screws (item 1) fastening the A2 receiver boards.
- Step 2.** Separate the two A2 receiver boards.

Figure 6-12 Receiver Disassemble

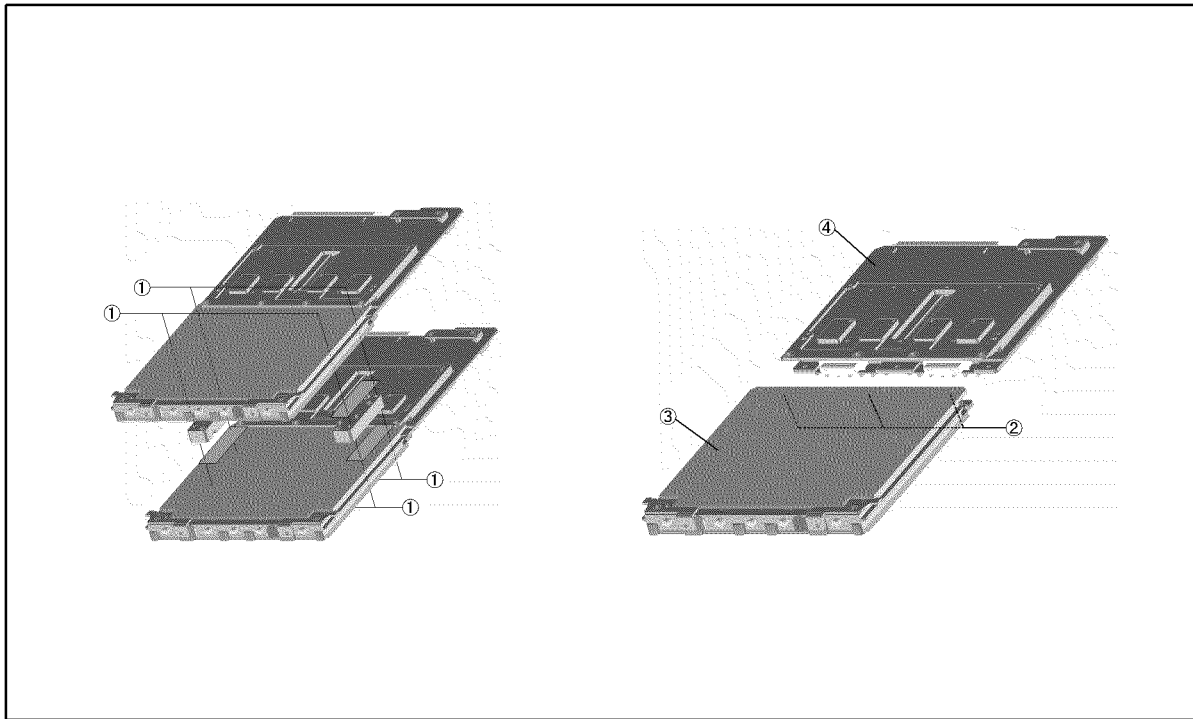

e5070ase222

Board Disassemble Procedure

Refer to Figure 6-12 for this procedure.

- Step 1.** Remove the three TORX T15 screws (item 1) fastening the A14 Receiver-RF board (item 2) and the A17 Receiver-IF board (item 3).
- Step 2.** Separate the two boards.

B1 Fan & A6 Switch Control Board Removal

Tools Required

- Pozidriv screwdriver, pt size #2 (medium) (where Pozidriv screws are in use)
- TORX screwdriver, T10, (T15, T20 where TORX screws are in use)

Procedure

Refer to Figure 6-13 for this procedure.

- Step 1.** Remove the outer cover as described in “Outer Cover Removal” on page 282.
- Step 2.** Mark the switch cables to show where each cable is connected. (refer to Figure 6-13)
- Step 3.** Disconnect the all cables from the board.
- Step 4.** Remove three screws (item 3 in Figure 6-13) fastening the board from the side.
- Step 5.** Remove the board.

NOTE

Connect as Figure 6-13 if you forgot marking in step 2. To confirm which switch each cable is connected to, remove the front panel as described in “Front Panel Removal” on page 284

Figure 6-13 B1 Fan & A6 Switch Control Board Removal

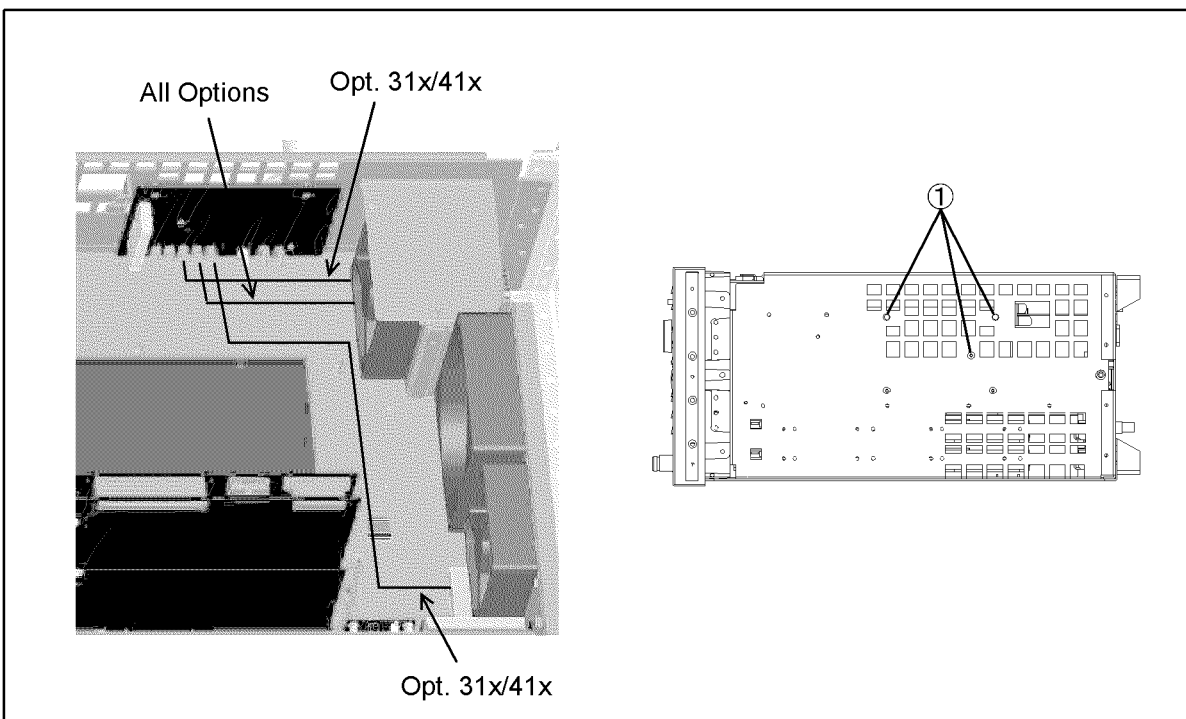

e5070ase223

B1 Fan Removal

Tools Required

- Pozidriv screwdriver, pt size #2 (medium) (where Pozidriv screws are in use)
- TORX screwdriver, T10 and T20, (T15 where TORX screws are in use)

Procedure

- Step 1.** Remove the outer cover as described in “Outer Cover Removal” on page 282.
- Step 2.** Remove the power supply as described in “A50 ATX Power Supply Assembly Removal” on page 290.
- Step 3.** Disconnect the fan cable from the fan & switch control board.
- Step 4.** Remove parts and cables which may block operation.
- Step 5.** Remove the four screws fastening the fan.

NOTE

The center fan is fastened by the pozidriv screws. The other fans are fastened by the TORX T20 screws.

Fasten the fan in the direction as shown in Figure 6-14

Figure 6-14 The direction of the fan

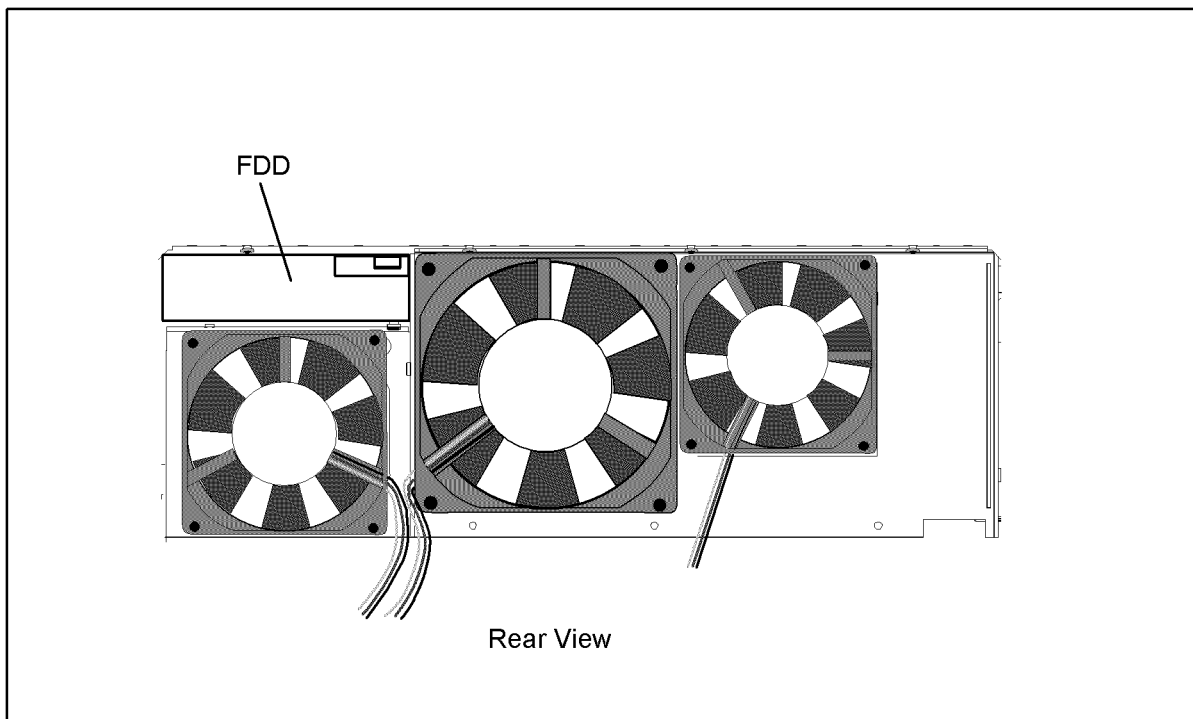

e5070ase224

A5 Crystal Oven Board (Opt.1E5) Removal

Tools Required

- Pozidriv screwdriver, pt size #2 (medium) (where Pozidriv screws are in use)
- TORX screwdriver, T10, (T15, T20 where TORX screws are in use)

Procedure

Refer to Figure 6-15 for this procedure.

- Step 1.** Remove the outer cover as described in “Outer Cover Removal” on page 282.
- Step 2.** Remove the two cables (item 1 and 2) connected to the A5 crystal oven board.
- Step 3.** Remove three TORX T10 screws (item 3) fastening the A5 crystal oven board from the outside.

Figure 6-15 A5 Crystal Oven Board Removal

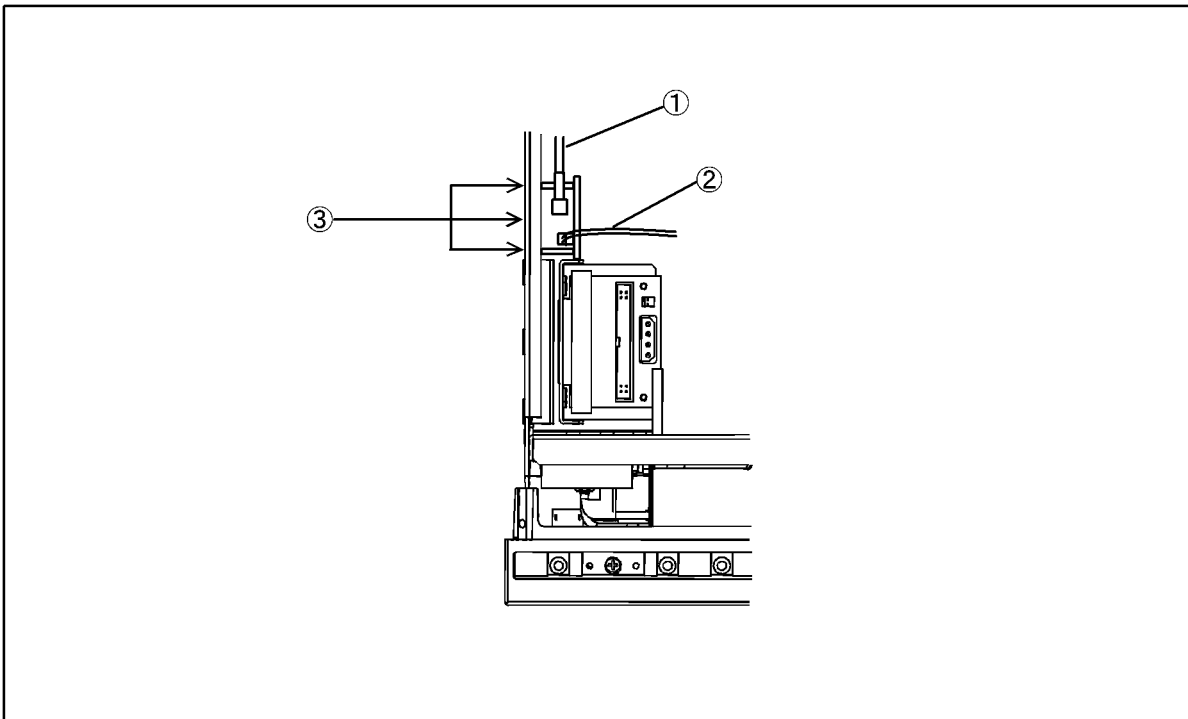

e5070ase225

A8 RF Switch Replacement

Tools Required

- Pozidriv screwdriver, pt size #2 (medium) (where Pozidriv screws are in use)
- TORX screwdriver, T10, (T15, T20 where TORX screws are in use)
- Flat edge screwdriver
- Open-end torque wrench, 5/16 inch (set to 10 in-lb) (for reconnecting SMA connector)

A8 RF Switch (source board side)

Removal Procedure

Refer to Figure 6-16 for this procedure.

- Step 1.** Remove the front panel as described in “Front Panel Removal” on page 284.
- Step 2.** Remove the three TORX T10 screws (item 1) fastening the fan plate.
- Step 3.** Disconnect the all semi-rigid cables from the switch on the left side. (refer to the figure as shown in Table 6-4)

NOTE

The label on the semi-rigid cable show the last two digits of the part number.

Table 6-4

Reference Figure

Option	Figure
213	Figure 5-9 on page 248
214	Figure 5-10 on page 249
313	Figure 5-11 on page 250
314	Figure 5-12 on page 252
413	Figure 5-13 on page 254
414	Figure 5-14 on page 256

- Step 4.** Disconnect the switch cable from the switch.
- Step 5.** Remove the two TORX T10 screws fastening the switch. (item 2)

Replacement Procedure
A8 RF Switch Replacement

Figure 6-16 A8 RF Switch (source board side) Replacement

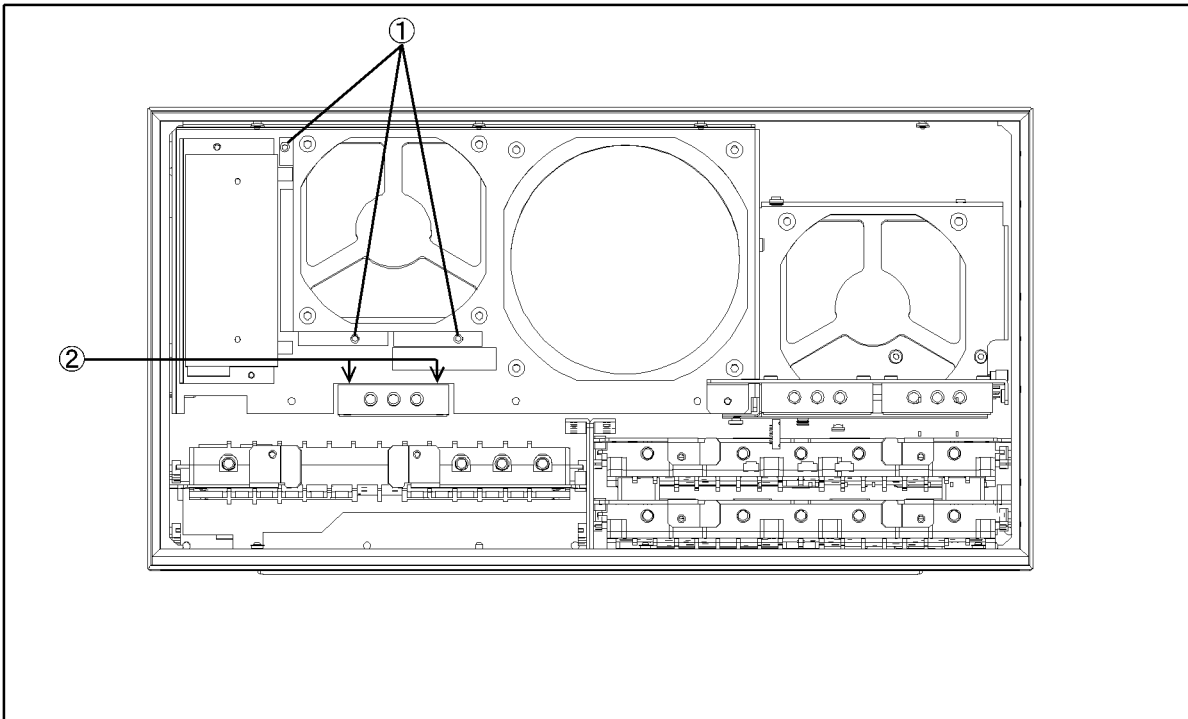

e5070ase228

Replacement Procedure

Step 1. Replace the switch by inverse procedure of removal.

NOTE Fasten the semi-rigid cable using a torque wrench for replacement.

A8 RF Switch (receiver board side)

Removal Procedure

Refer to Figure 6-17 for this procedure.

- Step 1.** Remove the outer cover as described in “Outer Cover Removal” on page 282.
- Step 2.** Remove the front panel as described in “Front Panel Removal” on page 284.
- Step 3.** Disconnect the all semi-rigid cables from the switch on the left side. (refer to the figure as shown in Table 6-4 on page 305)

NOTE The label on the semi-rigid cable show the last two digits of the part number.

- Step 4.** Release the switch cable from the cable clamp (item 1).
- Step 5.** Remove the two screws fastening the switch holder.(item 2)
- Step 6.** Disconnect the switch cables from the switches.

Replacement Procedure A8 RF Switch Replacement

Step 7. Remove the screws fastening the switches.

Figure 6-17 A8 RF Switch (receiver board side) Replacement

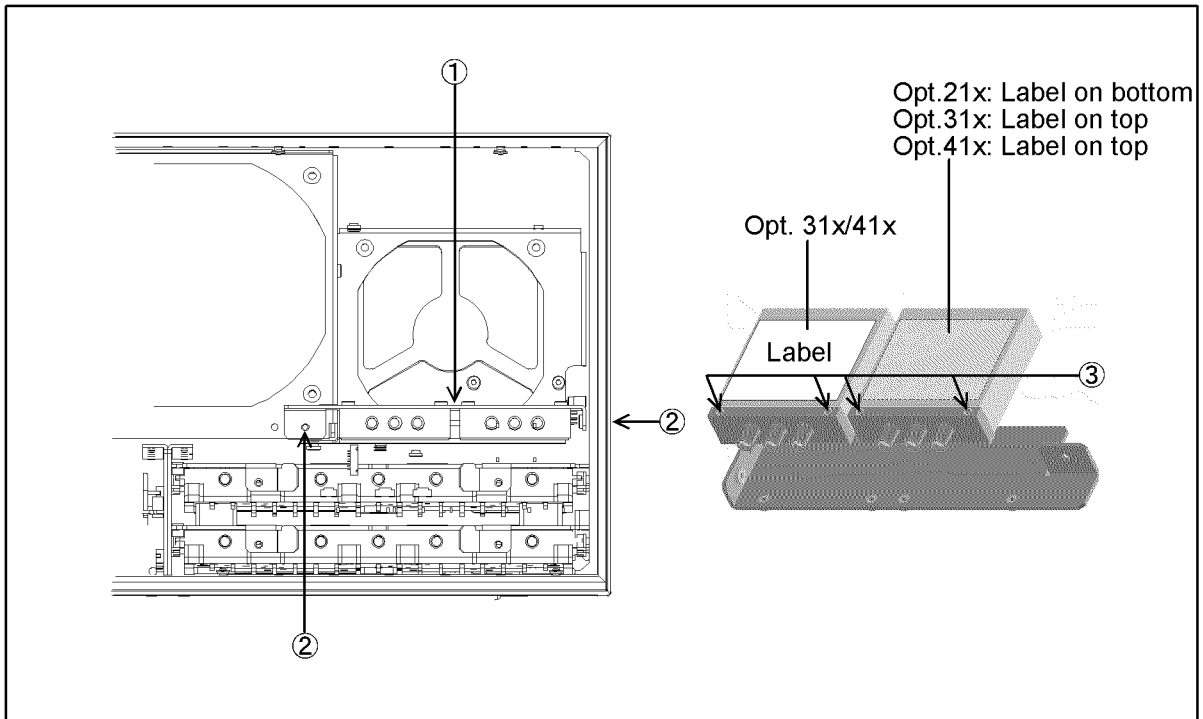

Replacement Procedure

Step 1. Fasten the switch as shown in Figure 6-17.

Step 2. Replace the switches by inverse procedure of removal.

NOTE

Confirm the switch cable is connected as shown in Figure 6-13 on page 302
Fasten the semi rigid cable using a torque wrench for replacement.

A7 Source Step Attenuator Removal (Option 214, 314 and 414)

Tools Required

- Pozidriv screwdriver, pt size #2 (medium) (where Pozidriv screws are in use)
- TORX screwdriver, T10, (T15, T20 where TORX screws are in use)
- Flat edge screwdriver
- Open-end wrench, 5/16
- Open-end torque wrench, 5/16 inch (set to 10 in-lb) (for reconnecting SMA connector)

Procedure

Refer to Figure 6-18 for this procedure.

- Step 1.** Remove the outer cover as described in “Outer Cover Removal” on page 282.
- Step 2.** Remove the front panel as described in “Front Panel Removal” on page 284.
- Step 3.** Disconnect the semi-rigid cables (item 1 and 2) from the A7 source step attenuator.

NOTE The label on the semi-rigid cable show the last two digits of the part number.

- Step 4.** Disconnect the flat cable from the attenuator.
- Step 5.** Remove the two screws fastening (item 3) the A7 source step attenuator holder from the front side.
- Step 6.** Remove the two screws fastening the A7 source step attenuator to the holder.

NOTE Fasten the semi rigid cable using a torque wrench for replacement.

Replacement Procedure
A7 Source Step Attenuator Removal (Option 214, 314 and 414)

Figure 6-18 A7 Source Step Attenuator Removal

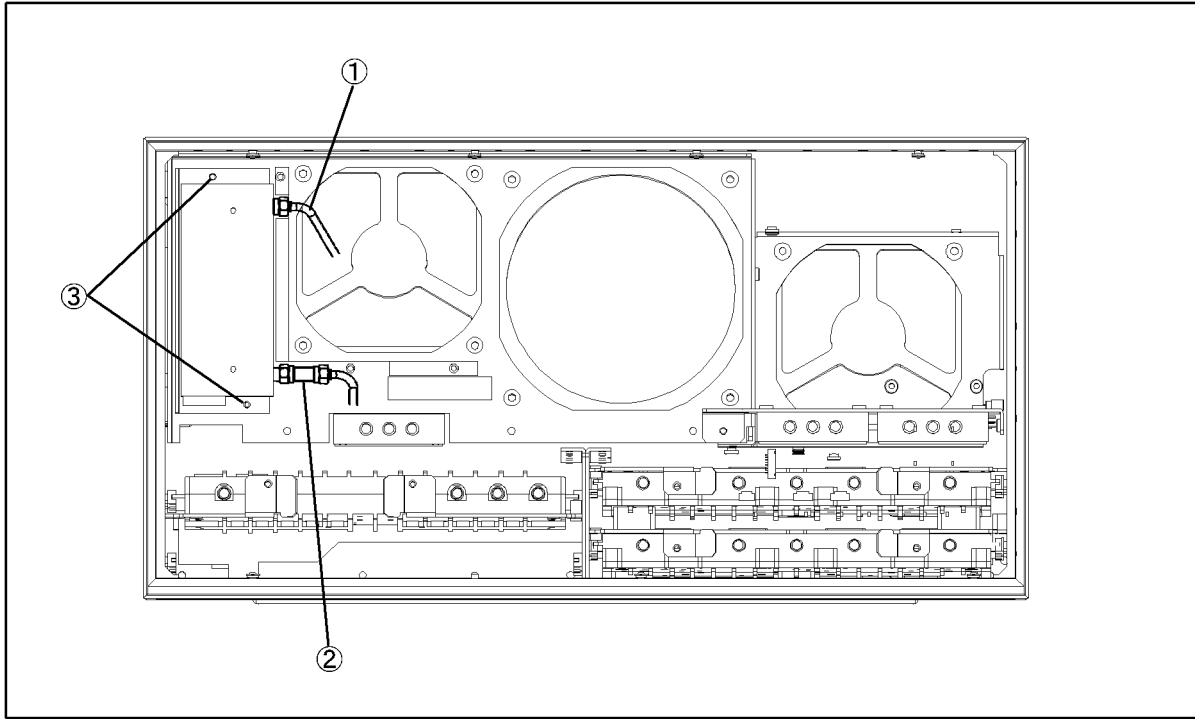

e5070ase230

A10 Analog Motherboard Removal

Tools Required

- Pozidriv screwdriver, pt size #2 (medium) (where Pozidriv screws are in use)
- TORX screwdriver, T10 , (T15, T20 where TORX screws are in use)
- Flat edge screwdriver
- Open-end wrench, 5/16 inch and 5/8 inch
- Open-end torque wrench, 5/16 inch (set to 10 in-lb) (for reconnecting SMA connector)

Procedure

- Step 1.** Remove the outer cover as described in “Outer Cover Removal” on page 282.
- Step 2.** Remove the front frame as described in “Front Panel Removal” on page 284
- Step 3.** Remove the source board as described in “A1 Source Board Removal” on page 297.
- Step 4.** Remove the receiver board as described in “A2 Receiver Board Removal” on page 299.
- Step 5.** Remove the receiver board as described in “A50 ATX Power Supply Assembly Removal” on page 290
- Step 6.** Disconnect the cables connected to the A10 analog motherboard.
- Step 7.** Remove the nine TORX T10 screws fastening the A10 analog mother board.

A21 Analog Interface Board Removal

Tools Required

- Pozidriv screwdriver, pt size #2 (medium) (where Pozidriv screws are in use)
- TORX screwdriver, T10, (T15, T20 where TORX screws are in use)

Procedure

Refer to Figure 6-19 for this procedure.

- Step 1.** Remove the outer cover as described in “Outer Cover Removal” on page 282.
- Step 2.** Disconnect the cables (item 1, 2 and 3) from the A21 Analog Interface board.
- Step 3.** Remove a TORX T10 screw (item 4) fastening the board to the rear panel.
- Step 4.** Lift the A21 Analog Interface Board.

Figure 6-19 A21 Analog Interface Board Removal

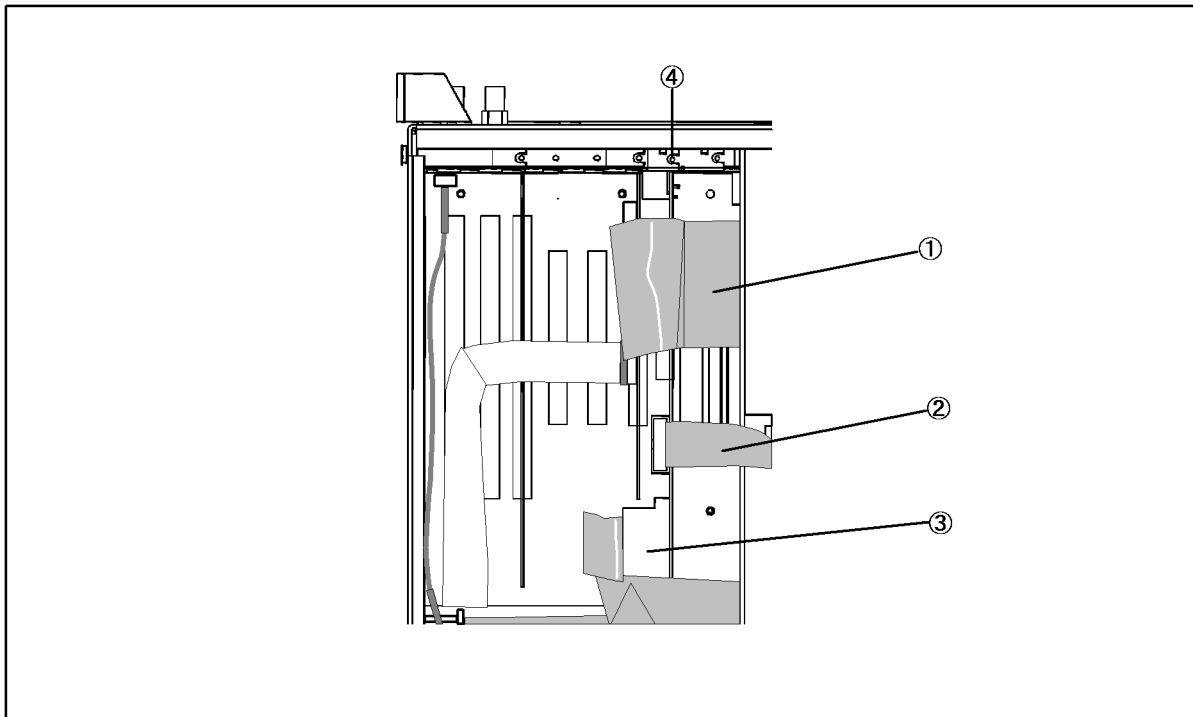

e5070ase246

A26 LCD Interface Card Removal

Tools Required

- Pozidriv screwdriver, pt size #2 (medium) (where Pozidriv screws are in use)
- TORX screwdriver, T10, (T15, T20 where TORX screws are in use)
- flat edge screwdriver

Procedure

Refer to Figure 6-21 for this procedure.

- Step 1.** Remove the outer cover as described in “Outer Cover Removal” on page 282.
- Step 2.** Disconnect the mylar cables (item 1) from the display board.
- Step 3.** Remove the TORX T10 screw (item 2) fastening the card to the rear panel.
- Step 4.** Lift the A26 LCD Interface Card.

NOTE

Use the following procedure when you handle the mylar ribbon cable. The mylar cable and their connector are very fragile. To replace to a new mylar cable is recommended when you are instructed to disconnect and connect the mylar cable frequently.

To disconnect the cable:

- Step 1.** Pry up the retainer slightly at either end of the connector as shown in Figure 6-20, using a small flat edge screwdriver.

Figure 6-20

pry up the retainer

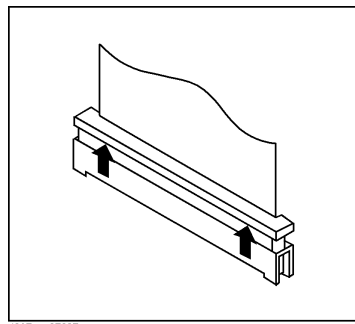

4287ase07007

- Step 2.** Pull the mylar ribbon cable out of the connector.
-

Figure 6-21 A26 LCD Interface Card Removal

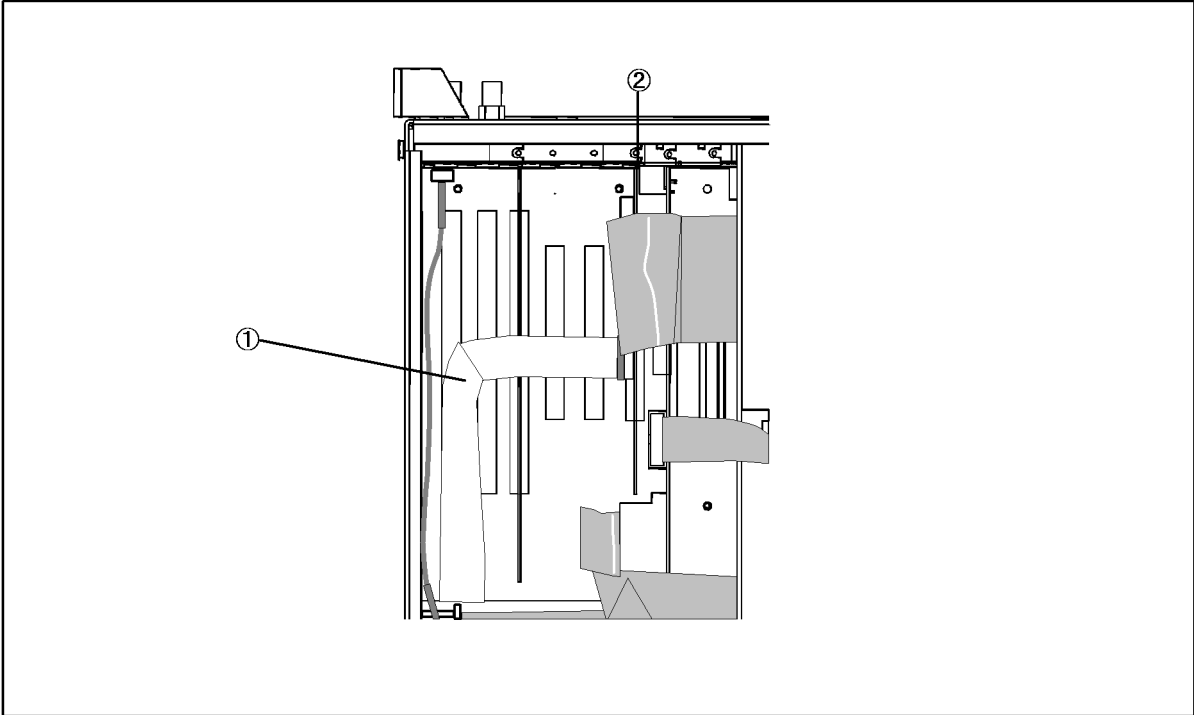

e5070ase247

A24 GPIB Card Replacement

Tools Required

- Pozidriv screwdriver, pt size #2 (medium) (where Pozidriv screws are in use)
- TORX screwdriver, T10, (T15, T20 where TORX screws are in use)

Removal Procedure

Refer to Figure 6-22 for this procedure.

- Step 1.** Remove the outer cover as described in “Outer Cover Removal” on page 282.
- Step 2.** Remove the TORX T10 screw (item 1) fastening the card to the rear panel.
- Step 3.** Lift the A24 GPIB Card.

CAUTION

Be careful not to injure the digital mother board and the cable connected the display board to the front assembly.

Figure 6-22 A24 GPIB Card Removal

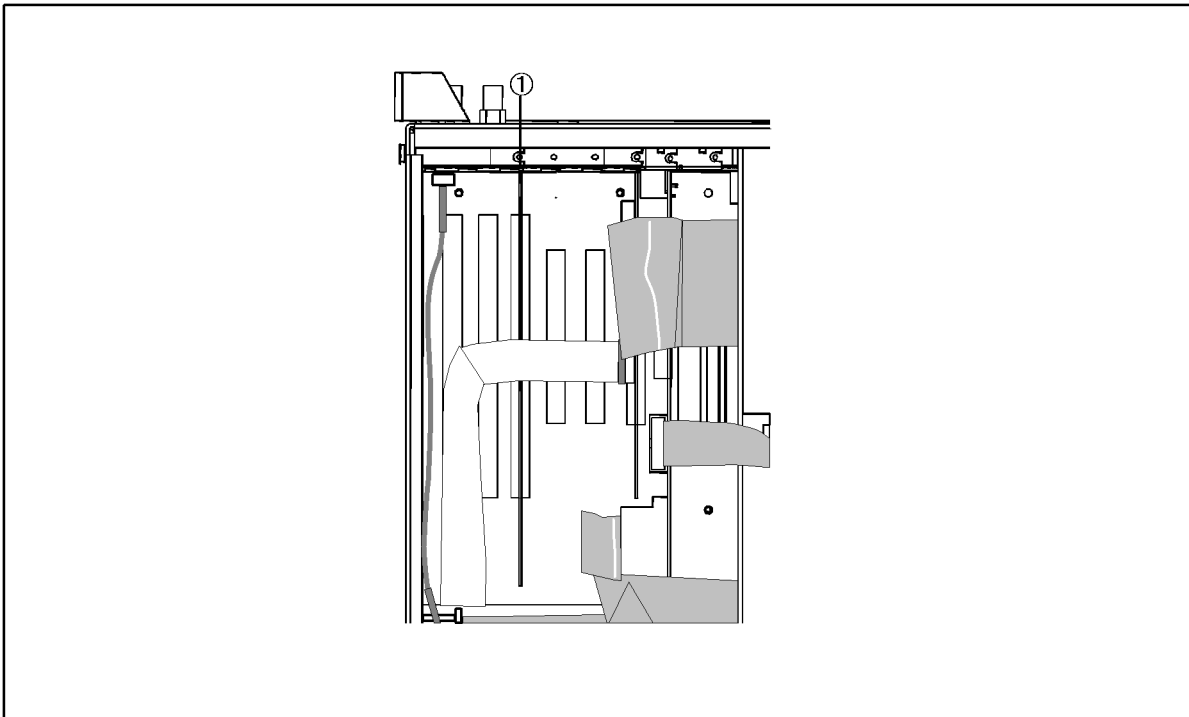

e5070ase248

Replacement Procedure

- Step 1.** Confirm that the bit switch on the new A24 GPIB card is set as shown in Figure 6-23.

Step 2. Replace the new A24 GPIB card by inverse procedure of removal.

Figure 6-23

Assignment of the Bit switches on the A24 GPIB card

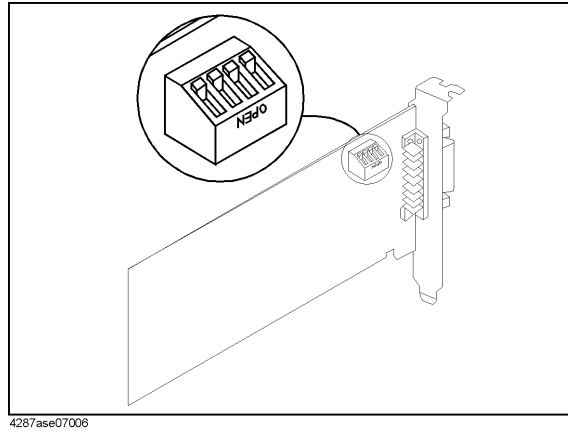

A22 Front Panel Keyboard Removal

Tools Required

- Pozidriv screwdriver, pt size #2 (medium) (where Pozidriv screws are in use)
- TORX screwdriver, T10, (T15, T20 where TORX screws are in use)
- Flat edge screwdriver
- Hex key, 1.5 mm

Procedure

Refer to Figure 6-24 for this procedure.

- Step 1.** Remove the front panel as described in “Front Panel Removal” on page 284.
- Step 2.** Release the clamped cables from the clamp (item 1) on the cover.
- Step 3.** Disconnect the cables (item 2 and 3) from the touch screen controller if the option 016 is installed.
- Step 4.** Remove the four TORX T10 screws (item 4) fastening the cover to the front panel.
- Step 5.** Disconnect the two cables (item 5 and 6) connected through the cover.

NOTE The item 6 is not connected in the E5070A/E5071A without the option 016.

- Step 6.** Disconnect the two cables (item 7 and 8) from the front keyboard.
- Step 7.** Remove the knob from the front panel with a 1.5 mm hex key.
- Step 8.** Remove the two TORX T10 screws (item 9) fastening the inverter assembly.
- Step 9.** Remove the six screws (item 10) fastening the A22 front panel keyboard.
- Step 10.** Separate the keyboard into the board and the rubber key.

NOTE Insert the whole jut of the rubber key into the hole on the board as shown in Figure 6-24 when replacing the A22 front panel keyboard.

Figure 6-24 A22 Front Panel Keyboard Removal

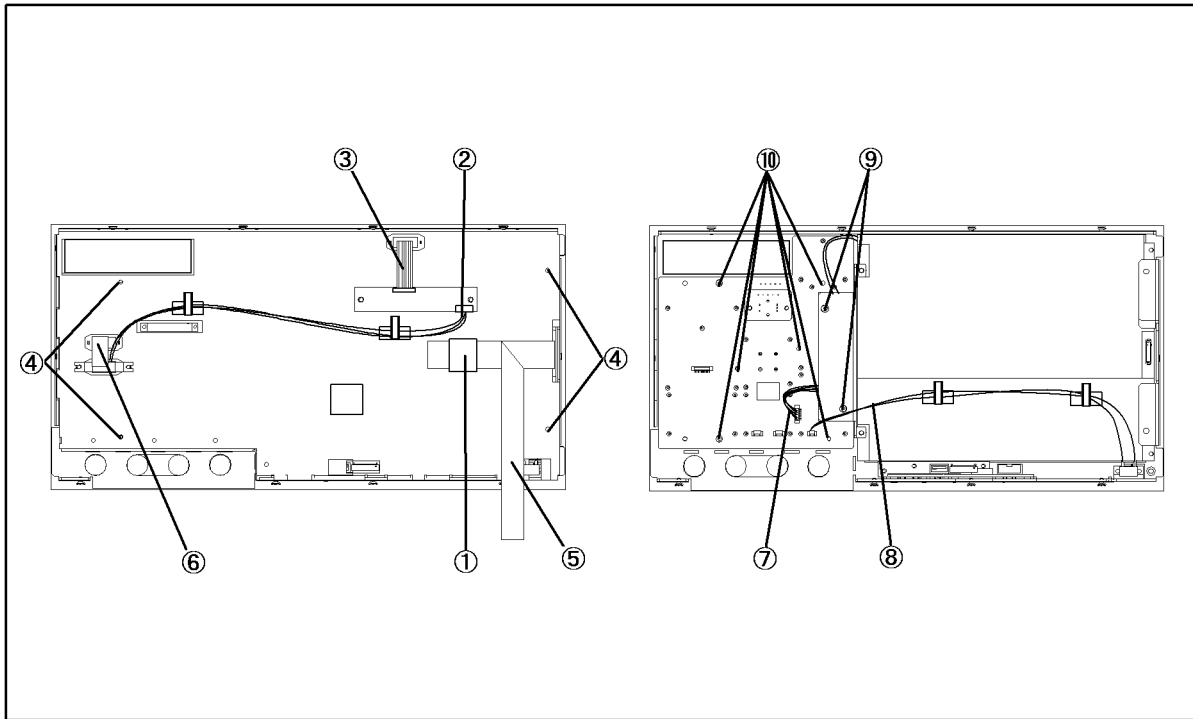

e5070ase239

A52 Inverter Board Removal

Tools Required

- Pozidriv screwdriver, pt size #2 (medium) (where Pozidriv screws are in use)
- TORX screwdriver, T8 and T10, (T15, T20 where TORX screws are in use)
- Flat edge screwdriver

Procedure

Refer to Figure 6-25 for this procedure.

- Step 1.** Remove the front panel as described in “Front Panel Removal” on page 284.
- Step 2.** Release the clamped cables from the clamp (item 1) on the cover.
- Step 3.** Disconnect the cables (item 2 and 3) from the touch screen controller if the option 016 is installed.
- Step 4.** Remove the four TORX T10 screws (item 4) fastening the cover to the front panel.
- Step 5.** Disconnect the two cables (item 5 and 6) connected through the cover.

NOTE

The item 6 is not connected in the E5070A/E5071A without the option 016.

- Step 6.** Disconnect the two cables (item 7 and 8) from the inverter.
- Step 7.** Remove the two TORX T10 screws (item 9) fastening the inverter assembly.
- Step 8.** Remove the two TORX T8 screws (item 10) fastening the inverter to the holder.

Figure 6-25 A52 Inverter Board Removal

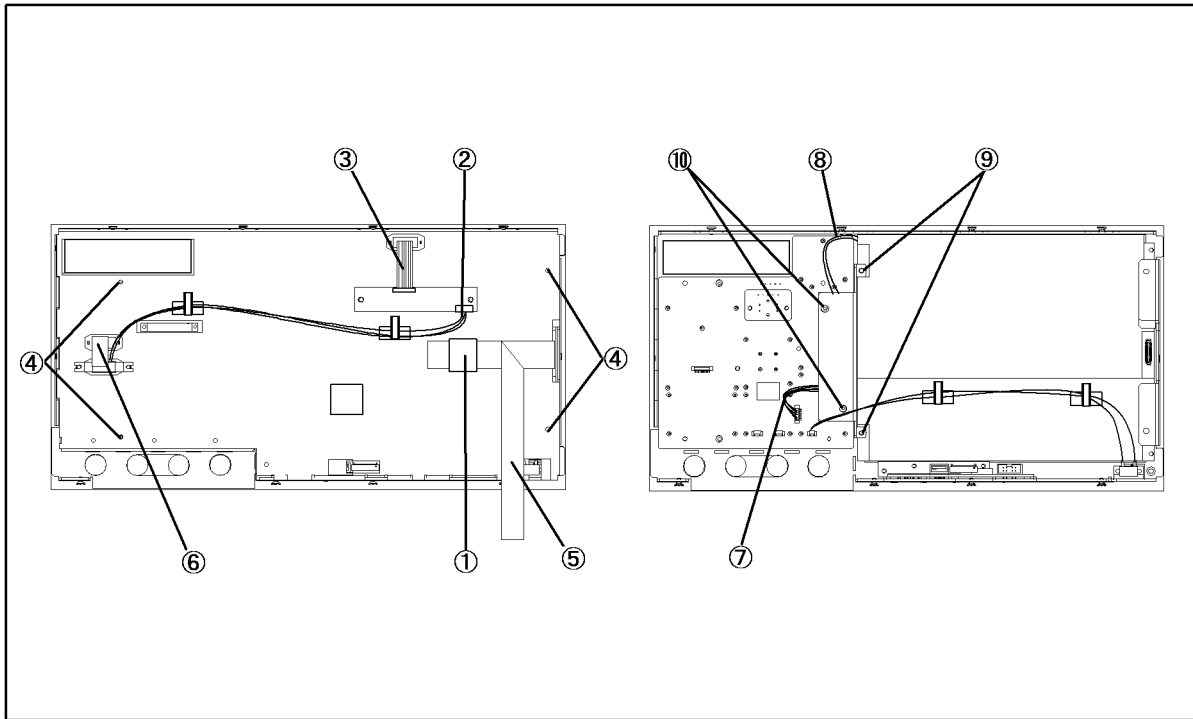

e5070ase245

A51 LCD Display Removal

Tools Required

- Pozidriv screwdriver, pt size #2 (medium) (where Pozidriv screws are in use)
- TORX screwdriver, T10, (T15, T20 where TORX screws are in use)
- Flat edge screwdriver

Procedure

Refer to Figure 6-26 for this procedure.

- Step 1.** Remove the front panel as described in “Front Panel Removal” on page 284.
- Step 2.** Release the clamped cables from the clamp (item 1) on the cover.
- Step 3.** Disconnect the cables (item 2 and 3) from the touch screen controller if the option 016 is installed.
- Step 4.** Remove the four TORX T10 screws (item 4) fastening the cover to the front panel.
- Step 5.** Disconnect the two cables (item 5 and 6) connected through the cover.

NOTE

The item 6 is not connected in the E5070A/E5071A without the option 016.

- Step 6.** Release the cable from the cable clamp (item 7) on the LCD.
- Step 7.** Disconnect the cable (item 8) connected to the inverter.
- Step 8.** Remove the four TORX T10 screws (item 9) fastening the A51 LCD Display to the front panel.

Figure 6-26 A51 LCD Removal

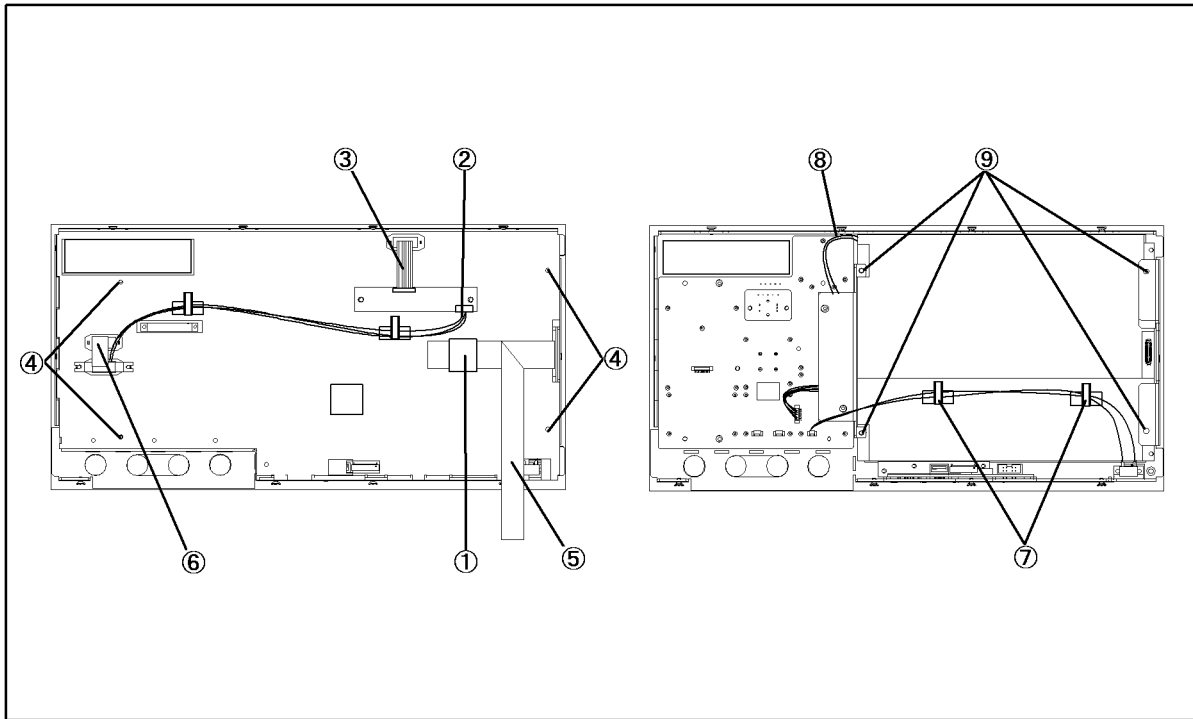

e5070ase244

Calibration of the Touch Screen

When you have replaced the LCD on a E5070A/E5071A equipped with an Option 016 touch screen, you have to calibrate the touch screen. Follow the procedure described on “Calibration of the Touch Screen” on page 286.

LCD Backlight Removal

Tools Required

- Pozidriv screwdriver, pt size #2 (medium) (where Pozidriv screws are in use)
- TORX screwdriver, T10, (T15, T20 where TORX screws are in use)
- Flat edge screwdriver

Removal Procedure

Refer to Figure 6-27 for this procedure.

Step 1. Remove the A51 LCD display as described in “A51 LCD Display Removal” on page 320.

Step 2. Push the stopper (item 1) and slide the backlight as shown in Figure 6-27.

Figure 6-27 LCD Backlight Removal

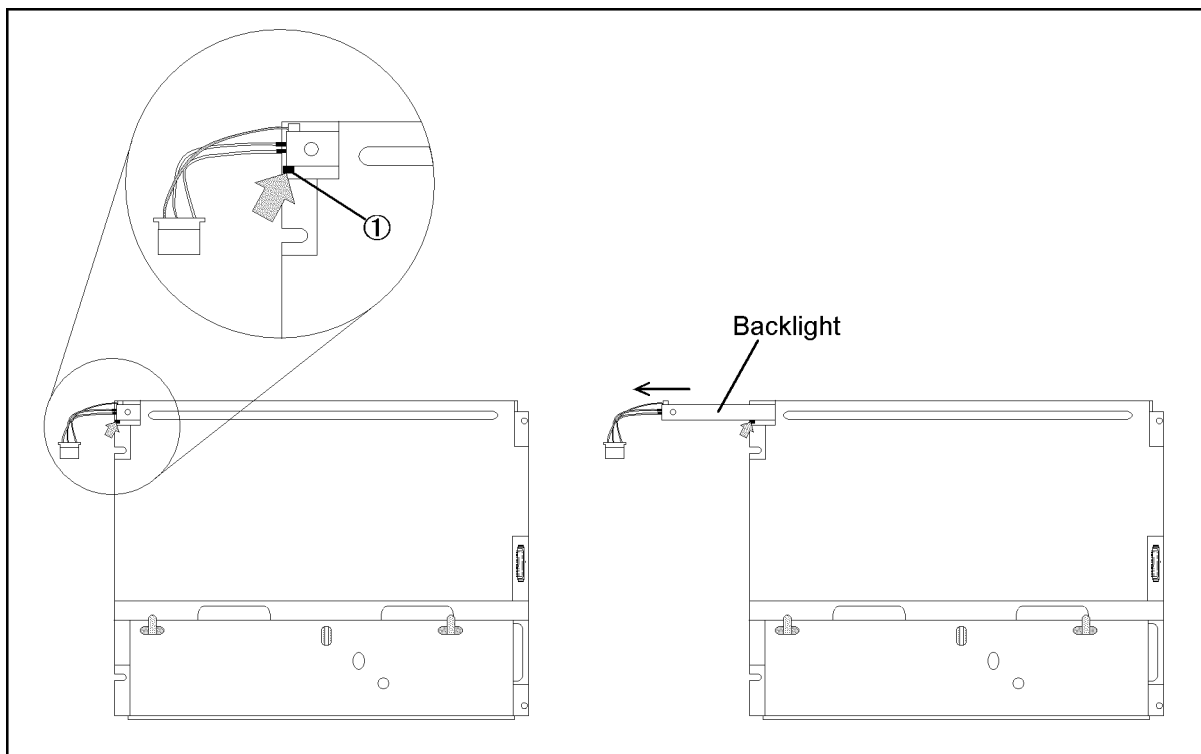

e5070bse100

N Connector Removal

Tools Required

- Pozidriv screwdriver, pt size #2 (medium) (where Pozidriv screws are in use)
- TORX screwdriver, T10, (T15, T20 where TORX screws are in use)
- Flat edge screwdriver
- Open-end wrench, 5/16
- Open-end torque wrench, 5/16 inch (set to 10 in-lb) (for reconnecting SMA connector)

Removal Procedure

Refer to Figure 6-28 for this procedure.

- Step 1.** Remove the front panel as described in “Front Panel Removal” on page 284.
- Step 2.** Remove the trim from the right side of the front panel.
- Step 3.** Remove the Pozidriv screw (item 1) fastening the N-connector holder from the right side.
- Step 4.** Remove the two Pozidriv screws (item 2) from the bottom.
- Step 5.** Disconnect the semi-rigid cables from the N connector. (refer to the figure as shown in Table 6-5)

NOTE

The label on the semi-rigid cable show the last two digits of the part number.

Table 6-5

Reference Figure

Option	Figure
213	Figure 5-9 on page 248
214	Figure 5-10 on page 249
313	Figure 5-11 on page 250
314	Figure 5-12 on page 252
413	Figure 5-13 on page 254
414	Figure 5-14 on page 256

- Step 6.** Remove the washers and nuts from the N connectors.
- Step 7.** Remove the N connector from the holder.

NOTE

Match the dents on the holder and the juts on the connector for replacement.

NOTE

Fasten the semi rigid cable using a torque wrench for replacement.

Replacement Procedure
N Connector Removal

Figure 6-28 N Connector Removal

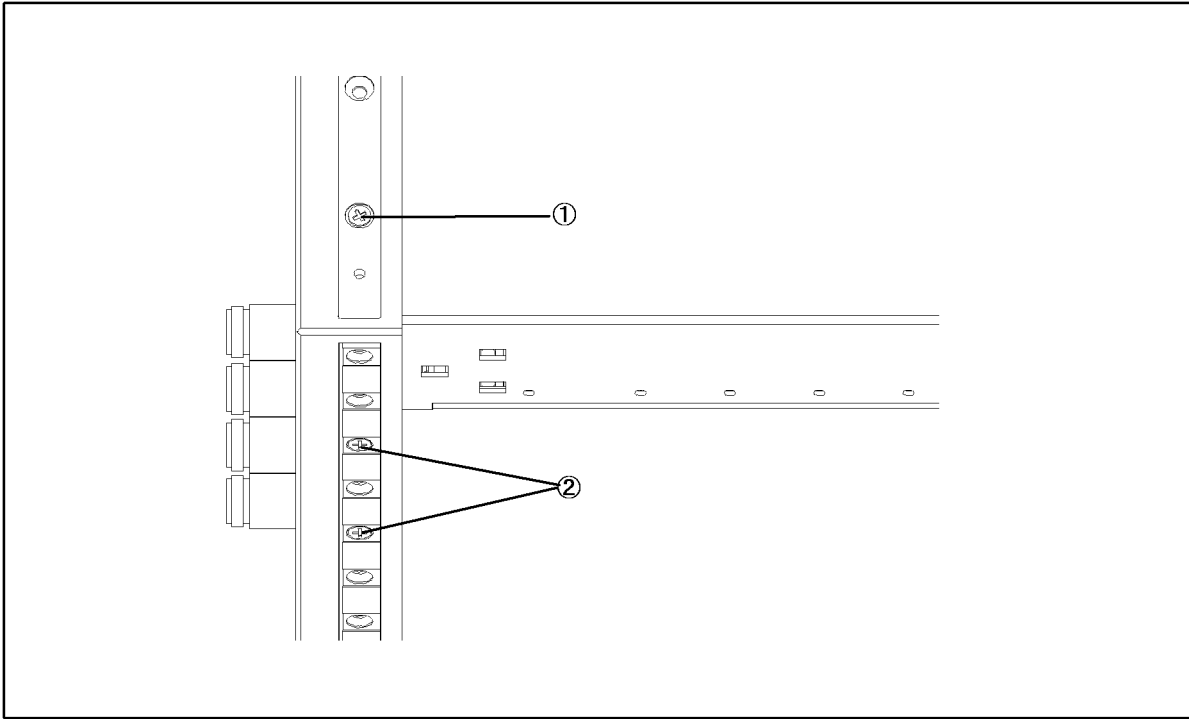

e5070ase249

7**Post-Repair Procedures**

This chapter lists the procedures required to verify the E5070A/E5071A operation after an assembly is replaced with a new one.

Post-Repair Procedures

Table 7-1 *Post Repair Procedures* lists the required procedures that must be performed after the replacement of an assembly, CPU or DIMM(Memory). These are the recommended minimum procedures to ensure that the replacement is successfully completed.

Table 7-1 Post-Repair Procedures

Replaced Assembly or Part	Required Adjustments Correction Constants (CC)	Verification
A1 Source Board	Perform the following required adjustments using the “Source Board” in Spot Adjustment of the program. Frequency Reference Adjustment Source Power Adjustment Test Port Characteristics Adjustment	“Troubleshooting Using Internal Test” on page 156 “Troubleshooting Using External Test” on page 177 Frequency Accuracy Test RF Output Level Accuracy and Flatness Test RF Output Level Linearity Test Trace Noise CW Test Crosstalk Test System Dynamic Range Test Dynamic Accuracy Test Uncorrected System Performance Test
A14 Receiver-RF Board	Perform the following required adjustments using the “Receiver (RF) Board” in Spot Adjustment of the program. Source Power Adjustment Test Port Characteristics Adjustment	“Troubleshooting Using Internal Test” on page 156 “Troubleshooting Using External Test” on page 177 RF Output Level Accuracy and Flatness Test RF Output Level Linearity Test Trace Noise CW Test Crosstalk Test System Dynamic Range Test Dynamic Accuracy test Uncorrected System Performance Test
A17 Receiver-IF Board	Perform the following required adjustments using the “Receiver (IF) Board” in Spot Adjustment of the program. IF Range Gain/Phase Adjustment Source Power Adjustment Test Port Characteristics Adjustment	“Troubleshooting Using Internal Test” on page 156 “Troubleshooting Using External Test” on page 177 Trace Noise CW Test Crosstalk Test System dynamic range Test Dynamic accuracy test Uncorrected system performance

Table 7-1 Post-Repair Procedures

Replaced Assembly or Part	Required Adjustments Correction Constants (CC)	Verification
A5 Crystal Oven (for 1E5)	Perform the following required adjustment using the “Crystal Oven (for 1E5)” in Spot Adjustment of the program. Oven Reference Adjustment (Opt. 1E5)	Frequency Accuracy Test(with Option 1E5)
A8 Source Switch	Perform the following required adjustments using the “RF SW” in Spot Adjustment of the program. Source Power Adjustment Test Ports Characteristics Adjustment	“Troubleshooting Using Internal Test” on page 156 “Troubleshooting Using External Test” on page 177 Trace Noise CW Test Crosstalk Test System dynamic range Test Dynamic accuracy test Uncorrected system performance
A6 RF Switch / Temperature Controller Board	No adjustment needed	“Troubleshooting Using Internal Test” on page 156
A7 Source Step Attenuator (Opt. 214/314/414)	Perform the following required adjustments using the “Att (for 214/314/414)” in Spot Adjustment of the program. Source Power Adjustment Test Port Characteristics Adjustment	“Troubleshooting Using Internal Test” on page 156 “Troubleshooting Using External Test” on page 177 RF Output Level Accuracy and Flatness Test RF Output Level Linearity Test Trace Noise CW Test Crosstalk Test System Dynamic Range Test Dynamic Accuracy Test Uncorrected System Performance Test
A10 Analog Motherboard	No adjustment needed	Inspect the Booting Process When the symptom of failure is out of specification, perform the performance test.
A20 Digital Motherboard	Set jumpers and BIOS parameters on the A20. For details, see “To configure the A20 Digital Motherboard and BIOS” on page 216.	Inspect the Booting Process
A21 Analog Interface Board	Perform the following required adjustments using the “Analog Interface” in Spot Adjustment of the program. Writing ID	Inspect the Booting Process “To Check the Front Panel” on page 167 “To Check the External Trigger Input” on page 170

7. Post-Repair Procedures

Table 7-1 Post-Repair Procedures

Replaced Assembly or Part	Required Adjustments Correction Constants (CC)	Verification
A22 Front Panel Keyboard	No adjustment needed	“Troubleshooting Using Internal Test” on page 156 “To Check the Front Panel” on page 167
A23 Handler I/O Board	No adjustment needed	“Troubleshooting Using Internal Test” on page 156
A24 GPIB Board	No adjustment needed	“To Check the GPIB” on page 176
A26 Display Board	No adjustment needed	Inspect the Booting Process “Troubleshooting Using Internal Test” on page 156 “To Check the Video output” on page 170
A27 Mass Storage Disk Drive	Perform “HDD” in Spot Adjustment of the program. Calibration of the Touch Screen (for opt. 016)	Inspect the Booting Process
A28 FDD	No adjustment needed	“To Check the FDD” on page 170
A50 Power Supply Assembly	No adjustment needed	Inspect the Booting Process
A51 LCD	Not adjustment needed	Inspect the Booting Process “Troubleshooting Using Internal Test” on page 156 “To Check the LCD” on page 169
Touch panel (for Opt. 016)	Calibration of the Touch Screen	Inspect the Booting Process “Troubleshooting Using Internal Test” on page 156 “To Check the LCD” on page 169
A52 Inverter Board	No adjustment needed	Inspect the Booting Process “Troubleshooting Using Internal Test” on page 156
CPU	No adjustment needed	Inspect the Booting Process
DIMM	No adjustment needed	Inspect the Booting Process

A **Manual Changes**

This appendix contains the information required to adapt this manual to versions or configurations of the E5070A/E5071A manufactured earlier than the current printing date of this manual. The information in this manual applies directly to E5070A/E5071A units with the serial number that is printed on the title page of this manual.

Manual Changes

To adapt this manual to your E5070A/E5071A, refer to Table A-1 and Table A-2.

Table A-1 Manual Changes by Serial Number

Serial Prefix or Number	Make Manual Changes
E5070A: JP1KJ00101 to JP1KJ00110 E5071A: JP1KJ00101 to JP1KJ00237	Change 1

Table A-2 Manual Changes by Firmware Version

Version	Make Manual Changes

Agilent Technologies uses a two-part, ten-character serial number that is stamped on the serial number plate (Figure A-1). The first five characters are the serial prefix and the last five digits are the suffix.

Figure A-1 Serial Number Plate



serial

Change 1

The chassis is changed for the following serial number.

Model	Serial Number
E5070A	JP1KJ00101 to JP1KJ00110
E5071A	JP1KJ00101 to JP1KJ00237

“Top View (Major Assemblies)” on page 236

Change as follows.

Figure A-2 Top View (Major Assembly)

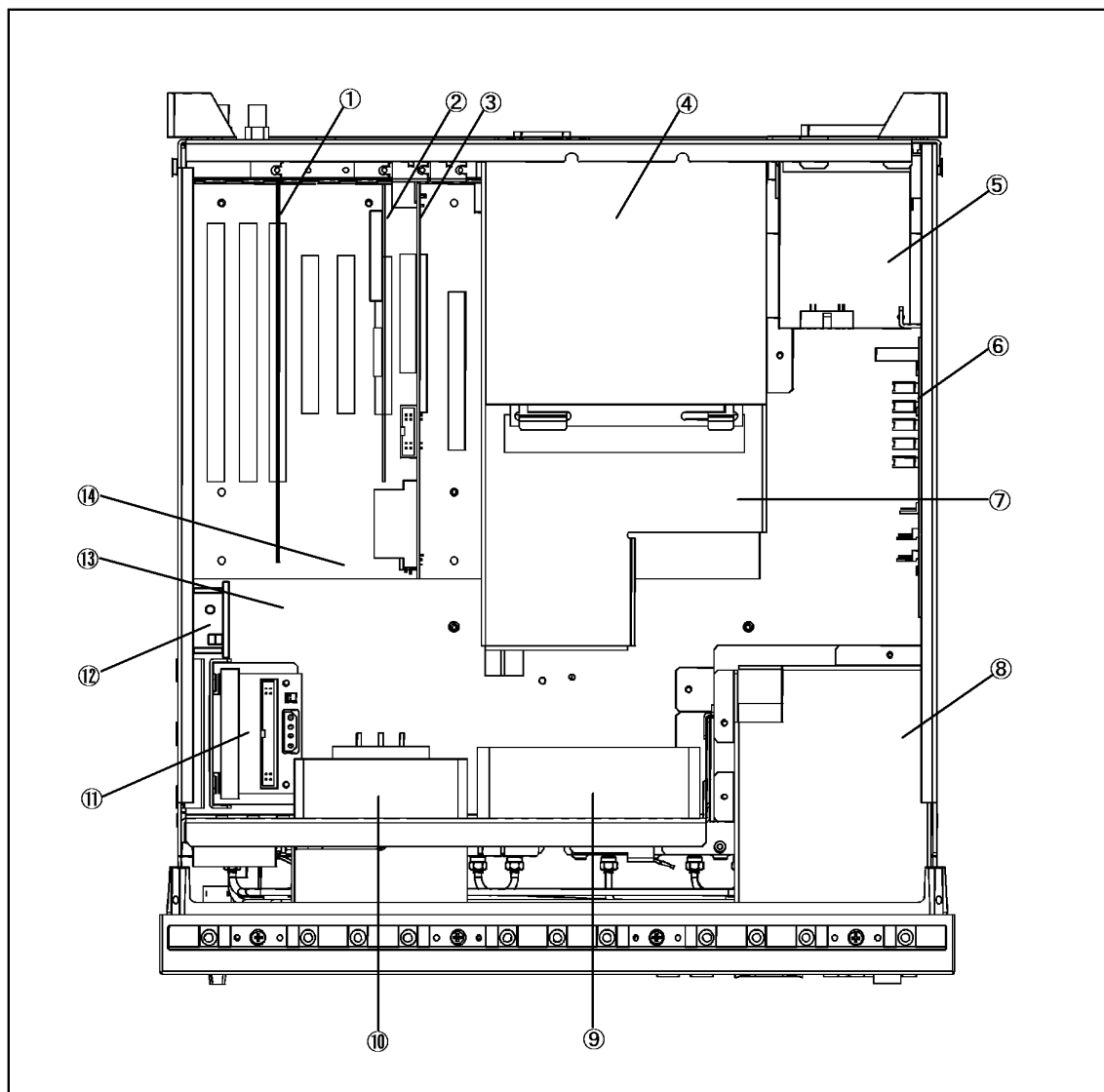

e5070ase263

Manual Changes
Change 1

Table A-3 Top View (Major Assembly)

Ref. Desig.	Agilent Part Number	C/D	Qty.	Description
1	54810-66525	1	1	A26 LCD INTERFACE CARD
2	82341C #002	8	1	A24 GPIB CARD
3	E5070-66521	5	1	A10 ANALOG OTHER BOARD
4	0950-3961	3	1	A50 ATX POWER SUPPLY
5	E5070-66523	7	1	A23 HANDLER I/O BOARD
6	E5070-66586	2	1	A6 SWITCH CONTROL BOARD
7	E5070-01201	2	1	PLATE
8	See Table 5-18	-	1	A28 FDD ASSEMBLY
9	E5070-61001	6	1	B1 FAN ASSY
10	E5070-61002	7	1	B1 FAN ASSY
11	See Table 5-19	-	1	A27 MASS STORAGE DISK DRIVE ASSEMBLY
12	E4991-66505	7	1	A5 CRYSTAL OVEN (Opt. 1E5)
13	E5070-60001	0	1	CHASSIS
14	E5070-61030	1	1	A20 DIGITAL MOTHERBOARD

“Top View (Miscellaneous Parts)” on page 240

Figure A-3 Top View (Miscellaneous Parts)

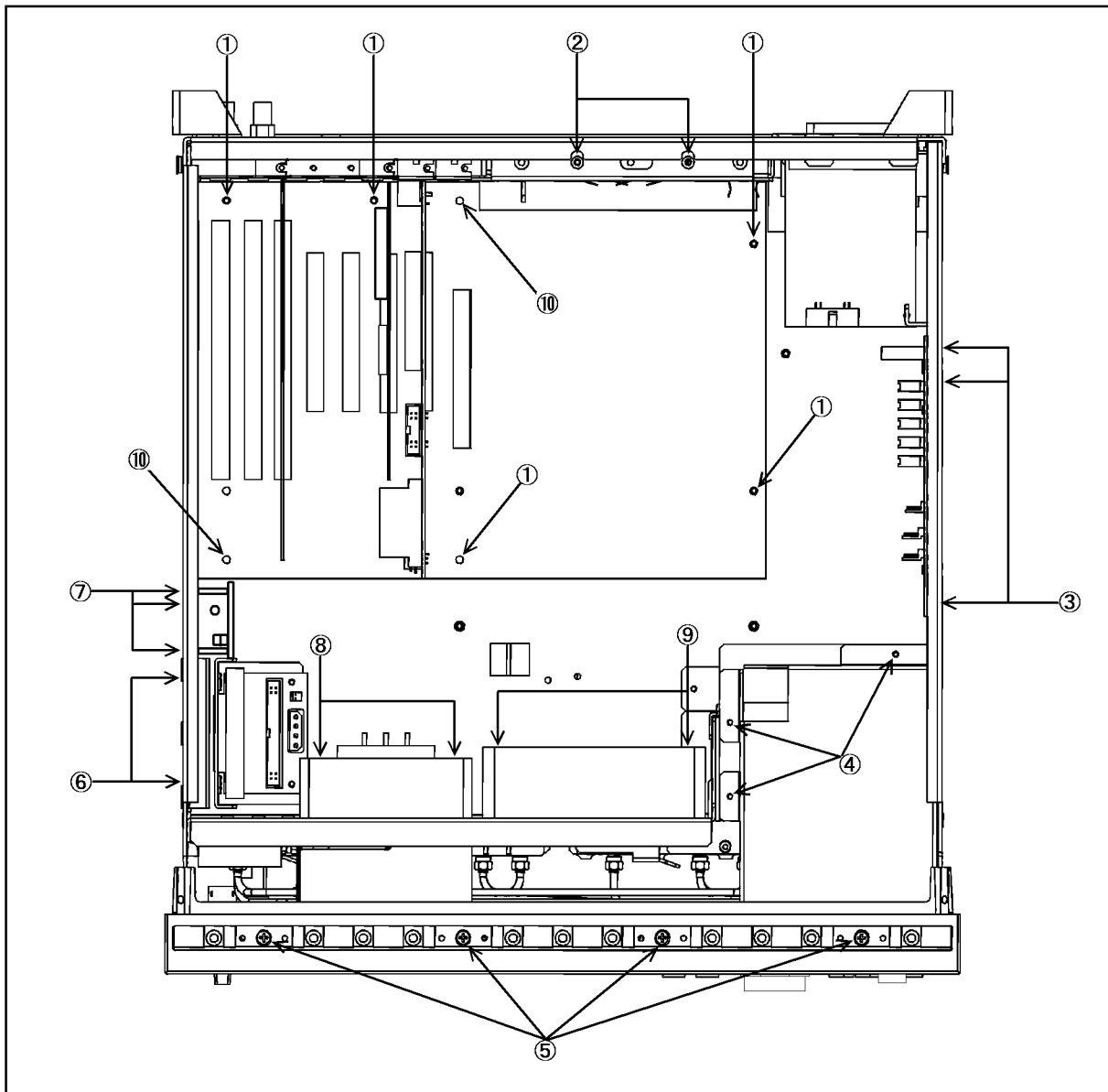

e5070ase264

A. Manual Changes

Manual Changes
Change 1

Table A-4 Top View (Miscellaneous Parts)

Ref. Desig.	Agilent Part Number	C/D	Qty.	Description
1	0515-0372	2	5	SCREW-MACH M3.0 x 8 PN T10
2	0515-1946	8	2	SCREW-MACH M3.0 x 6 FL T10
3	0515-1946	8	3	SCREW-MACH M3.0 x 6 FL T10
4	0515-0430	3	3	SCREW-MACH M3.0 x 6 PN T10
5	0515-1382	6	4	SCREW-MACH M3.5 x 6 FL T10
6	0515-0372	2	4	SCREW-MACH M3.0 x 8 PN T10
7	0515-1946	8	3	SCREW-MACH M3.0 x 6 FL T10 (Opt. 1E5)
8	0515-2216	7	4	SCREW-MACH M4.0 x 40 PN T20
9	0515-0964	8	4	SCREW_MACH M4.0 x 45 PN
10	0380-4832	0	2	SPACER

Rear View

Figure A-4

Rear View

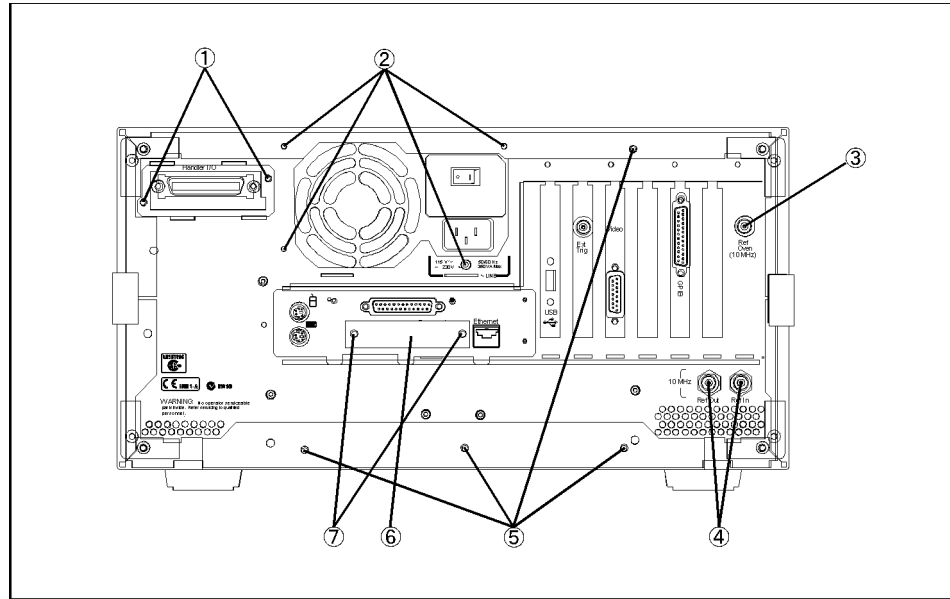

e5070ase054

Table A-5 Rear View

Ref. Desig.	Agilent Part Number	C/D	Qty.	Description
1	0515-0372	2	2	SCREW-MACH M3.0 x 8 PN T10
2	0515-0372	2	4	SCREW-MACH M3.0 x 8 PN T10
3	1250-0252	6	1	BNC CONNECTOR (Opt. 1E5)
	2950-0035	8	1	NUT-HEX-DBL-CHAM (Opt. 1E5)
	2190-0102	8	1	WSHR-LK INTL T (Opt. 1E5)
	6960-0041	1	1	PLUG HOLE
4	2950-0054	1	2	NUT-HEX-DBL-CHAM
	2190-0054	9	2	WSHR-LK INTL T
5	0515-1402	5	4	SCREW-MACH M3.5 x 8 PN T15
6	E5070-04004	9	1	COVER CONNECTOR
7	2200-0155	4	2	SCREW- MACH 4-40

Manual Changes
Change 1

Table 6-1 on page 281

See Table A-6.

Table A-6 Required Tools

Assembly	Pozidriv screwdriver	TORX screwdriver				flat edge screwdriver	cutting plier	plier	soldering iron	hex key	open wrench		open torque wrench
	pt size #2*1	T8	T10	T15*2	T20*2						1.5 mm	9/16 in.	
Outer Cover	√		√	√	√								
Front Panel	√		√	√	√	√							
Mass Storage	√		√	√	√								
FDD	√		√	√	√								
Handler I/O	√		√	√	√								
Power Supply	√		√	√	√		√						
CPU	√		√	√	√	√							
DIMM	√		√	√	√								
Digital Mother Board	√		√	√	√	√	√	√	√				
Source Board	√		√	√	√							√	√
Receiver Board	√		√	√	√								√
Fan & Switch Control Board	√		√	√	√								
Fan	√		√	√	√								
Reference Oven	√		√	√	√								
Switch	√		√	√	√	√							√
Attenuator	√		√	√	√	√							√
Analog Motherboard	√		√	√	√	√						√	√
Analog Interface Board	√		√	√	√								
Display Board	√		√	√	√	√							
GPIB Board	√		√	√	√								
Front Keyboard	√		√	√	√	√				√			
Inverter	√	√	√	√	√	√							
LCD	√		√	√	√	√							
LCD Backlight	√		√	√	√	√							
N connector	√		√	√	√	√					√		√

*1. where Pozidriv screws are in use

*2. where TORX screws are in use

Outer Cover Removal

Tools Required

- Pozidriv screwdriver, pt size #2 (medium) (where Pozidriv screws are in use)
- TORX screwdriver, T10, (T15, T20 where TORX screws are in use)

Procedure

Refer to Figure A-5 for this procedure.

- Step 1.** Disconnect the power cable from the E5070A/E5071A.
- Step 2.** Put a plastic cover (p/n 5959-8096, item 1) on the front panel of the analyzer and place the analyzer on flat table with its front panel down.
- Step 3.** Remove the four Pozidriv or TORX T20 screws (item 2) fastening the side strap handles.
- Step 4.** Remove the four Pozidriv or TORX T15 screws (item 3) fastening the four rear foot
- Step 5.** Remove the four Pozidriv or TORX T15 screws (item 4) fastening the cover from the rear side.
- Step 6.** Remove the two TORX T10 screws (item 5) fastening the cover.
- Step 7.** Remove the four TORX T10 screws (item 6) from the bottom.
- Step 8.** Remove the four bottom feet (item 7).
- Step 9.** Slide up the outer cover and remove it carefully.

Manual Changes
Change 1

Figure A-5

Outer Cover Removal

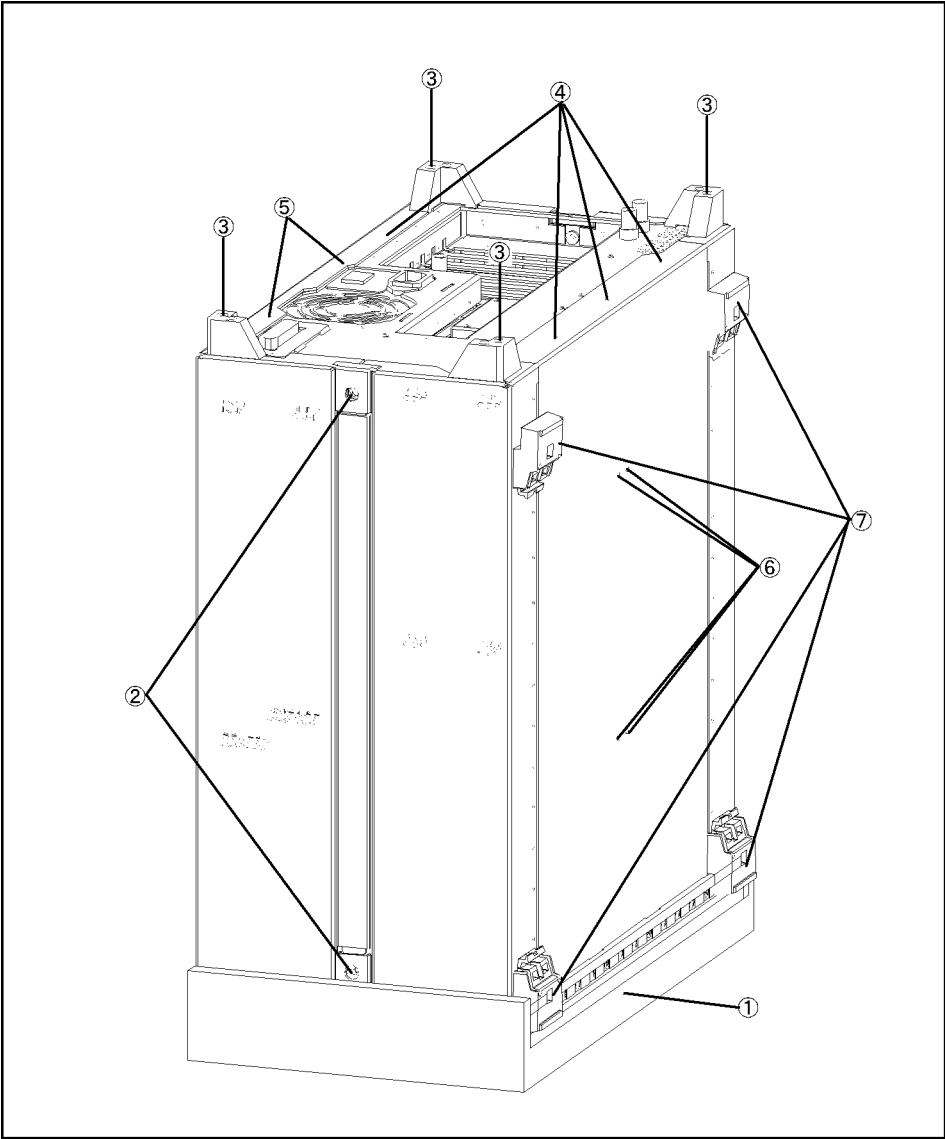

e5070ase153

“A50 ATX Power Supply Assembly Removal” on page 290

Change as follows

Tools Required

- Pozidriv screwdriver, pt size #2 (medium) (where Pozidriv screws are in use)
- TORX screwdriver, T10, (T15, T20 where TORX screws are in use)
- cutting plier or scissors

Procedure

Refer to Figure A-6 for this procedure.

- Step 1.** Remove the outer cover as described in “Outer Cover Removal” on page 282.
- Step 2.** Remove the handler I/O board as described in “Post-Repair Procedures” on page 326.
- Step 3.** Disconnect two flat cables (item 1 and 2) from the analog mother board.
- Step 4.** Disconnect the power supply cables (item 3, 4 and 5).
- Step 5.** Release all cables clamped on the power supply holder.
- Step 6.** Remove the screws (item 6) fastening the power supply holder.
- Step 7.** Remove the screws (item 7) from the rear panel.
- Step 8.** Slide the power supply assembly toward front side with the mount, then lift them.
- Step 9.** Cut the cable tie (item 8) if you replace the power supply.

CAUTION

Don't forget to clamp cables after replacement.

Figure A-6 Power Supply Assembly Removal

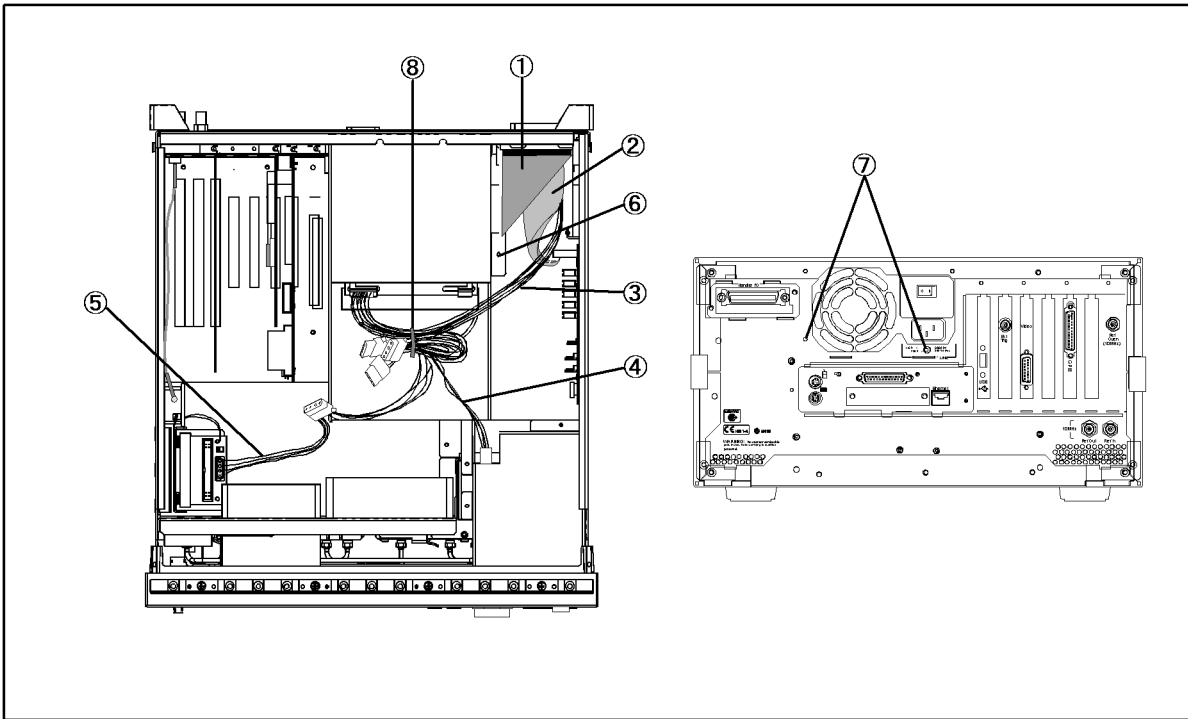

e5070ase265

“A20 Digital Motherboard Replacement” on page 295

Change as follows

Tools Required

- Pozidriv screwdriver, pt size #2 (medium) (where Pozidriv screws are in use)
- TORX screwdriver, T10, (T15, T20 where TORX screws are in use)
- Flat edge screwdriver
- *Plier*
- Cutting plier or scissors
- Soldering iron

Removal Procedure

Refer to Figure A-7 for this procedure.

Step 1. Remove the mouse, the external keyboard and the parallel printer cable if they are connected to the rear panel.

Step 2. Remove the outer cover as described in “Outer Cover Removal” on page 282

Step 3. Remove the following boards.

- Handler I/O board (refer to “A23 Handler I/O Board Removal” on page 289.)
- Analog Interface board (refer to “A21 Analog Interface Board Removal” on page 311.)
- GPIB board (refer to “A24 GPIB Card Replacement” on page 314.)
- Display board (refer to “A26 LCD Interface Card Removal” on page 312.)
- Power Supply (refer to “A50 ATX Power Supply Assembly Removal” on page 290.)

Step 4. Disconnect the following cables.

- Connected from the FDD (item 1).
- Connected from the mass storage disk assembly (item 2)
- Connected from the analog motherboard (item 3).
- Connected to the USB ports (item 4 and 5)

Step 5. Remove two screws fastening the plate (item 6).

Step 6. Remove two screws fastening the cover (item 7), then remove the cover.

Step 7. Disconnect the cable from the connector on the rear panel if the option 016 is installed.

Step 8. Remove five screws (item 8) fastening the digital motherboard.

Step 9. Release the digital motherboard from the stopper (item 9) pinching it with a plier.

Step 10. Lift the digital motherboard.

Figure A-7 Digital Motherboard Removal

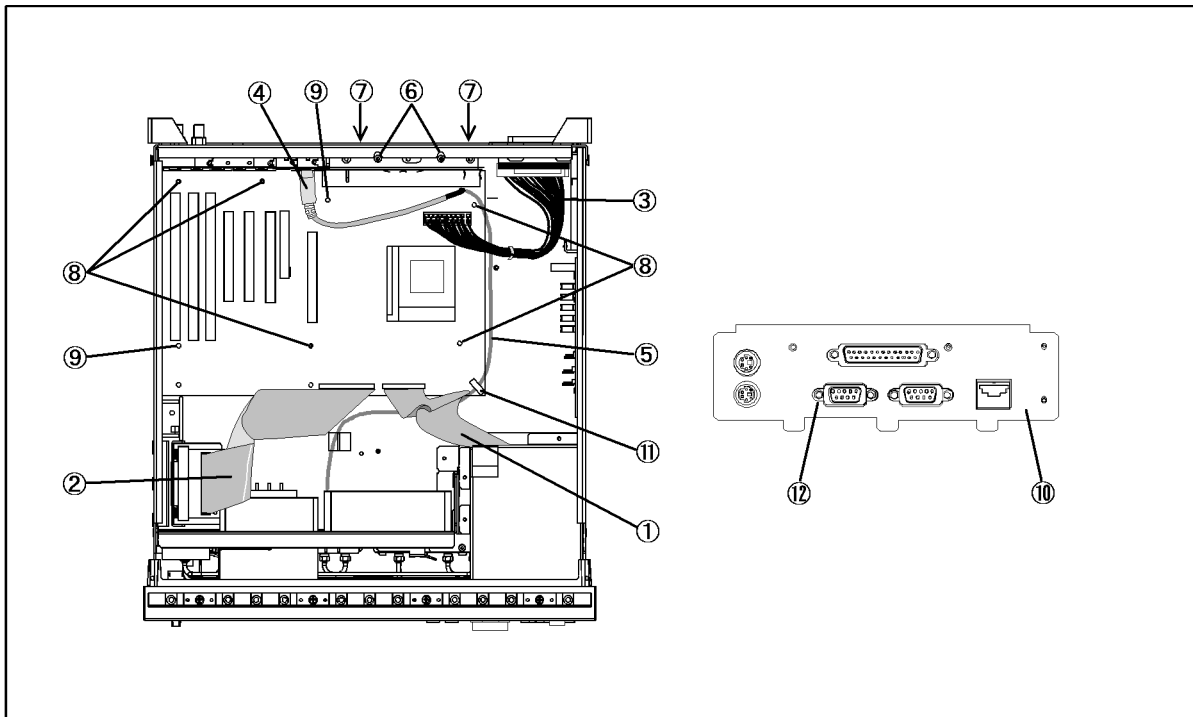

e5070ase266

Replacement Procedure

Refer to Figure A-7 for this procedure.

Step 1. Remove the CPU and CPU fan as described in “CPU Removal” on page 292.

Step 2. Remove the DIMM modules as described in “DIMM Module Removal” on page 294.

Step 3. Disassemble the guide plate (item 9) from rear side of the mother board.

Step 4. Cut the cable tie (item 10) holding the USB cable to the digital motherboard.

Manual Changes

Change 1

- Step 5.** Unsolder the USB cables.
- Step 6.** Solder the USB cables to the new board.
- Step 7.** Hold the USB cable to the new board by a cable tie.
- Step 8.** Remove a screw (item 11) from a serial connector.
- Step 9.** Place the guide plate to the rear side of the new board.
- Step 10.** Install the new board by the reverse procedure of removal.

B **System Recovery**

This appendix describes how to recover the operating system (Windows 98) when the operating system has damage.

System Recovery for the E5070A/E5071A

If something unusual happens to the Windows operating system or E5070A/E5071A firmware, resulting in failure to start up normally or in unstable operations, execute system recovery.

Executing system recovery affects data in the E5070A/E5071A (See Table B-1).

Table B-1 Data That Will be Deleted/Initialized and Data That Will be Not Affected by the Execution of System Recovery

Data That Will be Deleted or Initialized	Data That Will be Not Affected
User data written in Drive C (See below) <ul style="list-style-type: none">• User-installed driver software (deleted)• LAN settings (initialized)• GPIB control modes ^{*1}(initialized)	User files created in Drive D (user directory)

*1. System controller mode or addressable-only mode

Operating Steps

NOTE This operation requires a keyboard.

- Step 1.** Shut down the E5070A/E5071A.
- Step 2.** Connect a keyboard to the E5070A/E5071A.
- Step 3.** Press the standby switch of the E5070A/E5071A to turn on the power.
- Step 4.** Wait for a moment, and as soon as you see the following message in the upper part of the screen,

Push 'R' key to enter recovery mode [R,N]?

Press on the keyboard.

NOTE If you do not want to perform system recovery, simply wait a couple of seconds or press **N**.

- Step 5.** When you see the following message on the upper part of the screen,

Recover Hard disk (C drive) [Y, N]?

Press on the keyboard.

To stop executing system recovery, press (Under this condition, the E5070A/E5071A starts up normally).

- Step 6.** When Figure B-1 is displayed on the upper part of the screen, press on the keyboard

(This is the final confirmation of the starting of the execution of system recovery).

Figure B-1

System Recovery Confirmation Screen

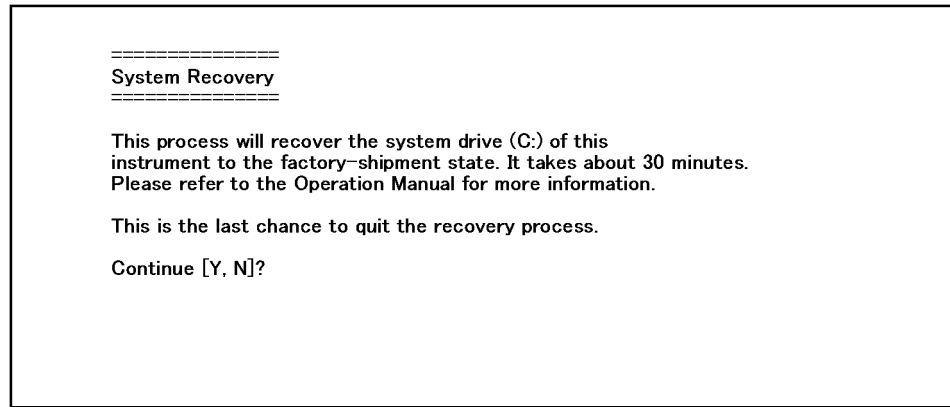

To stop executing system recovery, press N (Under this condition, the E5070A/E5071A starts up normally).

Step 7. After execution of system recovery has been started, Figure B-2 appears.

NOTE

Never turn off the power while system recovery is in progress.

Executing system recovery takes about 30 minutes.

Figure B-2

Screen Showing System Recovery in Progress

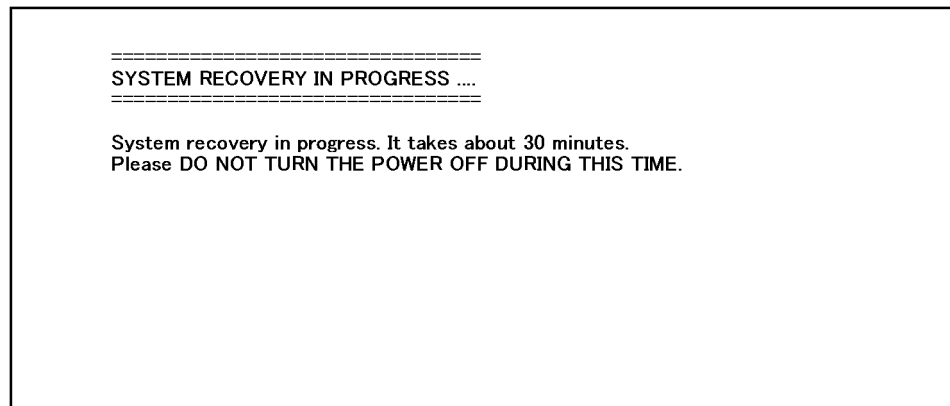

While system recovery is in progress, the system is restarted several times, with the message saying “Push `R` key to enter recovery mode [R, N]?” displayed. While this message is displayed, do not touch the keys.

Step 8. The System Setting Change Dialog Box (Figure B-3) will appear.

A panel appears showing that restarting the system is required after the system setup has been changed (Figure B-3). Select **Yes** (Press the return key).

System Recovery

System Recovery for the E5070A/E5071A

Figure B-3

System Setting Change Dialog Box



- Step 9.** The Enter Network Password dialog box appears, asking for the entry of the network password. You need not enter anything, but select **OK** (Press the return key).

NOTE

Entering a password at this step causes the panel to appear each time you start up the instrument, with entry of a password requested. Canceling causes the system to restart with the measurement screen appearing. However, this panel will continue to appear subsequently each time the system is started up.

- Step 10.** The System Setup Complete dialog box appears. Select **OK** (Press the return key) to restart the system. This concludes the execution of system recovery.

NOTE

If the system recovery fails due to system calibration data corruption, the following messages will be displayed. In this case, press **OK** to reboot.

Some calibration files are corrupt or missing.
System Setup Incomplete. Click "OK" button to reboot.

If those messages are displayed, or the problems are not solved by the system recovery, there is a possibility of a failure. Contact Agilent Technology's Customer Contact listed at the end of this guide or the company from which you bought the device.

C **Firmware Update**

This appendix describes how to update the E5070A/E5071A firmware. When you want to update the E5070A/E5071A firmware, refer to this appendix.

Firmware Update

Required Equipment

- E5070A or E5071A (with keyboard and mouse).
- Four blank floppy disks (DOS format).

How to make E5070A/E5071A Firmware Installation Disk

The following is the procedure to make the E5070A/E5071A Firmware Installation Disk.

Step 1. Copy the following files from Agilent Technologies web site to the four floppy disks using your computer's FDD.

- disk1(1 of 4)-- e5070.msi, e507001.cab
- disk2(2 of 4)-- e507002.cab
- disk3(3 of 4)-- e507003.cab
- disk4(4 of 4)-- e507004.cab

Step 2. Assign the Label name as follows using the properties of your computer's Windows Explorer as shown in Figure C-1.

- DISK_1 (for disk1)
- DISK_2 (for disk2)
- DISK_3 (for disk3)
- DISK_4 (for disk4)

Figure C-1

Windows Explorer (example)

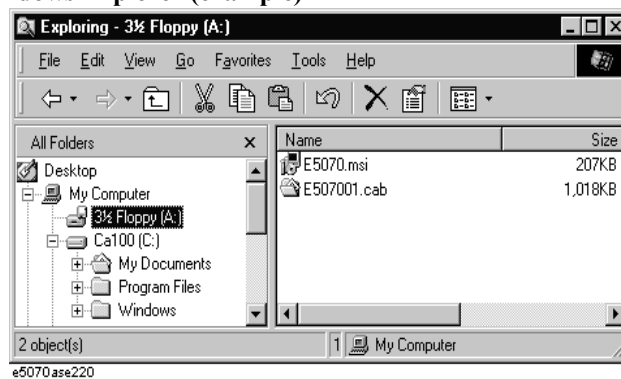

1. Insert the disk1(1 of 4) into the FDD of your computer.
2. On the Windows Explorer, click **3 1/2 Floppy [A:]** and confirm the files.
3. Right click on **3 1/2 Floppy [A:]**, then click **Properties**. The Properties dialog box appears.

4. Enter the Label name in the Label box of properties dialog box (General) for the disk1 as shown in Figure C-2, and press the **OK** button.

Figure C-2 Properties Dialog Box (example)

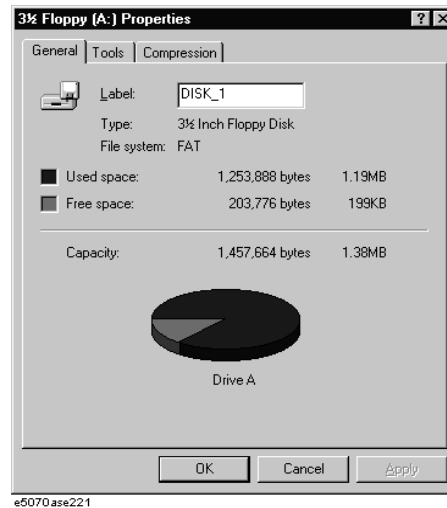

5. Perform 1 through 4 for each disk.

NOTE

If the label name is not assigned, the firmware update for the E5070A/E5071A will not be done correctly.

How to update the E5070A/E5071A firmware

It is possible to update the E5070A/E5071A firmware, but not the following software by this procedure.

- OS (Operating System)
- VBA (Visual Basic for Application)
- Calibration Constant Data

The following is the procedure to update the E5070A/E5071A firmware.

- Step 1.** Prepare the E5070A/E5071A firmware installation disks (four disks).
- Step 2.** Connect the mouse and the keyboard to the E5070A/E5071A rear panel. Then turn the E5070A/E5071A on.
- Step 3.** Exit from the E5070A/E5071A Measurement Display.
 1. Press **[System]** key.
 2. Press **Service Menu - Restart Menu** on the menu bar, and the Password dialog box will appear.
 3. Enter the password **e507xa** into the Password box.
 4. Press **Restart as Service** on the menu bar, and the instrument will be restarted.
- Step 4.** Double-click the “**My Computer**” icon on the Windows desktop.

Firmware Update Firmware Update

- Step 5.** Insert the E5070A/E5071A firmware installation disk1 (1 of 4) into the FDD of the E5070A/E5071A.
- Step 6.** Double-Click the “3 1/2 Floppy [A:]” icon.
- Step 7.** Remove the old version of the firmware using the following procedure.
1. Double-Click “**E5070.msi**” icon. The E5070A/E5071A Setup Wizard(uninstall) will start automatically as shown in Figure C-3.
 2. Click on the **Remove E5070A/E5071A** option button on the E5070A/E5071A Setup Wizard as shown in Figure C-3, then click on the **Finish** button.

Figure C-3

E5070A/E5071A Setup Wizard (uninstall)

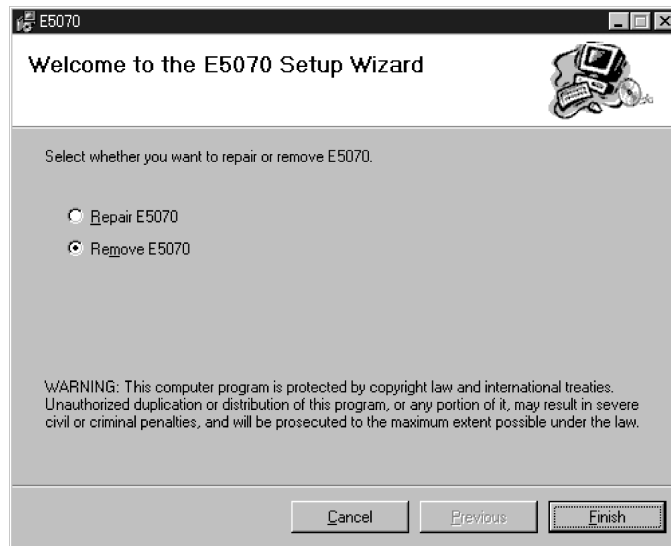

- Step 8.** Install the new version of the firmware using the following procedure.
1. Double-Click “**E5070.msi**” icon. The E5070A/E5071A Setup Wizard will start automatically as shown in Figure C-4.
 2. Click on the **Next** to continue the firmware installation on the E5070A/E5071A Setup Wizard as shown in Figure C-4.
 3. After the disk1 installation is finished, insert the firmware installation disk2 (2 of 4) into the FDD of the E5070A/E5071A, then click **OK**.
 4. After the disk2 installation is finished, insert the firmware installation disk3 (3 of 4) into the FDD of the E5070A/E5071A, then click **OK**
 5. After the disk3 installation is finished, insert the firmware installation disk4 (4 of 4) into the FDD of the E5070A/E5071A, then click **OK**

Figure C-4 E5070A/E5071A Setup Wizard

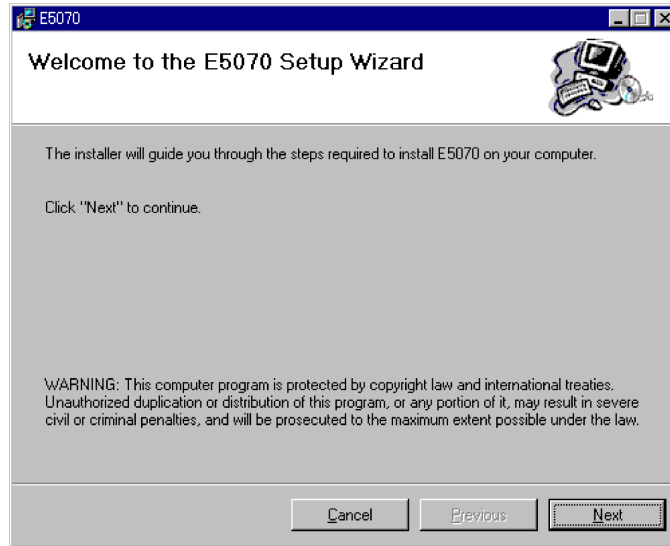

Step 9. Double-click “**Restart as instr**” icon on the Windows desktop, and the instrument will be restarted and the measurement screen will appear.

Firmware Update
Firmware Update

D **Computer Virus Check**

This appendix describes an example of how to check the system of E5070A/E5071A for computer viruses using computer viruses check software.

Computer Virus Check

The E5070A/E5071A should be protected against computer viruses. If you need to check the system of E5070A/E5071A for computer viruses, it's recommended that an external PC installed anti-virus software is used to access E5070A/E5071A's built-in drive (C and D) via LAN and perform virus scan.

The E5070A/E5071A has no virus function nor anti-virus software installed. The Windows operating system installed in this instrument is customized for more effective operation. Installing Windows-based software (including anti-virus software) for ordinary PCs into this instrument may affect the behavior of the instrument during measurement.

Required equipment

- E5070A or E5071A (with keyboard and mouse).
- An external PC installed anti-virus software such as "Norton AntiVirus®".
- A crossed LAN cable (It enables the peer-to-peer communication between the E5070A/E5071A and the PC.)

How to check the drive C and D of E5070A/E5071A

The following is an example procedure to check the drive C and D of E5070A/E5071A using the external PC.

Step 1. Enable the network connection function of the E5070A/E5071A. If the function has been enabled, skip this step.

1. Press **System** key.
2. Press **Misc Setup** (for firmware rev 2.0 and above) - **Network Setup** , and press **Network Device** to **ENABLE**.
3. A dialog box will appear, press the **OK** to reboot the instrument.

Step 2. Set up the E5070A/E5071A for file sharing.

1. Press **System** key.
2. Press **Misc Setup - Network Setup - Network Configuration**.
3. The Network dialog box as shown in Figure D-1 will appear. In the **Configuration** tab, select **TCP/IP** (display it in reverse video) and press the **Properties** button.

Figure D-1 Network Dialog Box (“Configuration” Tab)

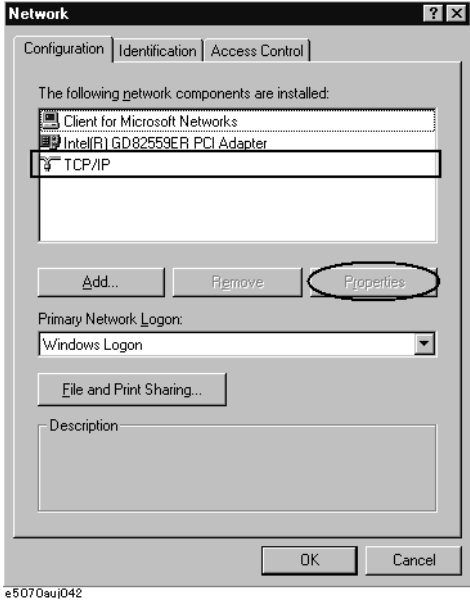

4. The dialog box in Figure D-2 appears.

If **Obtain an IP address automatically** has been selected, you select **Specify an IP address** and enter the IP address 192.168.0.1 and subnet mask 255.255.0.0 as shown in Figure D-2. Press the **OK** button.

If a specific IP address and subnet mask have been assigned, press the **OK** button.

Figure D-2 Network Dialog Box (“IP Address” Tab)

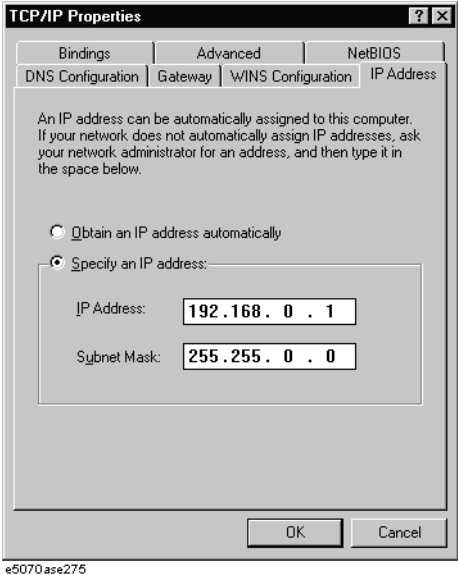

5. In the Network dialog box, select **Identification** tab. Confirm that the computer name is **E507X** as shown in Figure D-3.

Figure D-3 Network Dialog Box (“Identification” Tab)

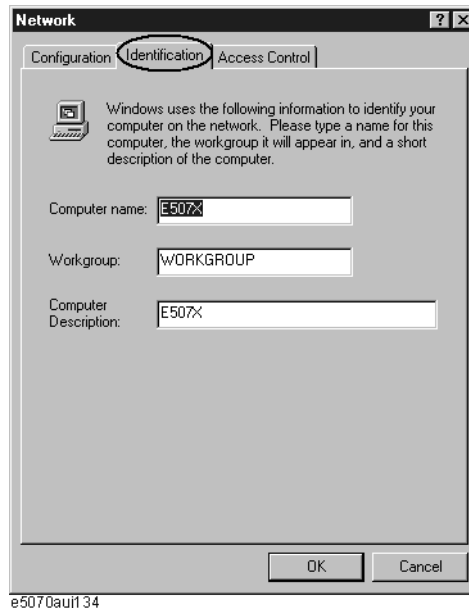

6. In the Network dialog box, select **Configuration** tab. Click the **File and Print Sharing...** button as shown in Figure D-4 for the drive D of the E5070A/E5071A. If File and Print Sharing has been set, proceed Step 3.

Figure D-4 Network Dialog Box (“Configuration”)



7. The File and Print Sharing dialog box as shown in Figure D-5 appears. Check **I want to be able to give others access to my files** and click the **OK** button.

Figure D-5 File and Print Sharing dialog box

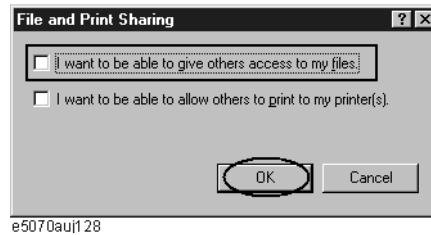

8. Click the **OK** button in the Network dialog box (see Figure D-4).
9. The System Setting Change dialog box as shown in Figure D-6 appears. Click the **Yes** button to restart.

Figure D-6 System Settings Change dialog box

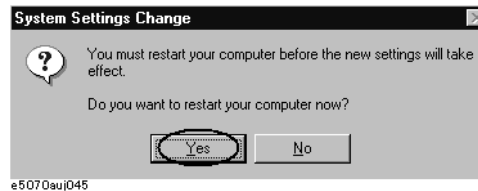

Step 3. Share the C drive of E5070A/E5071A.

1. Press **System** key.
2. Click **Service Menu - Restart Menu** on the menu bar, and the Password dialog box will be open.
3. Enter the password **e507xa** into the Password box.
4. Click **Restart as Service** on the menu bar, and the instrument will be restarted.
5. Double-click "**My Computer**" icon on Windows desktop. Right click on **[C:]**, and then click **Sharing**. The Sharing dialog box will be displayed.
6. Mark the **Shared As** and the **Read-Only** as shown in Figure D-7. Press the **OK** button.

Figure D-7 Properties (Sharing) Dialog Box

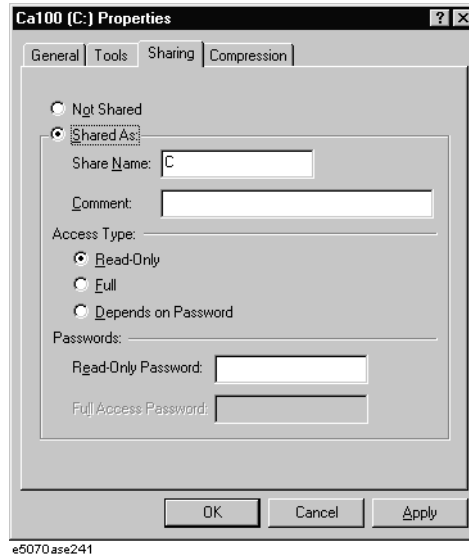

Step 4. Connect the E5070A/E5071A to the PC using the crossed LAN cable.

Step 5. Set up the external PC's IP address and subnet mask.

1. Double-click "**My Computer**" icon on Windows desktop of the external PC. And double-click **Control Panel**. The Control Panel window will appear.
2. In the Control Panel window, double-click **Network**. The Network dialog box shown in fig will appear. In the **Configuration** tab, select **TCP/IP** (display it in revers video) and press the **Properties** button.
3. The dialog box appears. Select **Specify an IP address** and enter the IP address xxx.xxx.xxx.y and subnet mask xxx.xxx.xxx.xxx as shown in Figure D-8. The letters x represent the IP address and subnet mask of the E5070A/E5071A. The letter y is different from the IP address of the E5070A/E5071A. Press the **OK** button.

Figure D-8 Network Dialog Box (“IP Address” Tab)

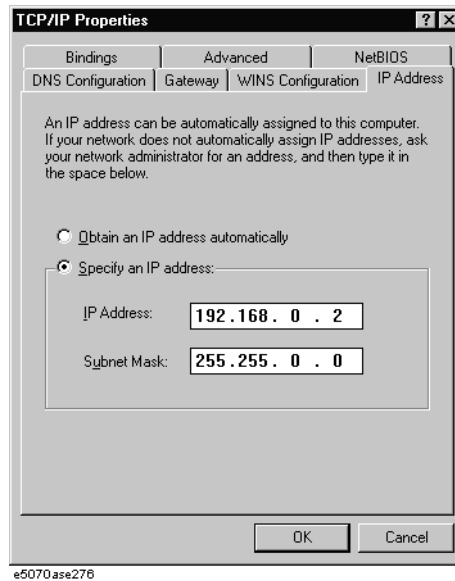

Step 6. Connect the drive of E5070A/E5071A to the PC, and check the drive using anti-virus software.

1. Click **Programs -Window Explorer** on the Start Menu to start up the PC’s Explorer. Click **Tools - Map Network Drive** on the menu of the Explorer.
2. Select a suitable drive name, enter the network path as shown in Figure D-9, and then press the **OK** button. For example, the network path `\\e507x\c` is for drive C, `\\e507x\user$` is for the drive D.

Figure D-9 Map Network Drive Dialog Box

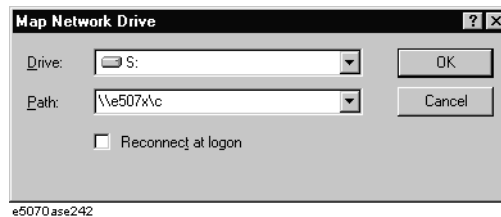

When drive D is selected, the Enter Network Password dialog box will appear. Enter the password `e507xa` and press the **OK** button.

3. The network path will appear on the PC’s Explorer. Confirm that the network path you enter is connected to the PC.
4. Execute the anti-virus software on the PC, and the menu for the anti-virus software will appear. Check the drive you entered on 2 of Step 4. For the operation of anti-virus software, refer to its manual.
5. Check if the drives C and D are infected.

Step 7. Disconnect the drives of E5070A/E5071A from the PC.

1. Click **Programs -Window Explorer** on the Start Menu to start up the PC’s Explorer.

Computer Virus Check Computer Virus Check

Click **Tools - Disconnect Network Drive** on the menu of the Explorer. Disconnect Network dialog box will appear.

2. Select Network Drive you checked, and press the **OK** button. The drive will disappear from the Explorer.

NOTE

If no drive has been infected, proceed the next step.

If the drive C or D has been infected, replace the A27 mass storage of the E5070A/E5071A.

Step 8. Disable the C drive of E5070A/E5071A.

1. Double-click “**My Computer**” icon on Windows desktop of the E5070A/E5071A. Right click on [C:], and then click **Sharing**. The Sharing dialog box will appear.
2. Mark the **Not Shared** as shown in Figure D-10. Press the **OK** button.

Figure D-10

Properties (Sharing) Dialog Box

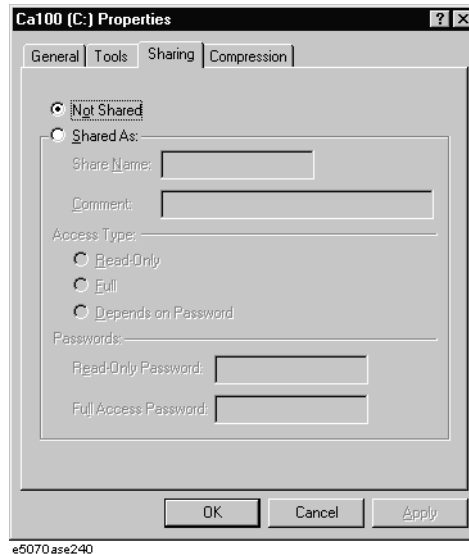

Step 9. Restart the measurement screen of the E5070A/E5071A.

1. Double-click “**Restart as instr**” icon on the Windows desktop of the E5070A/E5071A, and the instrument will be restated and the measurement screen will appear.

Step 10. Change the IP address and subnet mask of the E5070A/E5071A if you selected **Specify an IP address** on the 4 of Step 2.

1. Press **System** key.
2. Press **Misc Setup - Network Setup - Network Configuration**.
3. The Network dialog box as shown in Figure D-11 will appear. In the **Configuration** tab, select **TCP/IP** (display it in reverse video) and press the **Properties** button.

Figure D-11 Network Dialog Box (“Configuration” Tab)

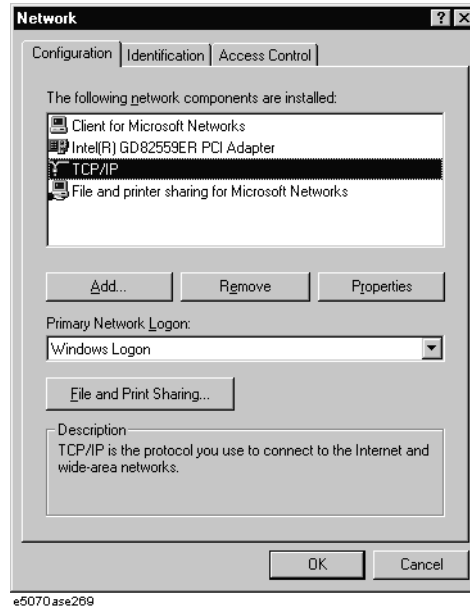

4. The dialog box in fig appears. Select **Obtain an IP address automatically** and press the **OK** button.

Figure D-12 Network Dialog Box (“IP Address” Tab)

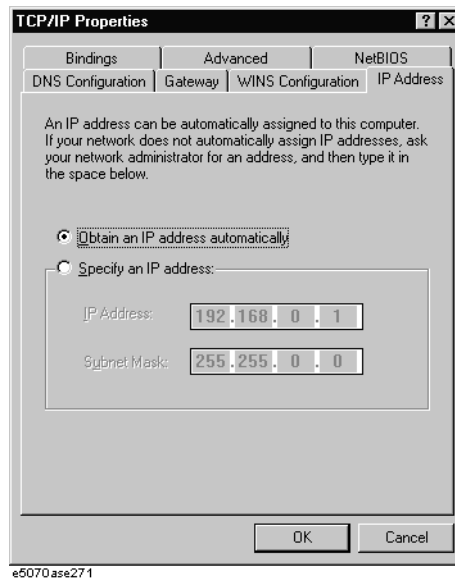

- Step 11. Remove **File and printers sharing for Microsoft Networks** if you set **File and Print Sharing** on the 6 of Step 2.
 1. In the **Configuration** tab, select **File and printers sharing for Microsoft Networks** and press the **Remove** button. Press the **OK** button.

Figure D-13 Network Dialog Box (“Configuration” Tab)

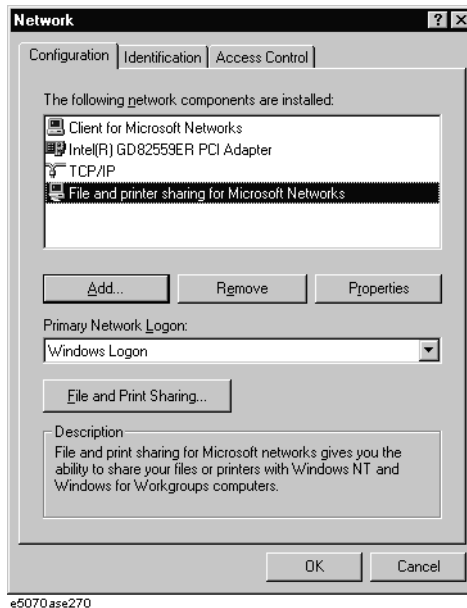

2. The System Setting Change dialog box appears. Press the **Yes** button to restart.

Step 12. Disable the network connection function of the E5070A/E5071A if you enabled the network connection function on Step 1.

1. Press **System** key.
2. Press **Misc Setup - Network Setup** , and press **Network Device** to **DISABLE**.
3. A dialog box will appear, press the **OK** to reboot the instrument.

E **Power Requirement**

Preparation for Power Supply

Before turning on power to the equipment, be sure to verify the following:

Power Requirements

The E5070A/E5071A requires the following power source:

	Requirements
Voltage	90 to 132 VAC or 198 to 264 VAC *1
Frequency	47 to 63 Hz
Maximum power consumption	350 VA

*1. Switched automatically by the E5070A/E5071A in conformity to the voltage.

Power Cable



In accordance with international safety standards, this instrument is equipped with a three-wire power cable. When connected to an appropriate ac power outlet, this cable grounds the instrument frame. The type of power cable shipped with each instrument depends on country of destination. Refer to Figure E-1 for the part numbers of the power cables available.

WARNING

For protection from electrical shock, the power cable ground must not be defeated.

The power plug must be plugged into an outlet that provides a protective earth ground connection.

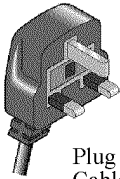
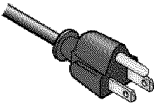
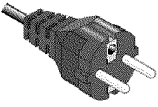
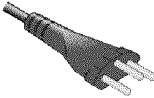

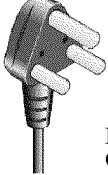
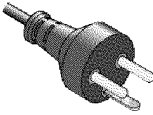
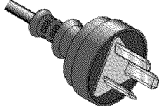
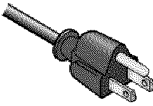
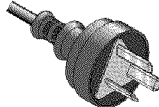
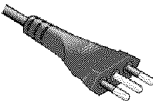
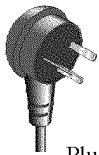
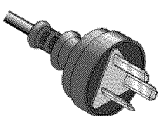
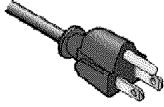

Figure E-1 Power cable options

<p>OPTION 900</p>  <p>United Kingdom</p> <p>Plug : BS 1363/A, 250V, 10A Cable: 8120-1351</p>	<p>OPTION 903</p>  <p>U.S./ Canada</p> <p>Plug : NEMA 5-15P, 125V, 10A Cable: 8120-1378</p>
<p>OPTION 902</p>  <p>Continental Europe</p> <p>Plug : CEE 7 Standard Sheet VII, 250V, 10A Cable: 8120-1689</p>	<p>OPTION 906</p>  <p>Switzerland</p> <p>Plug : SEV Type 12, 250V, 10A Cable: 8120-2104</p>
<p>OPTION 904</p>  <p>U.S./ Canada</p> <p>Plug : NEMA 6-15P, 250V, 6A Cable: 8120-0698</p>	<p>OPTION 917</p>  <p>India/ Republic of S.Africa</p> <p>Plug : IEC 83-B1, 250V, 10A Cable: 8120-4211</p>
<p>OPTION 912</p>  <p>Denmark</p> <p>Plug : SR 107-2-D, 250V, 10A Cable: 8120-2956</p>	<p>OPTION 920</p>  <p>Argentina</p> <p>Plug : Argentine Resolution 63, Annex IV, 250V, 10A Cable: 8120-6870</p>
<p>OPTION 918</p>  <p>Japan</p> <p>Plug : JIS C 8303, 125V, 12A Cable: 8120-4753</p>	<p>OPTION 922</p>  <p>China</p> <p>Plug : GB 1002, 250V, 10A Cable: 8120-8376</p>
<p>OPTION 921</p>  <p>Chile</p> <p>Plug : CEI 23-16, 250V, 10A Cable: 8120-6978</p>	<p>OPTION 919</p>  <p>Israel</p> <p>Plug : Israel SI 32, 250V, 10A Cable: 8120-5182</p>
<p>OPTION 901</p>  <p>Australia/ New Zealand</p> <p>Plug : AS 3112, 250V, 10A Cable: 8120-1369</p>	<p>OPTION 927</p>  <p>Thailand</p> <p>Plug : NEMA 5-15P, 250V, 10A Cable: 8120-8871</p>
<p>NOTE: Each option number includes a 'family' of cords and connectors of various materials and plug body configurations (straight, 90° etc.).</p>	



Turning the Power ON and OFF

Perform the following steps to turn the power ON or OFF.

Turning the power ON

- Step 1.** If the standby switch () in the lower-left part of the front panel is in the pressed down () position, press the switch to the popped up position ().
- Step 2.** Press the standby switch to the pressed down position ().
This operation turns ON the power, and the E5070A/E5071A starts the self-test.
- Step 3.** Confirm that the self-test indicates normal operation.
Normal operation is confirmed by the self-test if no error message appears.

Turning the power OFF

- Step 1.** Use either of the following methods to turn OFF the E5070A/E5071A.
- Press the standby switch () in the lower-left part of the front panel (now in the pressed down () position) to the popped up () position.
 - Send the shutdown command from an external controller.

These operations will start the E5070A/E5071A shutdown process (required software and hardware processes for turning the power off), and the power will turn OFF after a few seconds.

NOTE

Under normal circumstances, always press the standby switch (), or send the shutdown command from the external controller, to actuate the E5070A/E5071A shutdown process. **Never cut off the power supply directly by disconnecting the power cable plug from the rear panel of the unit.**

If the power supply is cut off directly by disconnecting the power cable plug or by disconnecting the power supply to the AC outlet, the shutdown process will not be carried out, and there is a risk of damage to the software or hardware of the E5070A/E5071A.

F Messages

The E5070A/5071A can display error messages as well as messages that indicate the internal operating status of the equipment. This appendix explains what these messages mean by listing them in alphabetical order.

Messages showing the status of the E5070A/5071A are displayed in the lower-left area of the E5070A/5071A LCD screen. These messages include error messages that occur during

Messages

the execution of GPIB commands and others that indicate the internal status of the equipment.

Error messages are indicated following the character string “[Err]” and can be read out by a GPIB command. Other kinds of messages are indicated without the “[Err]” character string and cannot be read out by a GPIB command. This section explains the meaning of each message and how to resolve the problem it indicates.

Error Messages

An error message is displayed against a red background in the instrument message/warning area in the lower left part of the screen. Pushing a front panel key or executing :DISP:CCL command clears the error message. Errors caused by the operation of a front panel key simply appear on the display. They are not stored in the error queue with some exceptions.

An error with a positive error number is one uniquely defined for this instrument. On the other hand, an error with a negative error number is basically one defined for common GPIB devices in IEEE488.2

A

20

Additional standard needed

The GPIB command that turns ON the calibration function has been sent before all of the data measurements needed to calculate the calibration factor have been completed. For instance, the “SENS:CORR:COLL:SAVE” command is sent to calculate calibration coefficients and turn on error correction for 1-Port Calibration when open and short calibration are completed but load calibration is not completed. Be sure to measure all necessary calibration data before sending commands. This error is not generated by front key operations.

B

-168

Block data not allowed

An block-data element has been received at a position where this instrument does not accept one.

C

240

Calibration data lost

This error occurs when a file containing the system calibration data is not found or in a damaged state at time of the startup of this instrument, indicating a failure of this instrument. Contact an Agilent Technology sales office or the company from which you bought the instrument.

22

Calibration method not selected

This error occurs when the command for validating the calibration, SENS:CORR:COLL:SAVE, is executed before the command for selecting a calibration type, SENS:CORR:COLL:METH:xxxx, is executed. This error is not generated by front key operations.

-148

Character data not allowed

A character data element (not violating the standard) has been received at a position where this instrument does not accept one. Double quotes (“) are omitted where it is necessary to place a parameter in double quotes (“), for example.

- 100 **Command error**
- A comprehensive syntax error has occurred showing that this instrument cannot detect a more detailed error. This code simply shows that a command error defined in 11.5.1.1.4, IEEE488.2 has occurred.
- 60 **Cont switching may damage source attenuator**
- This error occurs when different source attenuator (power range) settings are present during measurement on two or more channels. Performing such measurement for a long time is not recommended because of the possibility of the source attenuator being damaged. The measurement value is normal. This error occurs only on models with the extended power output (Option 214, 314, and 414).
- D**
- 222 **Data out of range**
- A data element (not violating the standard) outside the range defined by this instrument has been received. This error occurs when an integer-based command for which the parameter can be rounded exceeds the range of -65536 to +65536 or when a real-number-based command for which the parameter can be rounded exceeds the range of -9.9e37 to +9.9e37, for example.
- This error occurs also when a numeric value other than a specified one is entered into a command in which the “port number” and “CalKit number” are specified as parameters and hence the parameters are not rounded. Such commands are, for example, CALC:FSIM:BAL:TOP:BBAL:PPOR, SENS:CORR:COLL:ACQ:OPEN, SENS:CORR:COLL:ECAL:SOLT3, SENS:CORR:COLL:CKIT:ORD:LOAD, etc.
- 104 **Data type error**
- The parser has recognized a data element that must not exist. Block data has been sent instead of numeric value data or character string data that had been expected, for example.
- E**
- 32 **Ecal module not in appropriate RF path**
- This error occurs when an ECal command, SENS:CORR:COLL:ECAL:SOLTn, is executed with the port on the ECal module not connected correctly to the instrument.
- 200 **Execution error**
- An error associated with execution has been generated for which this instrument cannot specify the error message. This code shows that an error associated with execution defined in 11.5.1.1.5, IEEE488.2 has occurred. This error occurs also when a calibration measurement is aborted.
- 123 **Exponent too large**
- The absolute value of the exponent exceeds 32,000 (see 7.7.2.4.1, IEEE488.2).
- 178 **Expression data not allowed**
- An expression-data element has been received at a position where this instrument does not accept one.

- 170 **Expression error**
When the expression data is put to syntactic analysis, an error not corresponding to one of Error Numbers -171 through -179 occurs.
- F**
- 31 **Failed to configure ECal module**
This error occurs when the control of the ECal module fails at time of executing an ECal command, SENS:CORR:COLL:ECAL:SOLTn. The failure results from the failure to connect the ECal module to the USB port, failure of the ECal module, etc.
- 102 **Failed to copy file**
This error occurs when copying a file (MMEM:COPY command) fails.
- 104 **Failed to create directory**
This error occurs when creating a directory (MMEM:MDIR command) fails.
- 103 **Failed to delete file**
This error occurs when deleting a file (MMEM:DEL command) fails.
- 100 **Failed to read file**
This error occurs when a 2-port touchstone file (CALC:FSIM:SEND:PMC:PORT:USER:FILE command), the formatted data array (MMEM:LOAD:FDAT command) and limit table (MMEM:STOR:LIM command) for the active trace on the active channel, segment sweep table (MMEM:LOAD:SEGM command) for the active channel, a VBA project file (MMEM:LOAD:PROG command), etc. cannot be read normally.
- 101 **Failed to write file**
This error occurs when the formatted data array (MMEM:STOR:FDAT command) and limit table (MMEM:STOR:LIM command) for the active trace on the active channel, segment sweep table (MMEM:STOR:SEGM command) for the active channel, display image (MMEM:STOR:IMAG command) for the LCD screen, a VBA project file (MMEM:STOR:PROG command), etc. cannot be written normally.
- 257 **File name error**
A file name error. This message appears when an error exists in the file name and hence a command is not executed correctly. This error occurs when you try to copy to an unsuitable file name, for example.
- 256 **File name not found**
The file name specified is not found and hence the command is not executed correctly. This error occurs when you try to read a file that does not exist in a disk or a disk is not correctly inserted into the drive to read or write a file, for example.
- 107 **File transfer failed**
This error occurs when writing data into or reading data from a file (MMEM:TRAN command) fails.

G

-105 **GET not allowed**

A group execution trigger (GET) has been received in the program message (see 7.7, IEEE488.2).

H

-114 **Header suffix out of range**

The unit of the header is outside the range. The header is invalid in the unit for numeric parameters following a SCPI command.

I

53 **Log sweep requires 2 octave minimum span**

The span of sweep range is not satisfied the requirement for logarithmic sweep. The sweep type is automatically changed to linear sweep when this error occurs.

For example, this error occurs when, with the start and stop frequency are set 1 MHz and 2 MHz respectively, the sweep type is changed to logarithmic sweep.

Set the stop frequency to more than four times as many as the start frequency. And then select logarithmic sweep.

-224 **Illegal parameter value**

The parameter value is not suitable. This error occurs when the CALC:PAR:DEF command is used to specify an S-parameter that does not exist in the model (S44 in the case of a 2-port model), for example.

-282 **Illegal program name**

This error occurs when a nonexistent VBA program name is specified by the PROG:SEL:NAME command.

-213 **Init ignored**

Because another measurement is in progress, the request for initiating a measurement ("INIT" command) is ignored.

-161 **Invalid block data**

Block data has been expected, but the block data that appears is invalid for some reason (see 7.7.6.2, IEEE488.2). The END message is received before the length of block data has been filled, for example.

-101 **Invalid character**

An invalid character exists in the program message character string.

-141 **Invalid character data**

An invalid character is found in the character data element, or the parameter received is not valid.

-121 **Invalid character in number**
A character that is invalid for the data type subject to syntactic analysis has been received. For example, a letter is found in a decimal numeric value or a numeric character “9” in octal data.

-171 **Invalid expression**
The expression-data element is invalid (see 7.7.7.2, IEEE488.2). Parentheses are not paired, or illegal characters are used, for example.

-103 **Invalid separator**
The parser (a syntactic analysis program) had been expecting a delimiter, but a character that is not a delimiter has been sent.

-151 **Invalid string data**
Character string data has been expected, but the character string data that appears is invalid for some reason (see 7.7.5.2, IEEE488.2). The END message is received before the ending quotation mark character appears, for example.

-131 **Invalid suffix**
The suffix does not comply with the syntax defined in 7.7.3.2, IEEE488.2. Or it does not suit E5070A/5071A.

L

53 **Log sweep requires 2 octave minimum span**
The span of sweep range is not satisfied the requirement for logarithmic sweep. The sweep type is automatically changed to linear sweep when this error occurs.
For example, this error occurs when, with the start and stop frequency are set 1 MHz and 2 MHz respectively, the sweep type is changed to logarithmic sweep.
Set the stop frequency to more than four times as many as the start frequency. And then select logarithmic sweep.

M

-109 **Missing parameter**
The number of parameters is less than that required for the command, or the parameter has not been entered. For example, the command SENS {1 - 6} :SWE:POIN requires one more parameter.
Therefore, when a message “SENS1:SWE:POIN” is sent to a correct program message “SENS1:SWE:POIN 201” this instrument receives the former message as an invalid one because all parameters have not been entered. Enter command parameters correctly.

N

-120 **Numeric data error**
An error resulting from the numeric value data (including numeric value data having no decimal point representation) has occurred. A numeric value error other than Errors -121 through -129 has occurred.

Messages
Numeric data not allowed

- 128 **Numeric data not allowed**
An numeric-value-data element (not violating the standard) has been received at a position where this instrument does not accept one.
- O**
- 200 **Option not installed**
The command received has been ignored because of the mismatch between the contents of an option for this instrument and the command.
For example, this error occurs when the source attenuator (power range) is set at a value other than zero (SOUR:POW:ATT command) in a model not having the extended power output option.
This error is not generated by front key operations.
- 225 **Out of memory**
Insufficient memory is available in this instrument to perform the required operation.
- P**
- 220 **Parameter error**
When a parameter-related error other than Errors -221 through -229 occurs, that error is displayed.
- 108 **Parameter not allowed**
The number of parameters exceeds that required for the command.
For instance, when a program message “:SENS1:SWE:TYPE LIN, SEGM” is sent instead of a correct program message with a command “:SENS1:SWE:TYPE LIN” which requires a parameter, the instrument receives the message as the number of parameters is invalid. See the command reference to confirm the required number of parameters.
- 41 **Peak not found**
This error occurs when, after specifying a peak and executing the CALC:MARK:FUNC:EXEC and CALC:FUNC:EXEC commands, the specified peak is not found in the marker search analysis.
- 220 **Phase lock loop unlocked**
This error occurs when the PLL circuit of this instrument becomes unlocked while the measurement is in progress. The measurement value is not correct. This error may occur when an external reference out of specification is connected to this instrument. Should an error occur with an external reference not connected, this instrument is faulty. Contact an Agilent Technology sales office or the company from which you bought the instrument.
- 221 **Port 1 receiver overload**
The input to Test Port 1 exceeds the maximum input level. The measurement value is not correct. When a DUT is an amplifier or the like, this error may occur, damaging the receiver in the worst case. Should this error occur with a passive part used as the DUT or with nothing connected to the test port, this instrument is faulty. Contact an Agilent Technology sales office or the company from which you bought the instrument.

- 222 **Port 2 receiver overload**
The input to Test Port 2 exceeds the maximum input level. The measurement value is not correct. When a DUT is an amplifier or the like, this error may occur, damaging the receiver in the worst case. Should this error occur with a passive part used as the DUT or with nothing connected to the test port, this instrument is faulty. Contact an Agilent Technology sales office or the company from which you bought the instrument.
- 223 **Port 3 receiver overload (for Options 313, 314, 413, and 414 only)**
The input to Test Port 3 exceeds the maximum input level. The measurement value is not correct. When a DUT is an amplifier or the like, this error may occur, damaging the receiver in the worst case. Should this error occur with a passive part used as the DUT or with nothing connected to the test port, this instrument is faulty. Contact an Agilent Technology sales office or the company from which you bought the instrument.
- 224 **Port 4 receiver overload (For Options 413 and 414 only)**
The input to Test Port 4 exceeds the maximum input level. The measurement value is not correct. When a DUT is an amplifier or the like, this error may occur, damaging the receiver in the worst case. Should this error occur with a passive part used as the DUT or with nothing connected to the test port, this instrument is faulty. Contact an Agilent Technology sales office or the company from which you bought the instrument.
- 241 **Power on test failed**
This error occurs when the power-on test fails, indicating a failure of this instrument. Contact an Agilent Technology sales office or the company from which you bought the instrument.
- 120 **Printer error**
This error occurs when the previous printing is still in progress or the printer fails (offline, short of paper, etc.) at time of outputting the display image on the LCD screen to the printer (HCOP:IMM command).
- 121 **Print failed**
This error occurs when printing fails for reasons other than Error 120, Printer error.
- 284 **Program currently running**
This error occurs when the PROG:SEL:STAT RUN command is executed with the VBA program in the Run state.
- 112 **Program mnemonic too long**
The length of the header exceeds 12 characters (see 7.6.1.4.1, IEEE488.2).
- 286 **Program runtime error**
An error occurring when VBA is executed.
- Q**
- 430 **Query DEADLOCKED**
The state that generates a “DEADLOCKED” Query error (see 6.3.1.7, IEEE488.2). This error occurs when both input and output buffers have become full, preventing the instrument from continuing processing, for example.

Messages
Query error

- 400 **Query error**
A comprehensive query error has occurred showing that this instrument cannot detect a more detailed error. This code simply shows that a query error defined in 11.5.1.1.7 and 6.3, IEEE488.2 has occurred.
- 410 **Query INTERRUPTED**
The state that generates a “INTERRUPTED” Query error (see 6.3.2.3, IEEE488.1). This error occurs when data bytes (DAB) or GET are received before the transmission of the response after a query has not been completed, for example.
- 420 **Query UNTERMINATED**
The state that generates an “UNTERMINATED” Query error (see 6.3.2, IEEE488.2). This error occurs when this instrument is designated as the talker and an incomplete program message is received, for example.
- 440 **Query UNTERMINATED after indefinite response**
After a query asking for an indefinite response has been run, another query is received in the same program message (See 6.5.7.5.7, IEEE488.2).
- R**
- 105 **Recall failed**
This error occurs when reading an instrument status file (State01.sta, etc.) (MMEM:LOAD:STAT command) fails.
- S**
- 106 **Save failed**
This error occurs when writing an instrument status file (State01.sta, etc.) (MMEM:STOR:STAT command) fails.
- 50 **Specified channel hidden**
This error occurs when an attempt is made to activate a channel not on display using the DISP:WIND:ACT command. This error is not generated by front key operations.
- 21 **Specified ports overlapped**
This error occurs when a port number is duplicated in a command requiring two or more port numbers as parameters. Such commands are, for example, CALC:FSIM:BAL:TOP:SSB:PPOR 1,2,3,3. Specify port setup correctly to avoid duplication of ports. This error is not generated by front key operations.
- 150 **String data error**
When a character-string-data element is put to syntactic analysis, an error not corresponding to one of Error Numbers -151 through -159 occurs.
- 158 **String data not allowed**
A character-string-data element has been received at a position where this instrument does not accept one.

- 138 **Suffix not allowed**
A suffix is attached to a numeric value element to which a suffix is not allowed to be attached.
- 134 **Suffix too long**
The unit is too long.
The unit is expressed in 12 or more characters (see 7.7.3.4, IEEE488.2).
- 102 **Syntax error**
A command or data type that is not recognized exists.
- 310 **System error**
One of the errors designated as “system errors” in this instrument has occurred.
- T**
- 40 **Target value not found**
This error occurs when the target is not found during the marker search analysis after specifying the target and executing the CALC:MARK:FUNC:EXEC and CALC:FUNC:EXEC commands. This error occurs also when the bandwidth is not found after executing the bandwidth marker command, CALC:MARK:BWID:DATA?
- 124 **Too many digits**
The number of digits of the argument of the decimal numeric-value-data element exceeds 255 with the preceding 0 removed (see 7.7.2.4.1, IEEE488.2).
- 223 **Too much data**
The block-, expression-, or character-string-type program data that has been received conforms with the standard. But it exceeds the amount that can be processed under the condition of the memory or conditions specific to memory-related devices. In this instrument, this error occurs when the number of characters exceeds 254 in a character-string parameter.
- 54 **Transform, Gate not allowed**
This error occurs when number of points is set 2 or sweep type is set logarithmic/segment sweep, the gating or transform function of time domain function is turned on.
Set number of points to more than 3, the sweep type to linear sweep. And then, turn on the gating or transform function of time domain function.
- 211 **Trigger ignored**
This instrument receives and detects a trigger command (“TRIG”) or an external trigger signal. But it is ignored due to the timing condition (This instrument is not in the wait-for-trigger state, for example). Change the setup so that a trigger command or an external trigger signal can be sent after the instrument has entered the wait-for- trigger state.

U

-113

Undefined header

A command not defined in this instrument, though not illegal in the syntactic structure, has been received. For example, when a message “:DISP:WIND1:TABL:MEM ON” is sent to a correct program message “:DISP:WIND1:TRAC1:MEM ON,” the message sent is received as an undefined command by this instrument. See the command reference and use correct commands.

This error occurs also when a port not existing on this model is specified in a command specifying a port number as an index. Such commands are CALC:FSIM:SEND:DEEM:PORTn:xxxx, CALC:FSIM:SEND:PMC:PORTn:xxxx, CALC:FSIM:SEND:ZCON:PORTn:Z0:R, and SENS:CORR:EXT:PORTn:TIME; they include PORTn as a part.

V

30

Valid Ecal module not found

This error occurs when the number of ports of the ECal module connected is less than the necessary number of ports. This error occurs, for example, when a 4-port Cal executing command, SENS:CORR:COLL:ECAL:SOLT4, is executed with a 2-port ECal module connected. This error is not generated by front key operations.

Warning Message

A warning message is displayed in the instrument message/Warning area in the lower left part of the display against a gray background. Pushing a front panel key or executing :DISP:CCL command clears the message.

This message simply appears on the display, being not known to a remote environment such as a GPIB. This message is not displayed when another error (against a red background) has already been displayed in the instrument message/Warning area.

The warning messages for this instrument are as follows:

Peak not found

This warning message is displayed when, with the tracking turned on, the peak specified by the marker search has not been found by the time the sweep is finished (with the tracking executed).

Segment table changed

This warning message is displayed when the setting specified segment by segment in the segment table is automatically changed by a change in the other setting.

For example, this warning message is displayed when, with the power specified segment by segment in the segment table, the power setting for a segment is adjusted by a change in the power range setting.

Target value not found

This warning message is displayed when, with the tracking turned on, the target specified by the marker search has not been found by the time the sweep is finished (with the tracking executed).

This warning message is displayed also when, with the bandwidth marker displayed, the setting for the bandwidth marker is changed at the end of the sweep, or when, with the active marker changed or moved, the bandwidth is not found.

Transform, Gate not allowed

This warning message is displayed when the gating/transform function of time domain function is turned on, number of points is set 2 or sweep type is set logarithmic/segment sweep.

The gating function and transform function are automatically turned off when this warning message is displayed.

Messages indicating the internal status of the equipment

Messages that indicate the internal status of the equipment include equipment irregularities as well as the results of processing (or current processing status). These messages do not have numbers.

Messages indicating measurement failure

DC bias overload

During application of DC bias voltage, a sudden change in the connection condition of the DUT has lowered the direct-current impedance, resulting in momentary over-current at the DC bias source.

Do not remove the DUT during application of DC bias. If this error occurs frequently during normal measurement, this may be due to instrument failure.

PLL Unlock

An error has been detected in the internal PLL (Phase Lock Loop) circuit of the E5070A/5071A. The PLL is used to generate a stable frequency source. This can occur due to an error of the external reference signal or when the power is turned ON in a low-temperature environment.

If the external reference signal has not been inputted or shows no error, instrument tuning or repair is necessary. If the message does not disappear in a few minutes after turning the power ON, instrument tuning or repair is necessary.

Power on test failed

An error has been detected during the self-test after turning on the power.

RF overload

There has been a ranging failure in the internal circuit due to a sudden change in impedance caused by removing the DUT or some other reason during measurement.

Do not remove the DUT during measurement. If this error occurs frequently during normal measurement, there may be instrument failure.

Messages indicating the results (or current status) of processing

Cal done

Calculation and storage of a calibration coefficient completed.

Cal measure aborted

Measurement of calibration data aborted.

Comp done

Calculation and storage of a fixture compensation coefficient completed.

Comp measure aborted

Measurement of a fixture compensation coefficient aborted.

Peak not found

Peak search function executed, but no defined peak was found.

Target value not found

Target search function executed, but no target measurement value was found.

Trigger hold

Measurement is in hold mode, in which a trigger is not accepted.

Wait -- measuring cal standard

Calibration data are now being measured.

Wait -- measuring comp standard

Fixture compensation data are now being measured.

Messages

Wait -- measuring comp standard

REGIONAL SALES AND SUPPORT OFFICES

For more information about Agilent Technologies test and measurement products, applications, services, and for a current sales office listing, visit our web site: <http://www.agilent.com/find/tmdir>. You can also contact one of the following centers and ask for a test and measurement sales representative. 11/29/99

United States:

Agilent Technologies
Test and Measurement Call Center
P.O.Box 4026
Englewood, CO 80155-4026
(tel) 1 800 452 4844

(fax) (61 3) 9272 0749
(tel) 0 800 738 378 (New Zealand)
(fax) (64 4) 802 6881

Canada:

Agilent Technologies Canada Inc.
5150 Spectrum Way
Mississauga, Ontario
L4W 5G1
(tel) 1 877 894 4414

Asia Pacific:

Agilent Technologies
24/F, Cityplaza One, 1111 King's Road,
Taikoo Shing, Hong Kong
(tel) (852)-3197-7777
(fax) (852)-2506-9284

Europe:

Agilent Technologies
Test & Measurement
European Marketing Organization
P.O.Box 999
1180 AZ Amstelveen
The Netherlands
(tel) (31 20) 547 9999

Japan:

Agilent Technologies Japan Ltd.
Call Center
9-1, Takakura-Cho, Hachioji-Shi,
Tokyo 192-8510, Japan
(tel) (81) 426 56 7832
(fax) (81) 426 56 7840

Latin America:

Agilent Technologies
Latin American Region Headquarters
5200 Blue Lagoon Drive, Suite #950
Miami, Florida 33126
U.S.A.
(tel) (305) 267 4245
(fax) (305) 267 4286

Australia/New Zealand:

Agilent Technologies Australia Pty Ltd
347 Burwood Highway
Forest Hill, Victoria 3131
(tel) 1-800 629 485 (Australia)